

RE 50 135/04.03

Replaces: 01.03

**Accumulator assembly
Type ABSBG**

H/A/D 6170/99

Accumulator assembly type ABSBG-...

Overview of contents**Contents**

	Page
Features	1
Ordering details	2
Symbols	2
Selection table	3
Accumulator assembly kits	4
Unit dimensions	5 to 7
Notes on commissioning, maintenance and operation	8
Engineering guidelines	8

Features

- Accumulator assembly with safety block to DIN 24 552
- Diaphragm or bladder type accumulators
- Safety block with integrated isolator valve, safety valve (design tested) and unloading valve
- Unloading valve optionally with manual or electrical operation
- Glycerine filled pressure gauge with red marking of the maximum relief pressure
- Weld-on brackets



© 2003
by Bosch Rexroth AG, Industrial Hydraulics, D-97813 Lohr am Main

All rights reserved. No part of this document may be reproduced or stored, processed, duplicated or circulated using electronic systems, in any form or by any means, without the prior written authorisation of Bosch Rexroth AG.
In the event of contravention of the above provisions, the contravening party is obliged to pay compensation.

Selection table (further variants on request)

With manually operated unloading valve

Accumulator type	Accumulator size in litres	Max. relief pressure PN in bar	Safety block DN	Designation	Material No.	Weight in kg
Bladder type accumulator	1.0	330	10	ABSBG-B1,0/SS10-U-330-M CM/C	R900713406	12
	2.5	330	10	ABSBG-B2,5/SS10-U-330-M CM/C	R900713407	19
	4.0	330	10	ABSBG-B4,0/SS10-U-330M CM/C	R900713408	21
	10	330	20	ABSBG-B10/SS20-U-330-M CM/C	R900713409	47
	20	330	20	ABSBG-B20/SS20-U-330-M CM/C	R900713410	71
	32	330	30	ABSBG-B32/SS30-U-330-M CM/C	R900713411	126
	50	330	30	ABSBG-B50/SS30-U-330-M CM/C	R900713412	157
Diaphragm type accumulator	0.6	330	10	ABSBG-M0,6/SS10-U-330-M CM/C	R900713413	10
	0.75	210	10	ABSBG-M0,75/SS10-U-210-M CM/C	R900713414	9
	1.4	140	10	ABSBG-M1,4/SS10-U-140-M CM/C	R900713415	10
	2.0	100	10	ABSBG-M2,0/SS10-U-100-M CM/C	R900713416	11

With electrically operated unloading valve

Accumulator type	Accumulator size in litres	Max. relief pressure PN in bar	Safety block DN	Designation	Material No.	Weight in kg
Bladder type accumulator	1.0	330	10	ABSBG-B1,0/SS10-U-330-EG24NK4CM/C	R900713425	13
	2.5	330	10	ABSBG-B2,5/SS10-U-330-EG24NK4CM/C	R900713426	19
	4.0	330	10	ABSBG-B4,0/SS10-U-330-EG24NK4CM/C	R900713427	22
	10	330	20	ABSBG-B10/SS20-U-330-EG24NK4CM/C	R900713428	47
	20	330	20	ABSBG-B20/SS20-U-330-EG24NK4CM/C	R900713429	71
	32	330	30	ABSBG-B32/SS30-U-330-EG24NK4CM/C	R900713431	126
	50	330	30	ABSBG-B50/SS30-U-330-EG24NK4CM/C	R900713432	157
Diaphragm type accumulator	0.6	330	10	ABSBG-M0,6/SS10-U-330-EG24NK4CM/C	R900713433	10
	0.75	210	10	ABSBG-M0,75/SS10-U-210-EG24NK4CM/C	R900713434	9
	1.4	140	10	ABSBG-M1,4/SS10-U-140-EG24NK4CM/C	R900713435	10
	2.0	100	10	ABSBG-M2,0/SS10-U-100-EG24NK4CM/C	R900713436	11

Accumulator assembly kits

Bladder-type accumulator (individual parts with material no.)

Kit ABSBG-...	Item	B1,0/SS10- U-330-..CM/C	B2,5/SS10- U-330-..CM/C	B4,0/SS10- U-330-..CM/C	B10/SS20- U-330-..CM/C	B20/SS20- U-330-..CM/C	B32/SS30- U-330-..CM/C	B50/SS30- U-330-..CM/C
Accumulator to AB-E 42-01	1	SB330-1,0	SB330-2,5	SB330-4,0	SB330-10	SB330-20	SB330-32	SB330-50
		R900746384	R900745892	R900746385	R900746177	R900745645	R900745893	R900746388
Safety block	2	ABZSS10	ABZSS10	ABZSS10	ABZSS20	ABZSS20	ABZSS30	ABZSS30
Manually operated		R900711164	R900711165	R900711165	R900711415	R900711415	R900713383	R900713383
Electrically operated		R900709606	R900709607	R900709607	R900709636	R900709636	R900709657	R900709657
Pressure gauge to AB-E 31-13/063-400	3	R900024096	R900024096	R900024096	R900024096	R900024096	R900024096	R900024096
Red marking		R900807807	R900807807	R900807807	R900807807	R900807807	R900807807	R900807807
Brackets ¹⁾ to AB-E 30-03		R900544109	R900544110	R900544111	R900544659	R900544660	R900544661	R900544661
Warning sign to RN175.06		R900751679	R900751679	R900751679	R900751679	R900751679	R900751679	R900751679

Diaphragm type accumulator (individual parts with material no.)

Kit ABSBG-...	Item	M0,6/SSB10- U-330-..CM	M0,75/SSB10- U-210-..CM	M1,4/SSB10- U-140-..CM	M2,0/SSB10- U-100-..CM
Accumulator to AB-E42-01	1	SBO330-0,6	SBO210-0,75	SBO140-1,4	SBO100-2,0
		R900746358	R900746360	R900746364	R900746367
Safety block	2	ABZSS10	ABZSS10	ABZSS10	ABZSS10
Manual		R900711167	R900711184	R900711138	R900711131
Electrical		R900709610	R900709596	R900709589	R900709586
Pressure gauge to AB-E 31-13/063-...	4	...-400	...-400	...-250	...-160
		R900024096	R900024096	R900024095	R900024094
Red marking		R900807807	R900807807	R900807807	R900807807
Brackets ¹⁾ to AB-E 30-03		R900145543	R900145543	R900145543	R900145542
Warning sign to RN175.06		R900751679	R900751679	R900751679	R900751679

¹⁾ Brackets suitable for bolting or welding on!

Unit dimensions (dimensions in mm)

Accumulator assembly with bladder type accumulator 1.0 to 2.5 litres

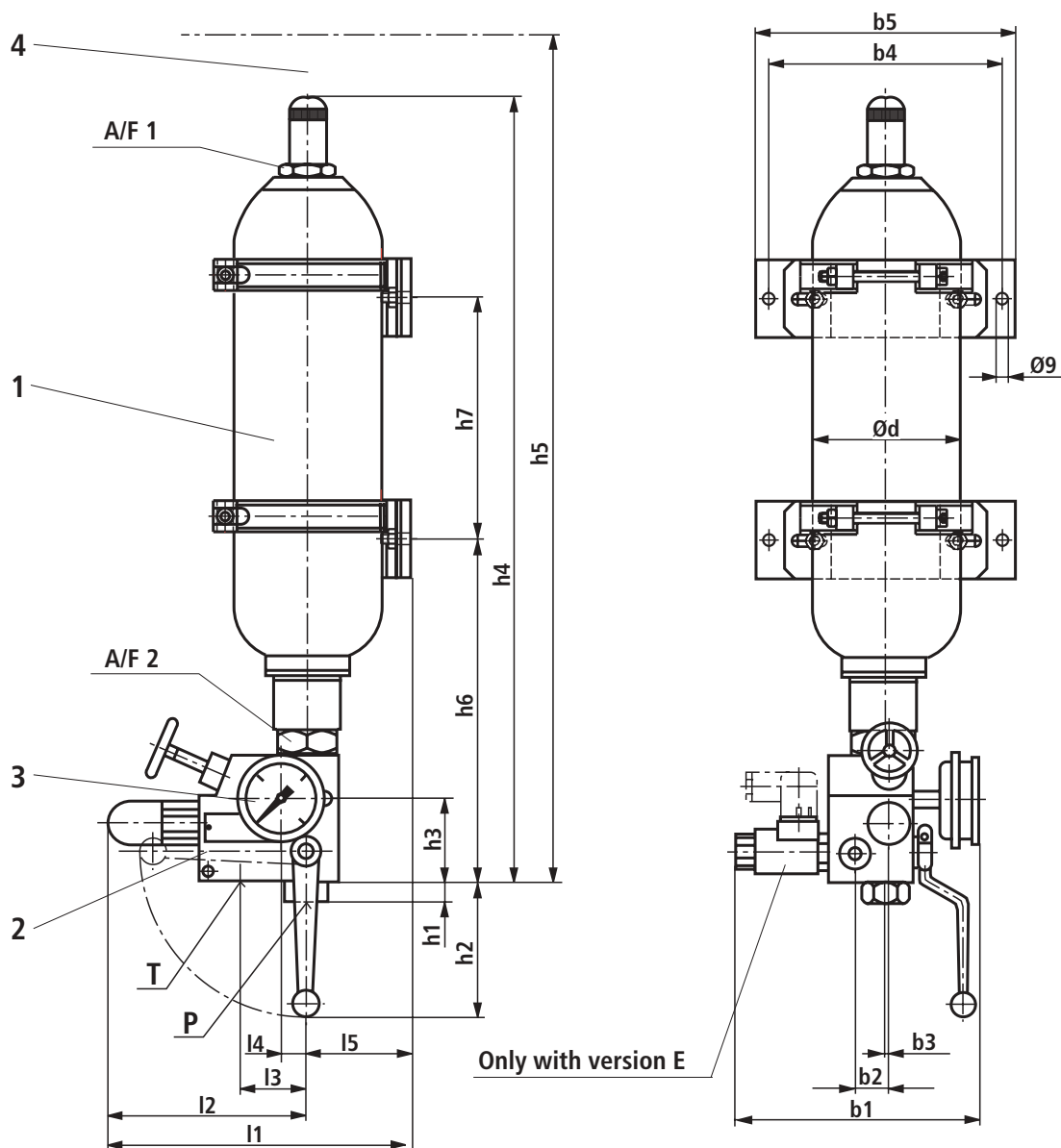

Kit ABSBG-...	Dimensions									
	b1	b2	b3	b4	b5	l1	l2	l3	l4	l5
B1,0/SS10-...	205	24	2	180	200	240	157	50	20	83
B2,5/SS10-...										

Kit ABSBG-...	Dimensions													
	h1	h2	h3	h4	h5	h6	h7	d	A/F1	A/F2	M1; M2	P	T	
B1,0/SS10-...	16	107	65	420	590	260	—	118	32	36	G 1/4	G 1/2	G 3/8	
B2,5/SS10-...				657	827		240		50					

- 1 Hydraulic accumulator
- 2 Safety block with:
 - System isolator valve
 - Pressure relief valve (design tested)
 - Manual unloading
 - Electro-magnetic unloading (version E)
- 3 Pressure gauge with red marking of max. relief pressure
- 4 Space required for testing and charging kit

Port designations:

- M1; M2 – Measuring port
- P – Pump port
- T – Tank port

Unit dimensions (dimensions in mm)

Accumulator assembly with bladder type accumulator 4.4 to 50 litres

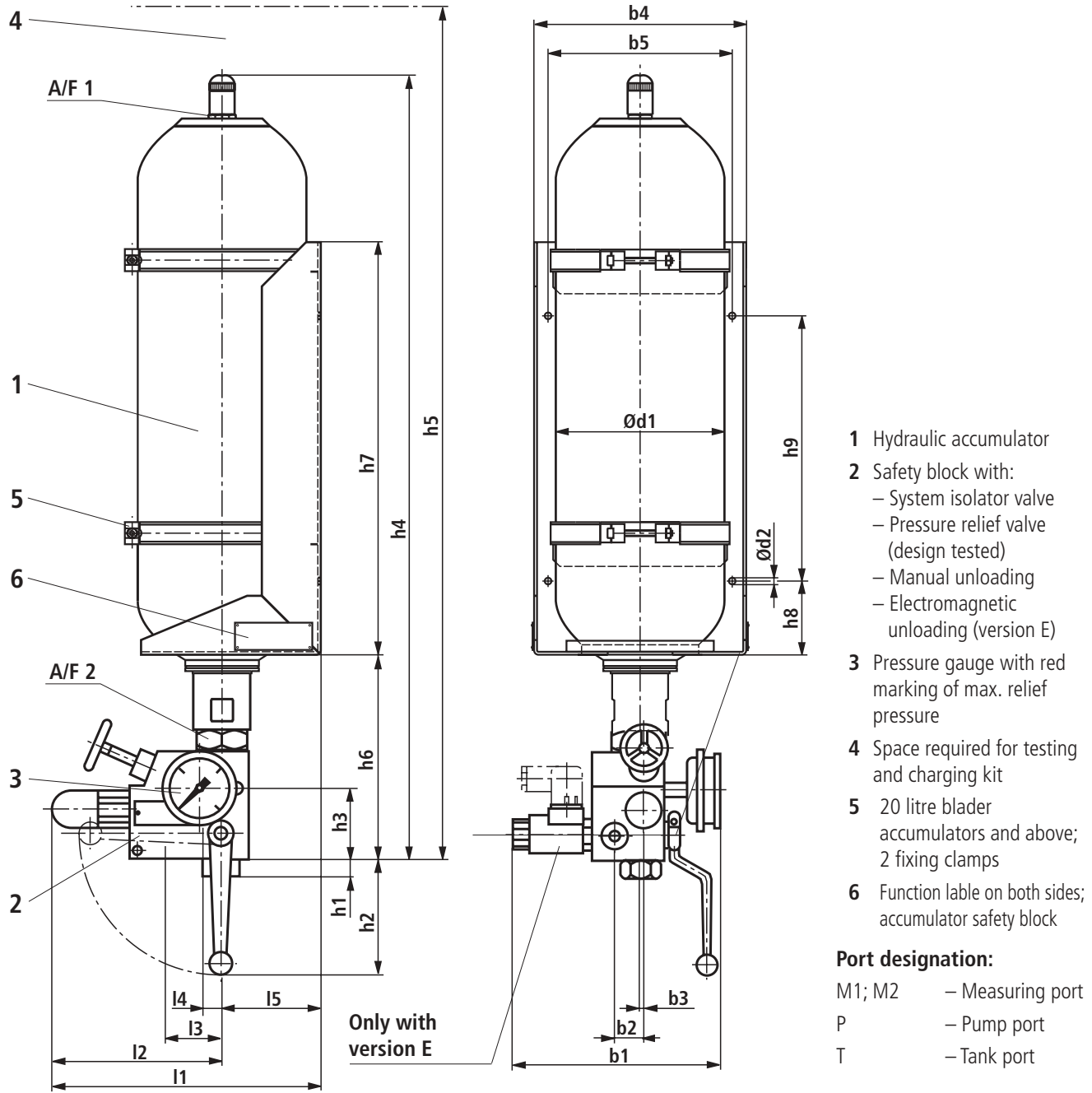

Kit ABSBG-...	Dimensions											
	b1	b2	b3	b4	b5	l1	l2	l3	l4	l5	Ød1	Ød2
B4,0/SS10-...	188	24	2	210	170	254	157	50	20	97	173	7
B10/SS20-...	238	17,5	7	288	250	292	165	56	32	127	222	9
B20/SS20-...						295						
B32/SS30-...	254	28	2			320	190	80	45	130	229	11
B50/SS30-...						320						

Kit ABSBG-...	Dimensions														
	h1	h2	h3	h4	h5	h6	h7	h8	h9	A/F1	A/F2	M1; M2	P	T	
B4,0/SS10-...	16	107	65	533	703	184	200	50	75	50			G1/2	G3/8	
B10/SS20-...	22	140	91	711	881	253	280	75	130	70			36	G1/4	G1
B20/SS20-...				1039	1209		560	100	360		G11/2	G1			
B32/SS30-...	21	174	97	1604	1774	303	1120	150	820						
B50/SS30-...				2124	2294										G11/2

Unit dimensions (dimensions in mm)

Accumulator assembly with diaphragm type accumulator 0.6 to 2.0 litres

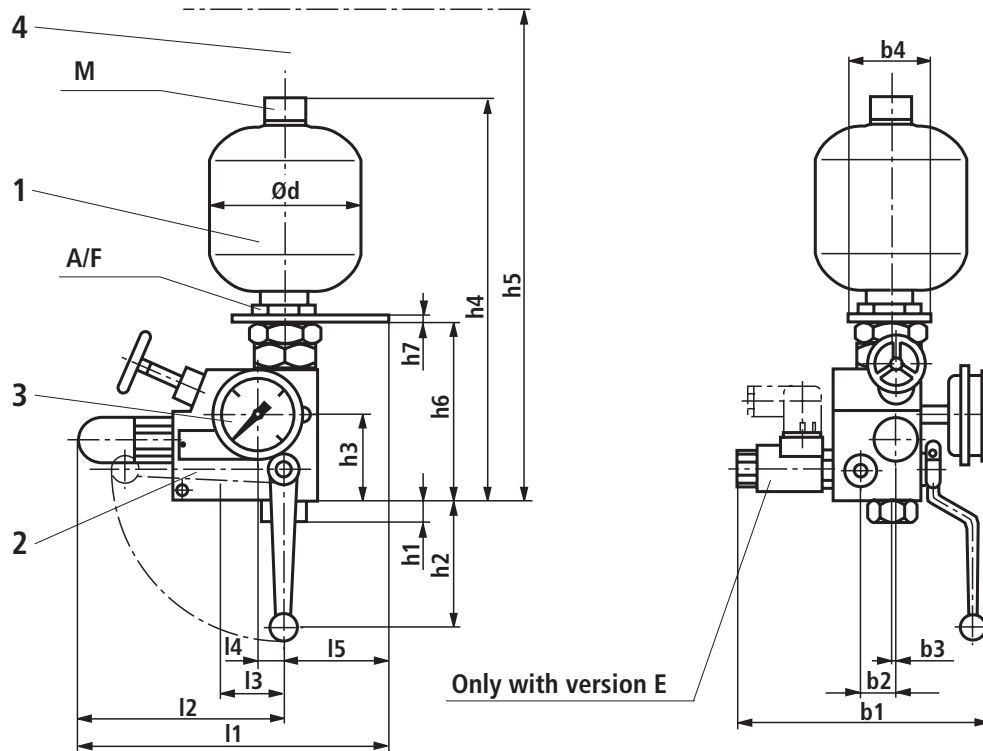

Kit ABSBG-...	b1	b2	b3	b4	l1	l2	l3	l4	l5	h1	h2	h3
M0,6/SS10-U-330-EG24NK4CM/C	205	24	2	60	237	157	50	20	80	16	107	65
M0,75/SS10-U-210-EG24NK4CM/C	205	24	2	60	237	157	50	20	80	16	107	65
M1,4/SS10-U-140-EG24NK4CM/C	205	24	2	60	237	157	50	20	80	16	107	65
M2,0/SS10-U-100-EG24NK4CM/C	205	24	2	80	262	157	50	20	105	16	107	65

Kit ABSBG-...	h4	h5	h6	h7	d	A/F	M	M1; M2	P	T
M0,6/SS10-U-330-EG24NK4CM/C	307	420	135	5	11	41	M28x1.5	G 1/4	G 1/2	G 3/8
M0,75/SS10-U-210-EG24NK4CM/C	303	416	135	5	121	41	M28x1.5	G 1/4	G 1/2	G 3/8
M1,4/SS10-U-140-EG24NK4CM/C	329	442	135	5	145	41	M28x1.5	G 1/4	G 1/2	G 3/8
M2,0/SS10-U-100-EG24NK4CM/C	343	456	135	5	160	46	M28x1.5	G 1/4	G 1/2	G 3/8

- 1 Hydraulic accumulator
- 2 Safety block with:
 - System isolator valve
 - Pressure relief valve (design tested)
 - Manual unloading
 - Electro-magnetic unloading (version E)
- 3 Pressure gauge with red marking of max. relief pressure
- 4 Space required for testing and charging kit

Port designation:

- M1; M2 – Measuring port
- P – Pump port
- T – Tank port

Notes on commissioning, maintenance and operation

General

- The hydraulic accumulators contained within these assemblies comply with directive 97/23/EC (component directive).
- The assemblies comprise all of the components that are required to conform to the safety requirements laid down in DIN 24 552.
- The assemblies must not be modified, otherwise the warranty becomes void.
- Repairs may only be carried out by the manufacturer or his authorised dealers and subsidiaries. If repair work is carried out by the customer, warranty rights are cancelled.
- The assemblies must be installed, serviced and repaired by authorised, trained and instructed personnel.
- The assemblies must only be operated within the permissible limits.
- The generally valid safety regulations and regulations for the prevention of accidents must be observed.
- National pressure vessels regulations of the country of installation have to be observed.
The country of installation must be stated on the order.

Commissioning

- Before the hydraulic accumulator is commissioned for the first time it must be charged with nitrogen. The gas pre-charge pressure required for operation is specified in hydraulic circuit diagrams and operating instructions.
- For charging, use only suitable charging and testing equipment.

Maintenance

- The gas pre-charge must be checked at regular intervals.
- Loss of the gas pre-charge while the system is continued to be operated results in damage to the accumulator bladder or accumulator diaphragm, respectively. If the accumulator bladder or diaphragm is damaged, the accumulator is immediately inoperable.

 **Caution!**
Warning

- Hydraulic accumulators store energy.
Before carrying out repair work, depressurise the system on the fluid side.
- The accumulator assembly comes with a warning sign. This must be fitted near the accumulator assembly in a clearly visible position.

Notes in accordance with EC Machinery Directive 98/37/EC, Annex II, Section B, manufacturer's declaration:

The assemblies have been manufactured in accordance with the harmonised standards EN 982, EN 983, EN 292 and EN 60 204-1.

Commissioning is strictly prohibited until evidence has been furnished that the machine, into which the assemblies are to be installed, are also in compliance with the regulations of EC Directives.

Engineering notes

Comprehensive notes and suggestions can be found in The Hydraulic Trainer, volume 3 RE 00 281, "Planning Hydraulic Systems".

Bosch Rexroth AG Industrial Hydraulics

D-97813 Lohr am Main
Zum Eisengießer 1 • D-97816 Lohr am Main
Telefon 0 93 52 / 18-0
Telefax 0 93 52 / 18-23 58 • Telex 6 89 418-0
eMail documentation@boschrexroth.de
Internet www.boschrexroth.de

Bosch Rexroth Limited

Cromwell Road, St Neots
Cambs, PE19 2ES
Tel: 0 14 80/22 32 56
Fax: 0 14 80/21 90 52
E-mail: info@boschrexroth.co.uk

The data specified above only serves to describe the product. No statements concerning a certain condition or suitability for a certain application can be derived from our information. The details stated do not release you from the responsibility for carrying out your own assessment and verification. It must be remembered that our products are subject to a natural process of wear and ageing.