

RE 26 570/02.03

Replaces: 11.02

**Pressure reducing valve, direct operated,
Type ZDR 6 D**

Nominal size 6

Series 4X

Maximum operating pressure 210 bar

Maximum flow 50 L/min

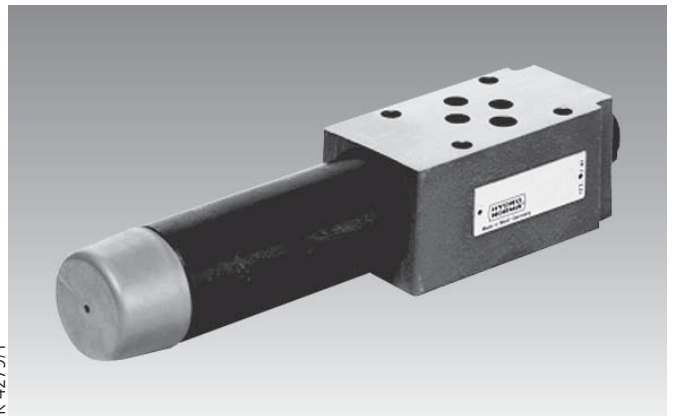

K 4279/1

Type ZDR 6 DP2-4X/...YM...

Overview of contents

Contents	Page
Features	1
Ordering details	2
Preferred types	2
Symbols	2
Function, section	3
Characteristic curves	4
Technical data	5
Unit dimensions	6

Features

- Sandwich plate design
- Porting pattern to DIN 24 340 Form A, **without** locating pin hole (standard)
- Porting pattern to ISO 4401 and CETOP-RP 121 H, **with** locating pin hole, (ordering code .../60 at the end of the valve type code)
- 4 pressure stages
- 4 adjustment elements:
 - Rotary knob
 - Sleeve with hexagon and protective cap
 - Lockable rotary knob with scale
 - Rotary knob with scale
- Pressure reduction in ports A, B or P
- Check valve, optional (only ZDR 6 DA...)



© 2003
by Bosch Rexroth AG, Industrial Hydraulics, D-97813 Lohr am Main

All rights reserved. No part of this document may be reproduced or stored, processed, duplicated or circulated using electronic systems, in any form or by any means, without the prior written authorisation of Bosch Rexroth AG. In the event of contravention of the above provisions, the contravening party is obliged to pay compensation.

Ordering details

Z	DR	6	D		-4X/	Y			*
Sandwich plate	= Z								Further details in clear text
Pressure reducing valve	= DR								No code = Without locating pin hole /60 ²⁾ = With locating pin hole
Nominal size 6	= 6								
Direct operated	= D								No code = NBR seals V = FKM seals (other seals on request)
Pressure reduction in port A2	= A								⚠ Attention! The compatibility of the seals and pressure fluid has to be taken into account!
Pressure reduction in port B2	= B								
Pressure reduction in port P1	= P								
Adjustment elements									
Rotary knob	= 1								No code = With check valve (only possible for pressure reduction in port A2)
Sleeve with hexagon and protective cap	= 2								M = Without check valve
Lockable rotary knob with scale	= 3 ¹⁾								
Rotary knob with scale	= 7								Y = Internal pilot oil supply, external leakage oil drain
Series 40 to 49	= 4X								
(40 to 49: unchanged installation and connection dimensions)									
									25 = Max. secondary pressure 25 bar
									75 = Max. secondary pressure 75 bar
									150 = Max. secondary pressure 150 bar
									210 = Max. secondary pressure 210 bar

¹⁾ H-key with Material No. **R900008158** is included within the scope of supply.

²⁾ Locating pin 3 x 8 DIN EN ISO 8752, Material No. **R900005694** (separate order)

Preferred types (readily available)

Type	Material number
ZDR 6 DA2-4X/25Y	R900410808
ZDR 6 DA2-4X/75Y	R900410813
ZDR 6 DA2-4X/150Y	R900410849
ZDR 6 DA2-4X/210Y	R900410855
ZDR 6 DB2-4X/25YM	R900449839
ZDR 6 DB2-4X/75YM	R900431771
ZDR 6 DB2-4X/150YM	R900431172
ZDR 6 DB2-4X/210YM	R900463269

Type	Material number
ZDR 6 DP2-4X/25YM	R900483785
ZDR 6 DP2-4X/75YM	R900483786
ZDR 6 DP2-4X/150YM	R900483787
ZDR 6 DP2-4X/210YM	R900483788

Further preferred types and standard units can be found in the EPS (Standard Price List).

Symbols (① = component side, ② = subplate side)

Type ZDR 6 DP..-4X/...YM...

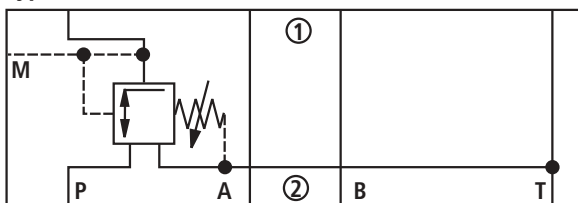

Type ZDR 6 DA..-4X/...YM...

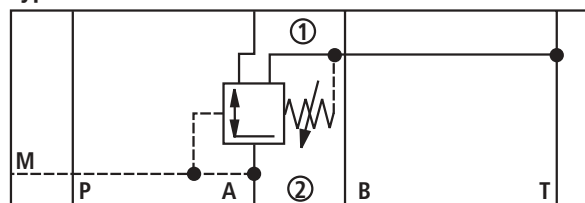

Type ZDR 6 DB..-4X/...YM...

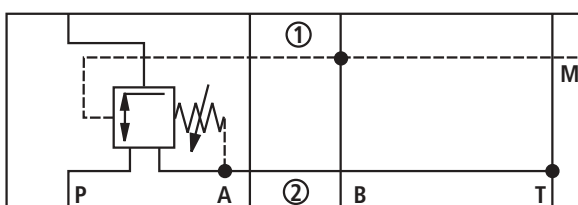

Type ZDR 6 DA..-4X/...Y...

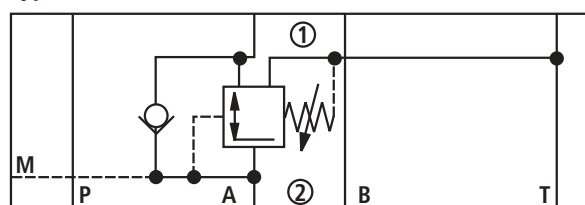

Function, section

Pressure reducing valves type ZDR 6 D.. are 3-way direct operated pressure reducing valves of sandwich plate design with a pressure relief function on the secondary side. It is used to reduce a system pressure. The pressure reducing valve basically consists of the housing (1), the control spool (2), a compression spring (3) and the adjustment element (4) as well as with an optional check valve. The secondary pressure is set by the pressure adjustment element (4).

Version "DA"

At rest, the valve is normally open and fluid can flow unhindered from port A1 to port A2. The pressure in port A2 is at the same time via the control line (5) present at the spool area opposite to the compression spring (3). When the pressure in port A2 exceeds the pressure level set at the compression spring (3), the control spool (2) moves into the control position then holds the set pressure in port A2 constant. The control pressure and pilot oil are taken from port A2 via control line (5). If the pressure in port A2 rises still further due to external forces, the control spool (2) moves still further towards the compression spring (3).

This causes a flow path to be opened at port A2 over the control spool (2) to tank. Sufficient fluid then flows to tank to prevent any further rise in pressure. The spring chamber (7) is always drained to tank externally via drilling (6) to port T (Y). A pressure gauge port (8) permits the secondary pressure at the valve to be monitored.

It is only possible to fit a check valve for free-flow in ports A2 to A1 in version "DA".

Versions "DP" and "DB"

In version DP, the pressure is reduced in port P1. The control pressure and the pilot oil is taken internally from port P1.

In version DB, the pressure in port P1 is reduced and the pilot oil is taken from port B.

⚠ Attention!

In version DB, it must be ensured that the pressure in port B is not higher than the set pressure when the directional valve is in position P to A, otherwise pressure in port A will be reduced.

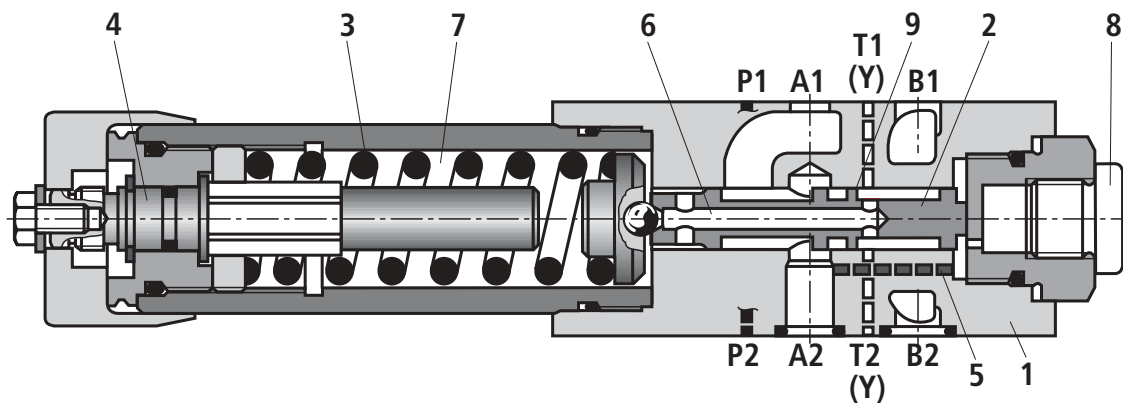

Type ZDR 6 DA1-4X/...YM...

Characteristic curves (measured with HLP46, $\vartheta_{oil} = 40 \text{ °C} \pm 5 \text{ °C}$)

Type ZDR 6 DA

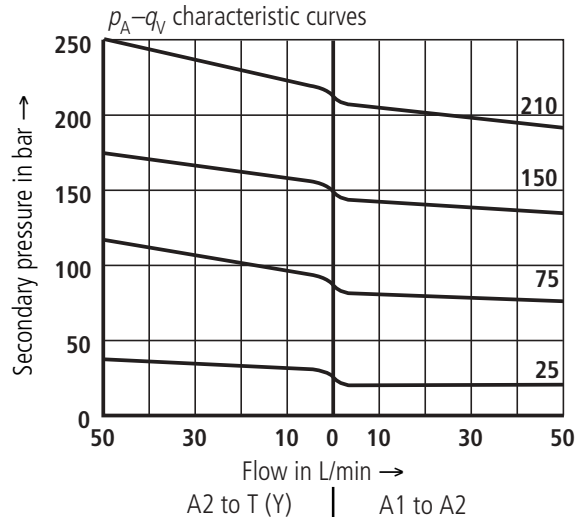

Typ ZDR 6 DP und ZDR 6 DB

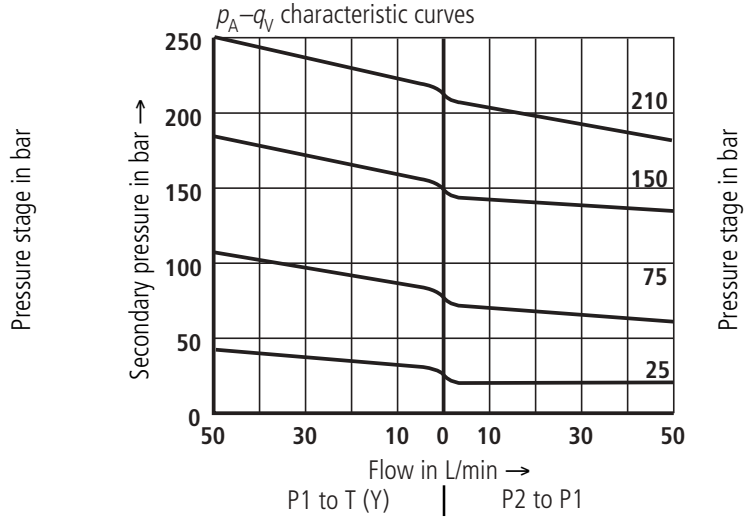

Note: The curve characteristics remain with, low set pressures, the same in relation to the pressure rating

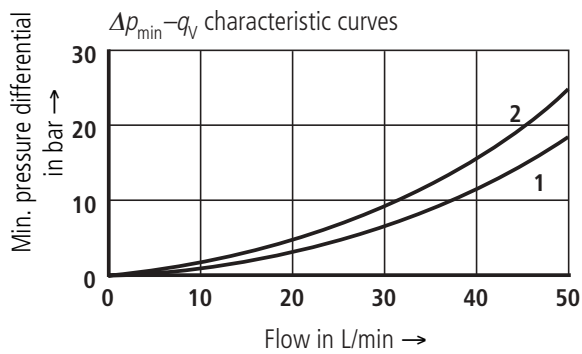

- 1 A1 to A2
- 2 A2 to T (Y) (3. way)

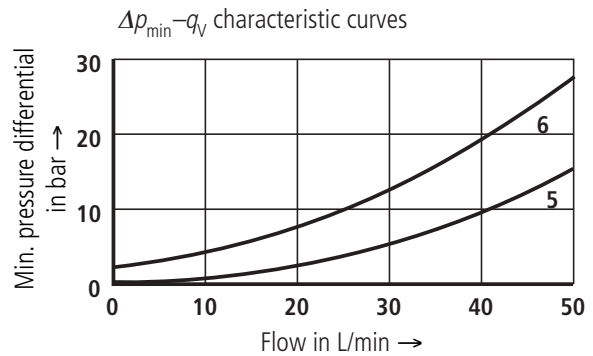

- 5 P2 to P1
- 6 P1 to T (Y) (3. way)

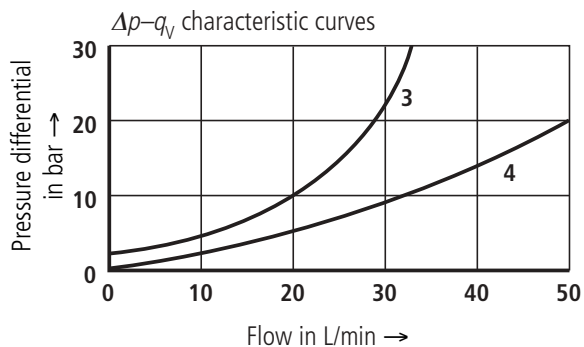

- 3 A2 to A1 flow via check valve only
- 4 A2 to A1 flow via check valve and fully open control cross-section

The characteristic curves for the pressure relief function are valid for the outlet pressure = zero over the entire flow range!

Technical data (for applications outside these parameters, please consult us!)**General**

Installation		Optional
Ambient temperature range	°C	– 30 to + 80 (NBR seals) – 20 to + 80 (FKM seals)
Weight	kg	Approx. 1.2

Hydraulic

Pressure fluid		Mineral oil (HL, HLP) to DIN 51 524 ¹⁾ ; Fast bio-degradable pressure fluids to VDMA 24 568 (also see RE 90 221); HETG (rape seed oil) ¹⁾ ; HEPG (polyglycols) ²⁾ ; HEES (synthetic ester) ²⁾ ; Other pressure fluids on request
Pressure fluid temperature range	°C	– 30 ... + 80 (NBR seals) – 20 ... + 80 (FKM seals)
Viscosity range	mm ² /s	10 ... 800
Cleanliness class to ISO code		Maximum permissible degree of contamination of the pressure fluid is to ISO 4406 (C) class 20/18/15 ³⁾
Maximum operating pressure (inlet)	bar	315
Secondary pressure (output)	bar	25; 75; 150; 210
Back pressure port T(Y)	bar	160
Maximum flow	L/min	50

1) Suitable for NBR **and** FKM seals

2) **Only** suitable for FKM seals

3) The cleanliness class stated for the components must be adhered too in hydraulic systems. Effective filtration prevents faults from occurring and at the same time increase the component service life.
For the selection of filters see catalogue sheets RE 50 070, RE 50 076 and RE 50 081.

Unit dimensions (dimensions in mm)

Types ZDR 6 DP and ZDR 6 DB

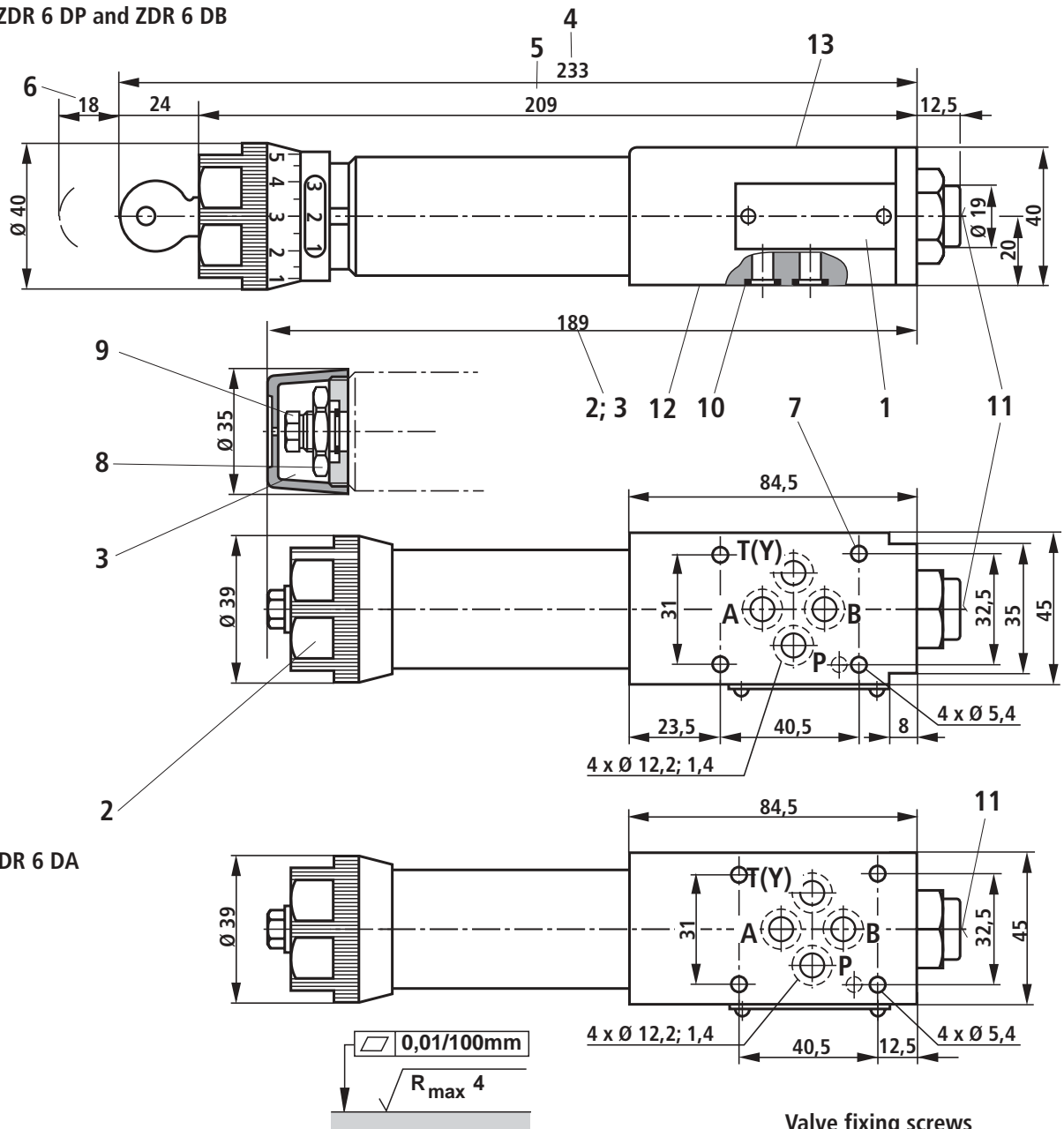

Type ZDR 6 DA

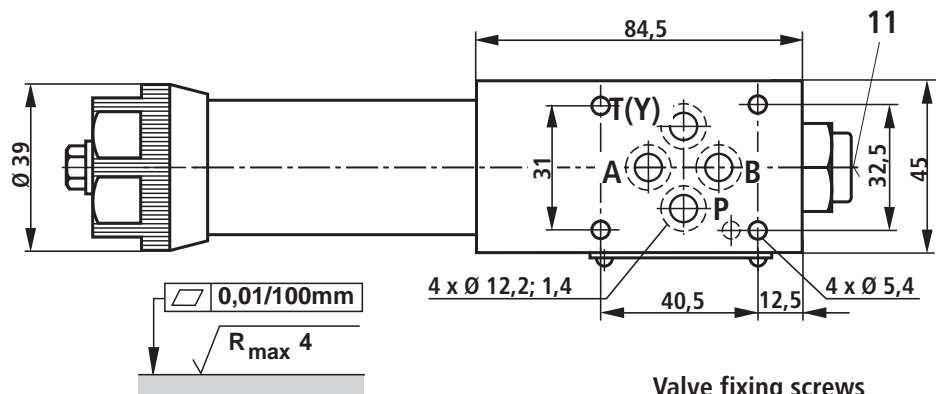

Valve fixing screws

M5 DIN 912-10.9,
Tightening torque $M_A = 8.9 \text{ Nm}$,
must be ordered separately

- 1 Name plate
- 2 Adjustment element "1"
- 3 Adjustment element "2"
- 4 Adjustment element "3"
- 5 Adjustment element "7"
- 6 Space required to remove the key
- 7 Valve fixing holes
- 8 Lock nut 24A/F
- 9 Hexagon 10A/F
- 10 Identical seal rings for ports A2, B2, P2, T2 (Y)

Required surface finish of the mating piece

- 11 Pressure gauge port G 1/4; 12 deep, internal hexagon 6A/F
- 12 Porting pattern to ISO 4401 and CETOP-RP 121 H, **with** locating pin hole, $\text{Ø}3 \times 5 \text{ mm}$ deep for locating pin $\text{Ø}3 \times 8 \text{ mm}$ DIN EN ISO 8752, Material No. **R900005694** (separate order)
- 13 Porting pattern to ISO 4401 and CETOP-RP 121 H, **with** locating pin hole, $\text{Ø}4 \times 4 \text{ mm}$ deep

Bosch Rexroth AG Industrial Hydraulics

D-97813 Lohr am Main
Zum Eisengießer 1 • D-97816 Lohr am Main
Telefon 0 93 52 / 18-0
Telefax 0 93 52 / 18-23 58 • Telex 6 89 418-0
eMail documentation@boschrexroth.de
Internet www.boschrexroth.de

Bosch Rexroth Limited

Cromwell Road, St Neots,
Cambs, PE19 2ES
Tel: 0 14 80/22 32 56
Fax: 0 14 80/21 90 52
E-mail: info@boschrexroth.co.uk

The data specified above only serves to describe the product. No statements concerning a certain condition or suitability for a certain application can be derived from our information. The details stated do not release you from the responsibility for carrying out your own assessment and verification. It must be remembered that our products are subject to a natural process of wear and ageing.