

RE 17 337/02.03

Replaces: 07.02

**Hydraulic cylinder
Types CDH3 / CGH3**

Series 1X; 2X

Nominal pressure 350 bar (35 MPa)

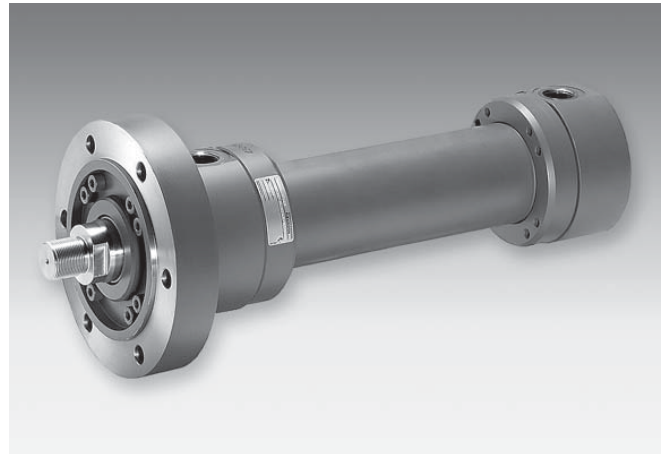

H/A 4645/95

Type CDH3MF3/...

Overview of contents

Contents	Page
Technical data	2
Areas, forces, flows	2
Ordering details	3
Cylinder weight	4
Tolerances	4
Mounting style overview	5
Plain clevis at base MP3	6
Self-aligning clevis at base MP5	8
Round flange at head MF3	10
Round flange at base MF4	12
Trunnions MT4	14
Foot mounting MS2	16
Flange connections	18
Position measuring system	20
Proximity switch	24
Coupling	26
Plain clevis	27
Self-aligning clevis	28
Buckling	31
End position cushioning	34
Spare parts	37
Tightening torques	39
Seal kits	40

Features

- 6 mounting styles
- Piston Ø: 40 to 320 mm
- Piston rod Ø: 28 to 220 mm
- Stroke lengths up to 6 m
- Self adjusting end position cushioning



© 2003
by Bosch Rexroth AG, Industrial Hydraulics, D-97813 Lohr am Main

All rights reserved. No part of this document may be reproduced or stored, processed, duplicated or circulated using electronic systems, in any form or by means, without the prior written authorisation of Bosch Rexroth AG. In the event of contravention of the above provisions, the contravening party is obliged to pay compensation.

Technical data

Standards:

Bosch Rexroth Standard; main dimensions such as piston \varnothing and piston rod \varnothing meet the requirements of DIN ISO 3320.

Nominal pressure: 350 bar

Static proof pressure: 525 bar

Higher operating pressures on request.

The specified operating pressures are only valid for applications with shock-free operation. If extreme loads occur, e.g. as happens in high sequence cycles, the fixings and piston rod thread connections need to be designed for durability (fatigue strength).

Installation: Optional

Pressure fluid:

Mineral oils DIN 51 524 (HL, HLP)

Phosphate ester (HFD-R; for seal version "C"
– 20 to +50 °C)

HFA (+5 bis +55 °C)

Water glycole HFC on request

Pressure fluid temperature range: – 20 to +80 °C

Viscosity range: 2.8 to 380 mm²/s

ISO cleanliness class

Maximum permissible degree of contamination of the pressure fluid is to ISO 4406 (C) class 20/18/15

Stroke velocity: Up to 0.5 m/s (depending on the connection ports)

Bleed screw as standard: Secured against unscrewing

Acceptance: Each cylinder is tested to Bosch Rexroth standards.

Cylinders whose application data lies outside the stated values can be offered as a special version.

Cylinders with piston $\varnothing > 320$ mm are available on request as an ABS (**A**pplication **B**ased **S**tandardisation) cylinder.

For assembly, commissioning and maintenance of hydraulic cylinders, please take the details stated within catalogue sheet RE 07100 into account!

Areas, forces, flows

Piston	Piston rod	Area ratio	Area			Force at 350 bar ¹⁾			Flow at 0.1 m/s ²⁾		
			Piston	Area Rod	annulus	Pressure	Diff.	Pulling	Out	Diff.	In
AL \varnothing mm	MM \varnothing mm	φ A_1/A_3	A_1 cm ²	A_2 cm ²	A_3 cm ²	F_1 kN	F_2 kN	F_3 kN	q_{V1} L/min	q_{V2} L/min	q_{V3} L/min
40	28	1.96	12.56	6.16	6.40	43.96	21.56	22.40	7.5	3.7	3.8
50	36	2.08	19.63	10.18	9.45	68.71	35.63	33.08	11.8	6.1	5.7
63	45	2.04	31.17	15.90	15.27	109.10	55.65	53.45	18.7	9.5	9.2
80	56	1.96	50.26	24.63	25.63	175.91	86.21	89.71	30.2	14.8	15.4
100	70	1.96	78.54	38.48	40.06	274.89	134.68	140.21	47.1	23.1	24.0
125	90	2.08	122.72	63.62	59.10	429.52	222.67	206.85	73.6	38.2	35.4
140	100	2.04	153.94	78.54	75.40	538.79	274.89	263.90	92.4	47.1	45.3
160	110	1.90	201.06	95.06	106.00	703.71	332.71	371.00	120.6	57.0	63.6
180	125	1.93	254.47	122.72	131.75	890.65	429.52	461.13	152.7	73.6	79.1
200	140	1.96	314.16	153.96	160.20	1099.56	538.86	560.70	188.5	92.4	96.1
220	160	2.12	380.1	201.0	179.1	1330.5	703.7	626.8	228.1	120.7	107.4
250	180	2.08	490.8	254.4	236.4	1718.1	890.6	827.4	294.5	152.7	141.8
280	200	2.04	615.7	314.1	301.6	2155.1	1099.6	1055.6	369.4	188.5	180.9
320	220	1.90	804.2	380.1	424.2	2814.9	1330.5	1484.4	482.5	228.1	254.4

Notes

¹⁾ Theoretical force (efficiency is not taken into account)

²⁾ Stroke velocity

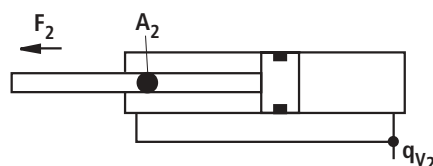
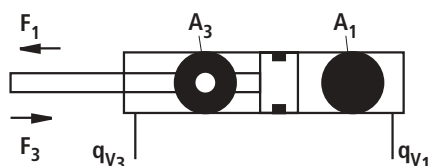

Ordering details

H3	/	/	/	A	/															
----	---	---	---	---	---	--	--	--	--	--	--	--	--	--	--	--	--	--	--	--

Differential cylinder = CD
Double rod cylinder ⁸⁾ = CG

Series = H3

Mounting styles

Plain clevis at base ¹⁾ = MP3
Self aligning clevis at base = MP5
Round flange at head = MF3
Round flange at base = MF4
Trunnions ²⁾ = MT4
Foot mounting = MS2

Piston Ø (40 to 320 mm)

See page 2

Piston rod Ø (28 to 220 mm)

See page 2

Stroke length in mm

Design principle

Head and base flanged = A

Series

10 to 19 unchanged installation and connection dimensions = 1X
Only piston Ø 40 to 200 mm
20 to 29 unchanged installation and connection dimensions = 2X
Only piston Ø 220 to 320 mm

Connection ports/version

Pipe thread to ISO 228/1 = B
Metric ISO thread = M
Flange porting pattern to ISO 6162 Tab.2 (ΔSAE 6000 PSI) ^{9), 10)} = D
Flange porting pattern to ISO 6164 Tab.2 ⁹⁾ = H

Connection port/position at head and base

1 = 1
2 = 2
3 = 3
4 = 4

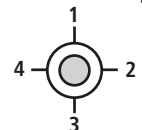

Viewed on the piston rod

Piston rod version

Hard chromium plated = C
Hardened and hard chromium plated ³⁾ = H
Nickel plated and hard chromium plated ⁴⁾ = N

Ordering examples:

CDH3 MT4/63/45/350A1X/B1CGDMWW, XV = 300 mm

CDH3 MF3/100/70/500A1X/B1CGUMWW

Notes

- ¹⁾ = Only piston Ø 40 to 200 mm
²⁾ = The trunnion can be located as required.
Dim. „XV“ must always be stated, in the case of an order, in clear text and in mm.
³⁾ = Only piston rod Ø 28 to 110 mm
⁴⁾ = Only piston rod Ø 28 to 140 mm
⁵⁾ = Only possible in conjunction with position measuring system „T“
⁶⁾ = Standard for seal versions M, T, S and piston Ø 220 to 320 mm;
Not possible for seal versions A, B

- ⁷⁾ = With the CG version only one plain clevis/self-aligning clevis is fitted
⁸⁾ = Only MF3; MT4; MS2
⁹⁾ = Not possible for MF4
¹⁰⁾ = Only piston Ø 63 to 320 mm
¹¹⁾ = With the CG version only one piston rod end
¹²⁾ = Only piston Ø 40 to 250 mm

Option 2
A = Maintenance free plain bearing
B = Flanged grease nipple
C = ⁵⁾ Analogue output 4-20 mA
F = ⁵⁾ Analogue output 0-10 V
D = ⁵⁾ Digital output SSI
Y = ¹¹⁾ Enter piston rod extension LY in clear text in mm
W = Without option

Option 1
A = Coupling, on both sides
F = ⁶⁾ Guide rings
E = Inductive proximity switch
Without plug-in connector
Plug-in connector – separate order, see page 24
T = ¹³⁾ Position measuring system (magnetostrictive)
Without plug-in connector
Plug-in connector – separate order, see page 23
W = Without option

Seal version
Suitable for mineral oil to DIN 51 524
HL, HLP and HFA
M = Standard seal system
T = Servo quality/reduced friction
A = Chevron seal kits

Suitable for phosphat ester
HFD-R
S = Servo quality/reduced friction
B = Chevron seal kits

End position cushioning
U = Without
D = ¹⁾ Both ends, self adjusting
E = Both side, adjustable

Piston rod end
A = Thread for self-aligning clevis CGAS
G = ¹²⁾ Thread for self-aligning clevis CGA, CGAK, plain clevis CSA
S = ⁷⁾ With mounted self-aligning clevis CGAS
L = ^{7), 12)} With mounted self-aligning clevis CGA
M = ^{7), 12)} With mounted self-aligning clevis CGAK
N = ^{7), 1)} With mounted plain clevis CSA

- ¹³⁾ = No possible for seal versions A, B;
Not possible for piston rod version „H“;
End position damping possible from piston rod Ø 45 mm;
Not possible for CG versions

Cylinder weight

Piston	Piston rod	CD cylinder at 0 mm stroke length					Per 100 mm stroke length	CG cylinder at 0 mm stroke length			Per 100 mm stroke length
AL	MM	MP3 MP5 1)	MP3 MP5 2)	MF3 MF4	MT4	MS2		MF3	MT4	MS2	
∅	∅	kg	kg	kg	kg	kg	kg	kg	kg	kg	kg
40	28	8	14	11	11	9	1.2	12	12	10	1.6
50	36	12	20	17	15	15	1.6	19	17	17	2.4
63	45	26	41	32	30	32	2.6	37	35	36	3.8
80	56	33	44.5	43	40	42	4.2	49	46	48	6.1
100	70	58	74.5	72	71	73	5.7	80	79	81	8.8
125	90	120	150	148	145	149	11.1	170	166	171	16.1
140	100	167	203	205	202	206	13.0	236	233	236	19.1
160	110	229	284	276	276	275	16.3	316	316	315	23.8
180	125	317	383	387	386	404	19.5	456	455	473	29.1
200	140	425	500	506	504	531	24.4	562	560	587	36.5
220	160	514	623	653	570	590	37.8	753	671	690	53.6
250	180	777	959	939	854	829	46.2	1057	972	948	66.2
280	200	915	1147	1073	1028	984	59.7	1224	1179	1135	84.3
320	220	1200	1479	1274	1211	1211	68.3	1431	1369	1369	98.1

Notes

- 1) = Weight without position measuring system
 2) = Weight with position measuring system

Tolerances to ISO 8135

Installation dimensions	WC	XC ²⁾	XO ²⁾	XS ^{1), 2)}	XV ²⁾	ZP ²⁾	Stroke tolerances
Mounting style	MF3	MP3	MP5	MS2	MT4	MF4	
Stroke length	Tolerances						
≤ 1250	± 2	± 1.5	± 1.5	± 2	± 2	± 1.5	+ 2
> 1250 – ≤ 3150	± 4	± 3	± 3	± 4	± 4	± 3	+ 5
> 3150 – ≤ 8000	± 8	± 5	± 5	± 8	± 8	± 5	+ 8

Notes

- 1) Not standardised
 2) Stroke length included

Mounting style overview

CDH3 MP3

See pages 6, 7

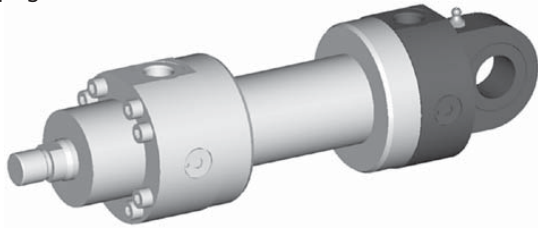

CDH3 MP5

See pages 8, 9

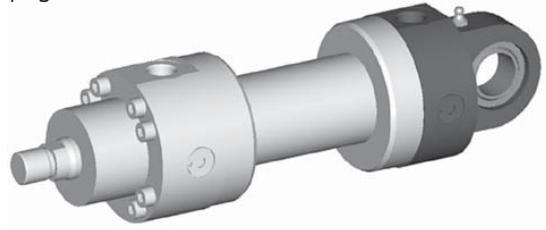

CDH3 MF3/ME7

See pages 10, 11

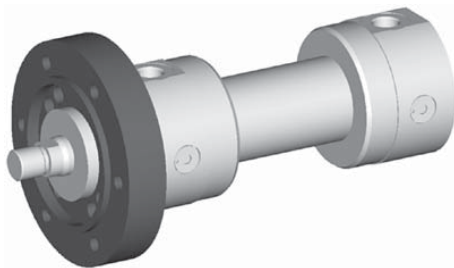

CGH3 MF3

See pages 10, 11

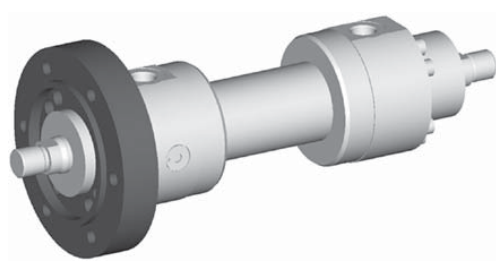

CDH3 MF4/ME8

See pages 12, 13

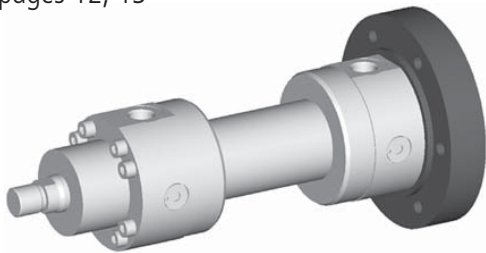

CDH3 MT4

See pages 14, 15

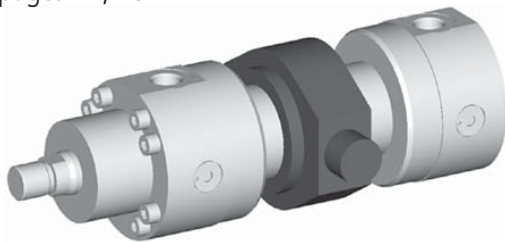

CGH3 MT4

See pages 14, 15

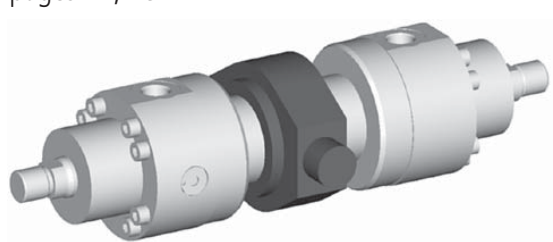

CDH3 MS2

See pages 16, 17

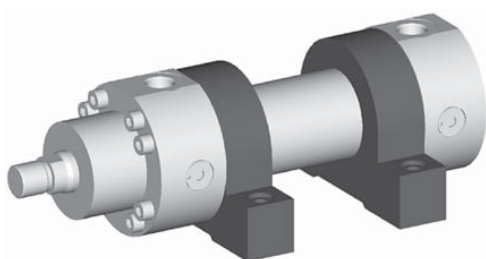

CGH3 MS2

See pages 16, 17

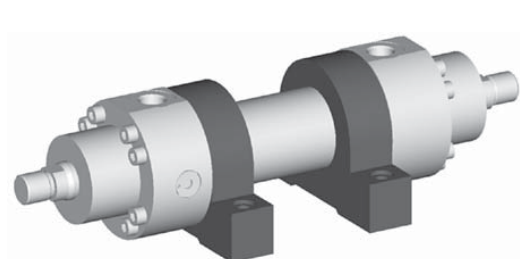

Plain clevis at base MP3

CDH3 MP3; AL-Ø 40-200 mm

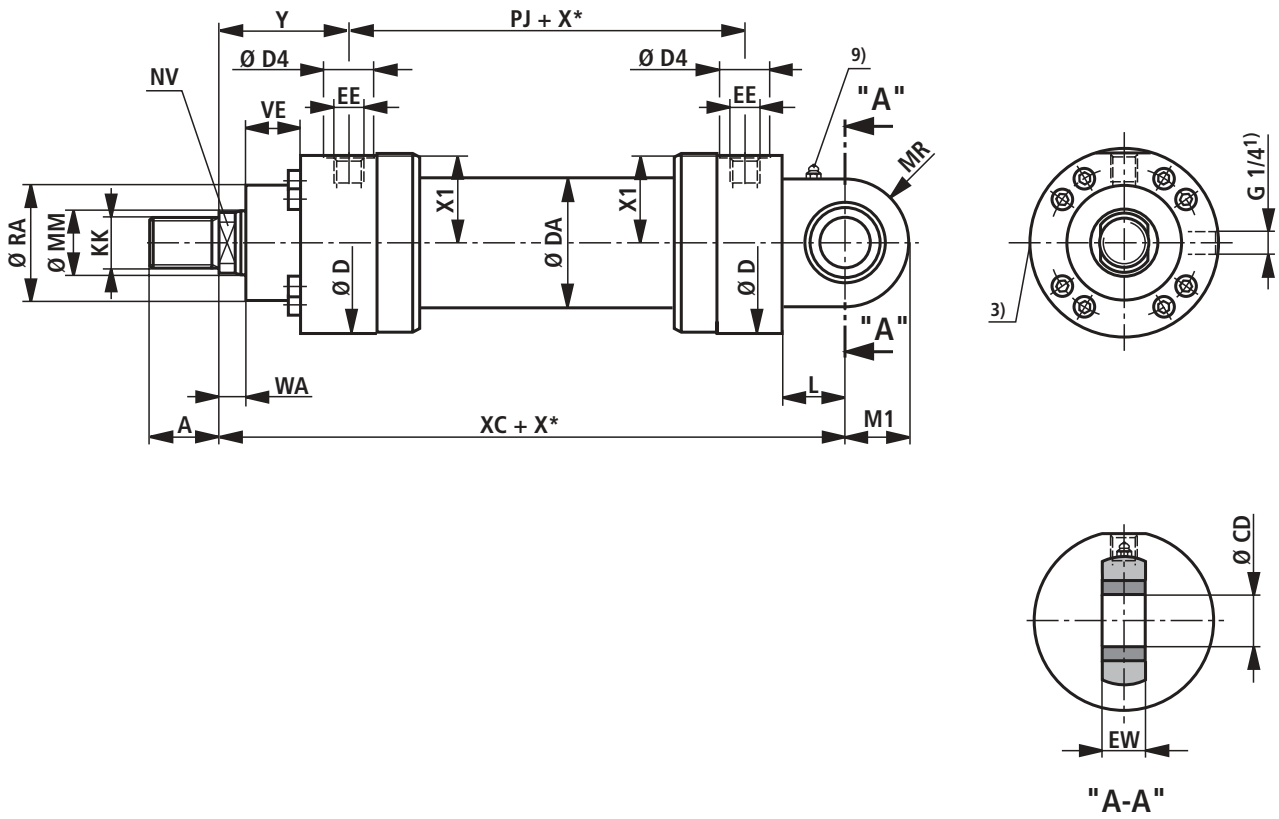

For seal versions „A“, „B“ and AL Ø 160 - 200 mm

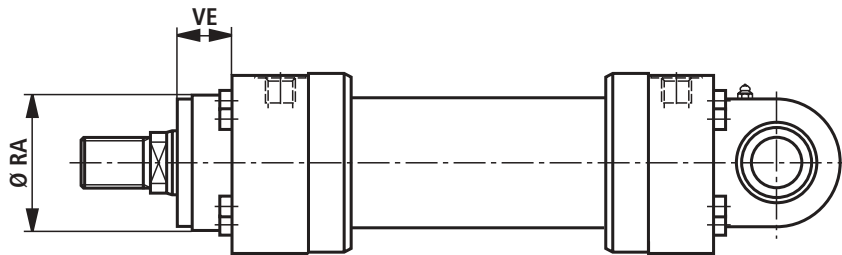

Dimensions MP3 (in mm)

AL Ø	MM Ø	KK 5)	A 5)	KK 6)	A 6)	NV	D	DA	D4 2)	EE 4)	EE 4)	Y	PJ	X1	WA
40	28	M22x1.5	22	M24x2	35	22	92	52	34	G1/2	M22x1.5	91	120	43	18
50	36	M28x1.5	28	M30x2	45	30	108	62	34	G1/2	M22x1.5	90	120	51.5	18
63	45	M35x1.5	35	M39x3	55	36	140	78	42	G3/4	M27x2	117	133	67	22
80	56	M45x1.5	45	M50x3	75	46	148	100	42	G3/4	M27x2	124	146	71.5	22
100	70	M58x1.5	58	M64x3	95	60	186	125	47	G1	M33x2	119	171	90.5	25
125	90	M65x1.5	65	M80x3	110	75	235	160	58	G1 1/4	M42x2	170	205	114	32
140	100	M80x2	80	M90x3	120	85	258	175	58	G1 1/4	M42x2	186	219	126	35
160	110	M100x2	100	M100x3	140	95	292	200	65	G1 1/2	M48x2	210	240	142.5	40
180	125	M110x2	110	M110x4	150	110	325	220	65	G1 1/2	M48x2	241	264	159.5	45
200	140	M120x3	120	M120x4	160	120	350	245	65	G1 1/2	M48x2	262	278	172.5	45

AL Ø	MM Ø	XC	L	MR	M1	CD H 11	EW h12	RA ⁷⁾ f8	VE ⁷⁾	RA ⁸⁾ f8	VE ⁸⁾
40	28	268	35	36	34	30	28	52	45	52	20
50	36	280	45	42	40	35	30	70	47	70	19
63	45	330	50	52	50	40	35	88	43	88	13
80	56	355	55	65	62.5	50	40	98	53	98	15
100	70	390	65	70	70	60	50	120	55	120	17
125	90	495	75	82	82	70	55	150	68	150	20
140	100	530	80	95	95	80	60	170	75	170	23
160	110	600	90	113	113	90	65	200	90	200	90
180	125	665	105	125	125	100	70	230	100	230	100
200	140	710	115	142.5	142.5	110	80	250	110	250	110

Notes

AL = Piston Ø

MM = Piston rod Ø

X* = Stroke length

1) = Bleeding: When viewed on the piston rod, the orientation is always off-set by 90° to the pipe connection (in a clockwise direction)

2) = Ø D4 max. 0.5 mm deep

3) = Throttle valve only with end position damping "E" (180° to the bleed point)

4) = For flange connections see separate table on pages 18 and 19

5) = Thread version „G“

6) = Thread version „A“

7) = Dimension for cylinder with seal versions M, T and S

8) = Dimension for cylinder with seal versions A and B

9) = Grease nipple; cone head form A to DIN 71 412

Self-aligning clevis at base MP5

CDH3 MP5

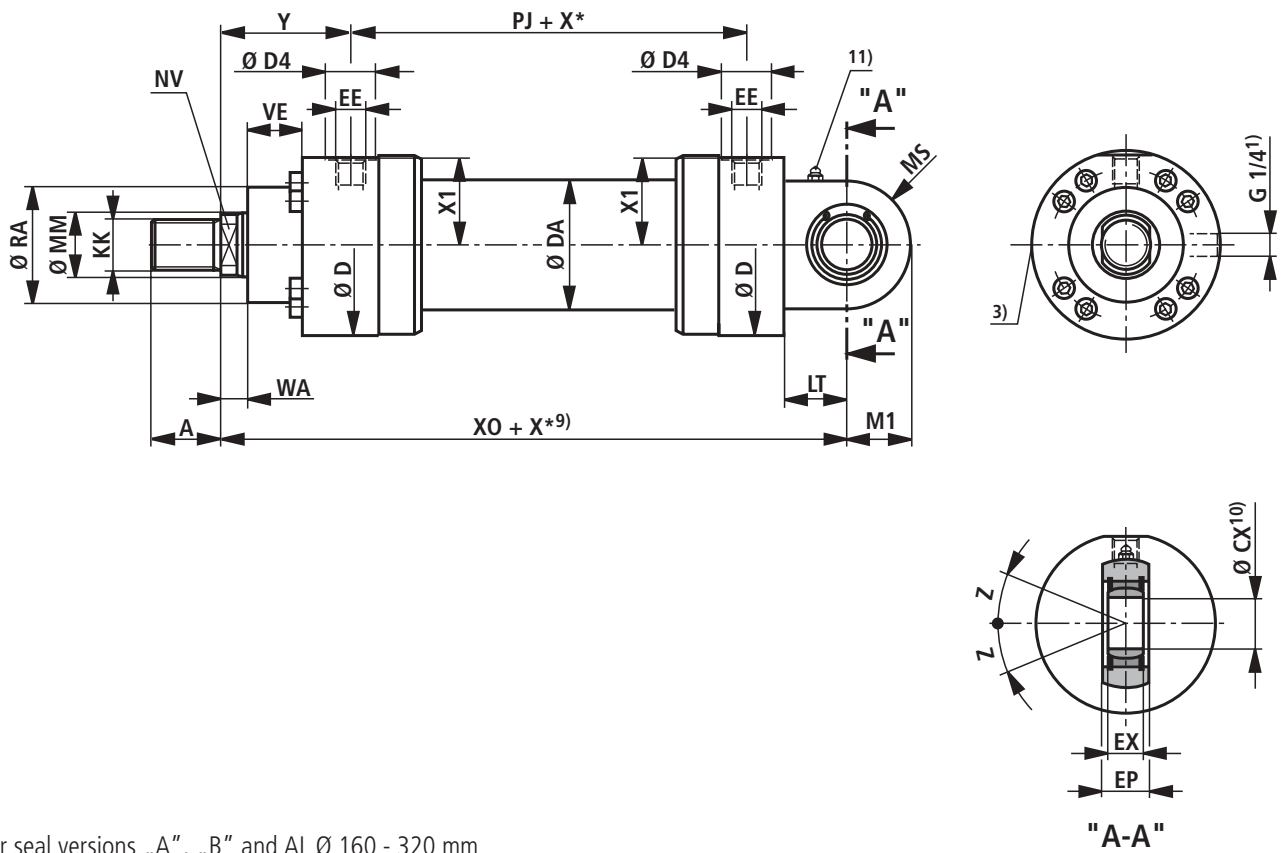

For seal versions „A“, „B“ and AL \emptyset 160 - 320 mm

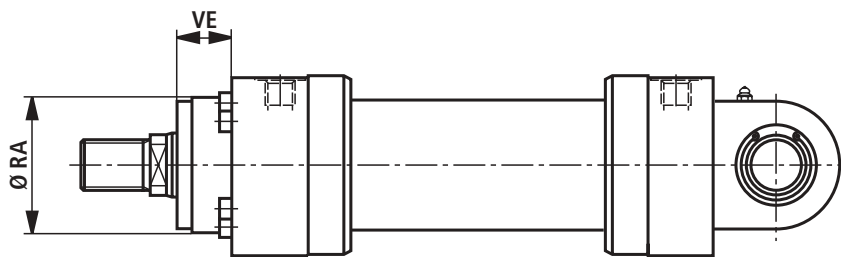

Dimensions MP5 (in mm)

AL Ø	MM Ø	KK 5)	A 5)	KK 6)	A 6)	NV	D	DA	D4 2)	EE 4)	EE 4)	Y	PJ	X1	WA	X0	X* min
40	28	M22x1.5	22	M24x2	35	22	92	52	34	G1/2	M22x1.5	91	120	43	18	268	–
50	36	M28x1.5	28	M30x2	45	30	108	62	34	G1/2	M22x1.5	90	120	51.5	18	280	–
63	45	M35x1.5	35	M39x3	55	36	140	78	42	G3/4	M27x2	117	133	67	22	330	–
80	56	M45x1.5	45	M50x3	75	46	148	100	42	G3/4	M27x2	124	146	71.5	22	355	–
100	70	M58x1.5	58	M64x3	95	60	186	125	47	G1	M33x2	119	171	90.5	25	390	–
125	90	M65x1.5	65	M80x3	110	75	235	160	58	G1 1/4	M42x2	170	205	114	32	495	–
140	100	M80x2	80	M90x3	120	85	258	175	58	G1 1/4	M42x2	186	219	126	35	530	–
160	110	M100x2	100	M100x3	140	95	292	200	65	G1 1/2	M48x2	210	240	142.5	40	600	–
180	125	M110x2	110	M110x4	150	110	325	220	65	G1 1/2	M48x2	241	264	159.5	45	665	–
200	140	M120x3	120	M120x4	160	120	350	245	65	G1 1/2	M48x2	262	278	172.5	45	710	–
220	160	M120x3	120	M120x4	160	140	375	292	65	G1 1/2	M48x2	262	326	185	40	760	–
250	180	M130x3	130	M150x4	190	160	440	324	65	G1 1/2	M48x2	272	336	218	40	825	20
280	200	–	–	M160x4	200	180	460	368	65	G1 1/2	M48x2	282	366	228	40	895	–
320	220	–	–	M180x4	220	200	490	406	65	G1 1/2	M48x2	287	391	243	40	965	340

AL Ø	MM Ø	LT	M1	MS	CX	EP	EX	Z	RA ⁷⁾ Ø f8	VE ⁷⁾	RA ⁸⁾ Ø f8	VE ⁸⁾
40	28	35	34	36	30 _{-0.010}	28 _{-0.4}	22 _{-0.12}	6°	52	45	52	20
50	36	45	40	52	35 _{-0.012}	30 _{-0.4}	25 _{-0.12}	6°	70	47	70	19
63	45	50	50	52	40 _{-0.012}	35 _{-0.4}	28 _{-0.12}	7°	88	43	88	13
80	56	55	62.5	65	50 _{-0.012}	40 _{-0.4}	35 _{-0.12}	6°	98	53	98	15
100	70	65	70	70	60 _{-0.015}	50 _{-0.4}	44 _{-0.15}	6°	120	55	120	17
125	90	75	82	82	70 _{-0.015}	55 _{-0.4}	49 _{-0.15}	6°	150	68	150	20
140	100	80	95	95	80 _{-0.015}	60 _{-0.4}	55 _{-0.15}	6°	170	75	170	23
160	110	90	113	113	90 _{-0.020}	65 _{-0.4}	60 _{-0.20}	5°	200	90	200	90
180	125	105	125	125	100 _{-0.020}	70 _{-0.4}	70 _{-0.20}	7°	230	100	230	100
200	140	115	142.5	142.5	110 _{-0.020}	80 _{-0.4}	70 _{0.20}	6°	250	110	250	110
220	160	115	142.5	142.5	110 _{-0.020}	80 _{-0.4}	70 _{-0.20}	6°	275	125	275	125
250	180	140	180	170	120 _{-0.020}	90 _{-0.4}	85 _{-0.20}	6°	320	135	320	135
280	200	170	200	190	140 _{-0.025}	100 _{-0.4}	90 _{-0.25}	7°	335	150	335	150
320	220	200	250	240	160 _{-0.025}	110 _{-0.4}	105 _{-0.25}	8°	350	165	350	165

Notes

AL = Piston Ø

MM = Piston rod Ø

X* = Stroke length

1) = Bleeding: When viewed on the piston rod, the orientation is always off-set by 90° to the pipe connection (in a clockwise direction)

2) = Ø D4 max. 0.5 mm deep

3) = Throttle valve only with end position damping "E" (180° to the bleed point)

4) = For flange connections see separate table on pages 18 and 19

5) = Thread version „G”

6) = Thread version „A”

7) = Dimension for cylinder with seal versions M, T and S

8) = Dimension for cylinder with seal versions A and B

9) = Take the minimum stroke length „X*min.” into account

10) = Associated pin Ø m6; associated pin Ø j6 with a maintenance free self-aligning clavis

11) = Grease nipple; cone head form A to DIN 71 412

Round flange at head MF3

CDH3 MF3

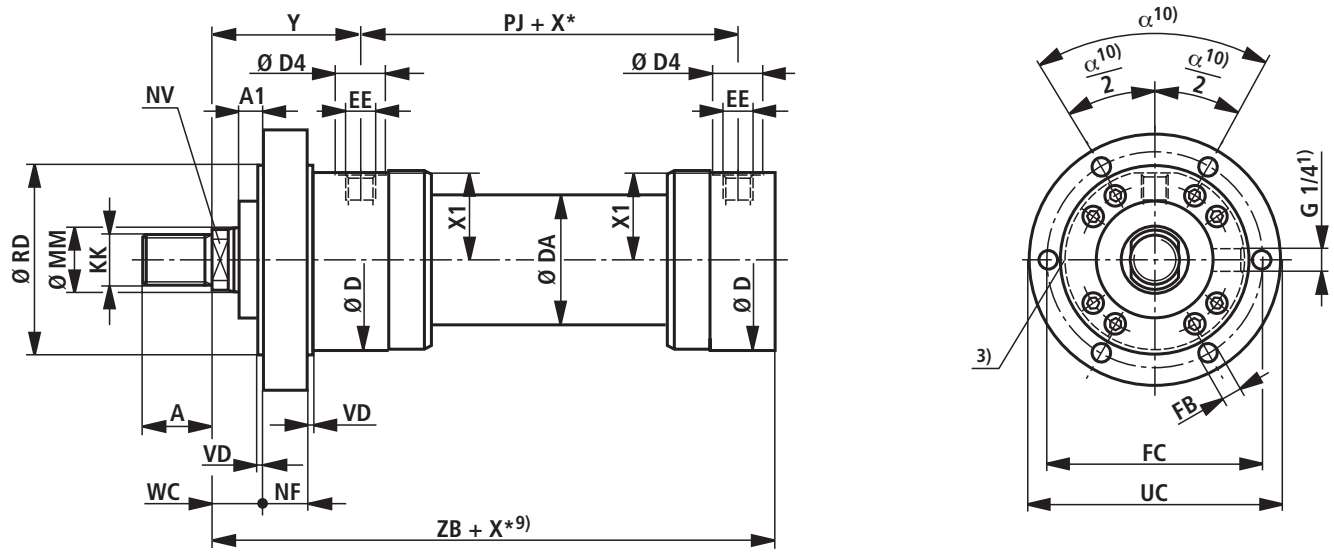

CGH3 MF3

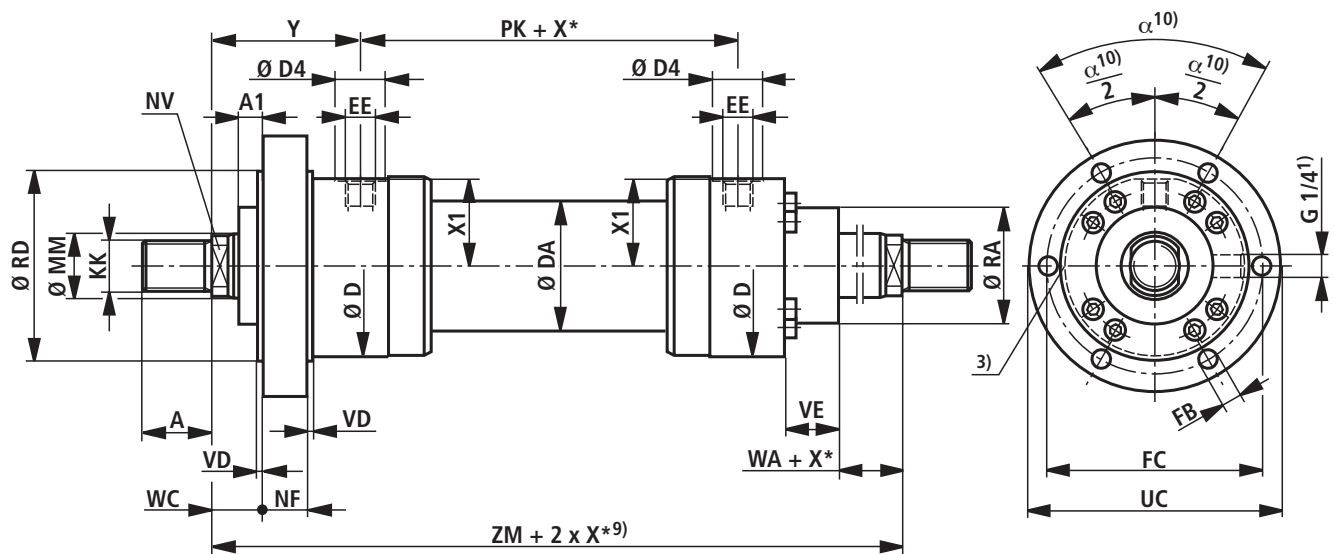

For seal versions „A“, „B“ and AL $\text{D } 160 - 320 \text{ mm}$

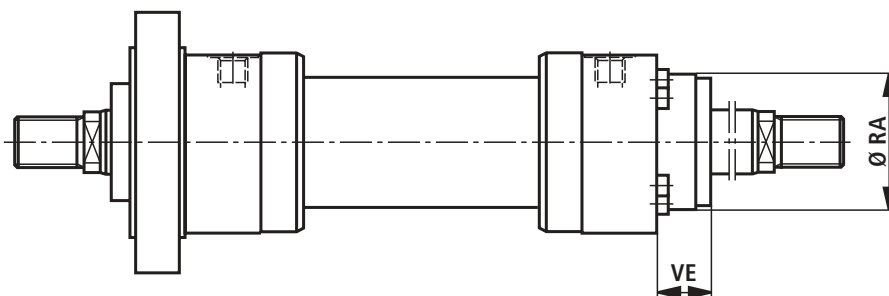

Dimensions MF3 (in mm)

AL Ø	MM Ø	KK 5)	A 5)	KK 6)	A 6)	NV	D	DA	D4 2)	EE 4)	EE 4)	Y	PJ	X1	RD e8	WC	VD
40	28	M22x1.5	22	M24x2	35	22	92	52	34	G1/2	M22x1,5	91	120	43	95	23	5
50	36	M28x1.5	28	M30x2	45	30	108	62	34	G1/2	M22x1,5	90	120	51.5	115	20	5
63	45	M35x1.5	35	M39x3	55	36	140	78	42	G3/4	M27x2	117	133	67	150	20	5
80	56	M45x1.5	45	M50x3	75	46	148	100	42	G3/4	M27x2	124	146	71.5	160	20	5
100	70	M58x1.5	58	M64x3	95	60	186	125	47	G1	M33x2	119	171	90.5	200	20	5
125	90	M65x1.5	65	M80x3	110	75	235	160	58	G1 1/4	M42x2	170	205	114	245	25	5
140	100	M80x2	80	M90x3	120	85	258	175	58	G1 1/4	M42x2	186	219	126	280	30	10
160	110	M100x2	100	M100x3	140	95	292	200	65	G1 1/2	M48x2	210	240	142.5	300	40	10
180	125	M110x2	110	M110x4	150	110	325	220	65	G1 1/2	M48x2	241	264	159.5	300	40	10
200	140	M120x3	120	M120x4	160	120	350	245	65	G1 1/2	M48x2	262	278	172.5	360	40	10
220	160	M120x3	120	M120x4	160	140	375	292	65	G1 1/2	M48x2	262	326	185	400	40	10
250	180	M130x3	130	M150x4	190	160	440	324	65	G1 1/2	M48x2	272	336	218	450	40	10
280	200	–	–	M160x4	200	180	460	368	65	G1 1/2	M48x2	282	366	228	470	50	10
320	220	–	–	M180x4	220	200	490	406	65	G1 1/2	M48x2	287	391	243	510	55	10

AL Ø	MM Ø	NF	PK	A1	ZB	ZM	X* min	FB H13	FC js13	UC -1	α	WA	RA ⁷⁾ f8	VE ⁷⁾	RA ⁸⁾ f8	VE ⁸⁾
40	28	35	120	0	238	302	–	13.5	120	145	60°	18	52	45	52	20
50	36	40	120	0	237	300	–	13.5	140	165	60°	18	70	47	70	19
63	45	40	133	0	285	367	–	17.5	180	210	60°	22	88	43	88	13
80	56	50	146	0	305	394	–	17.5	195	230	60°	22	98	53	98	15
100	70	55	171	0	330	409	–	22	230	270	60°	25	120	55	120	17
125	90	70	205	0	425	545	–	26	290	335	60°	32	150	68	150	20
140	100	70	219	0	457	591	–	30	330	380	60°	35	170	75	170	23
160	110	80	240	0	515	660	–	30	360	420	45°	40	200	90	200	90
180	125	95	264	0	565	746	–	36	400	470	45°	45	230	100	230	100
200	140	105	278	0	600	802	–	36	430	500	45°	45	250	110	250	110
220	160	115	326	20	6555	850	–	39	475	550	45°	40	275	125	275	125
250	180	125	336	30	695	880	20	45	530	610	45°	40	320	135	320	135
280	200	130	366	25	735	930	–	45	550	630	45°	40	335	150	335	150
220	220	140	391	25	775	965	340	45	590	670	30°	40	350	165	350	165

Notes

AL = Piston Ø

MM = Piston rod Ø

X* = Stroke length

1) = Bleeding: When viewed on the piston rod, the orientation is always off-set by 90° to the pipe connection (in a clockwise direction)

2) = Ø D4 max. 0.5 mm deep

3) = Throttle valve only with end position damping "E" (180° to the bleed point)

4) = For flange connections see separate table on pages 18 and 19

5) = Thread version „G”

6) = Thread version „A”

7) = Dimension for cylinder with seal versions M, T and S

8) = Dimension for cylinder with seal versions A and B

9) = Take the minimum stroke length „X*min.” into account

10) = For piston Ø 160 to 280 mm 8 fixing holes
For piston Ø 320 mm 12 fixing holes

Round flange at base MF4

CDH3 MF4

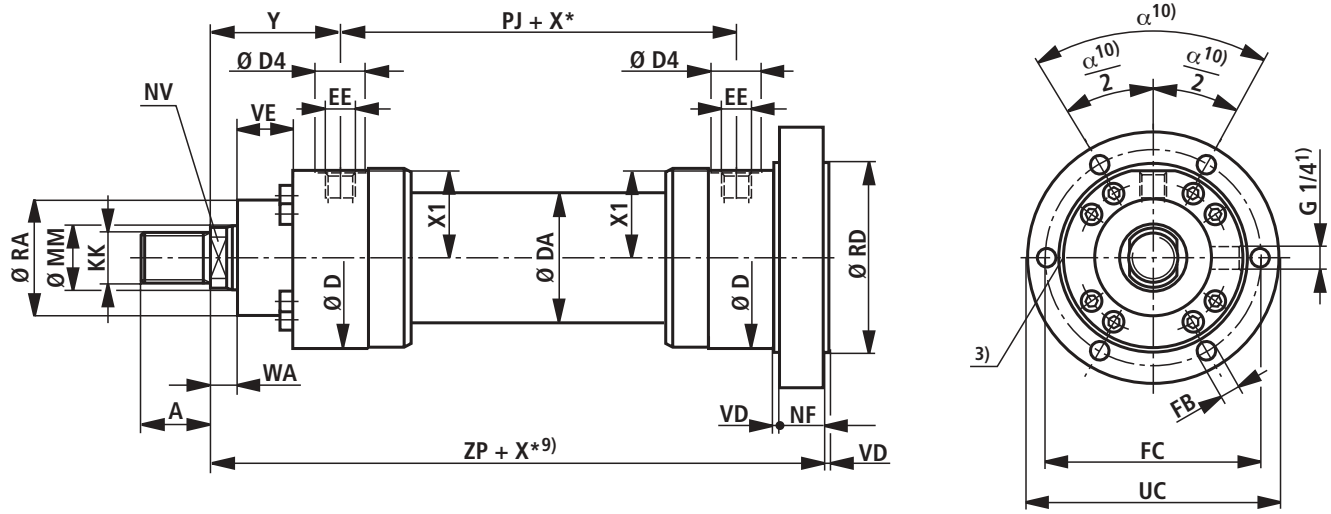

For seal versions „A”, „B” and AL $\text{D} 160 - 320 \text{ mm}$

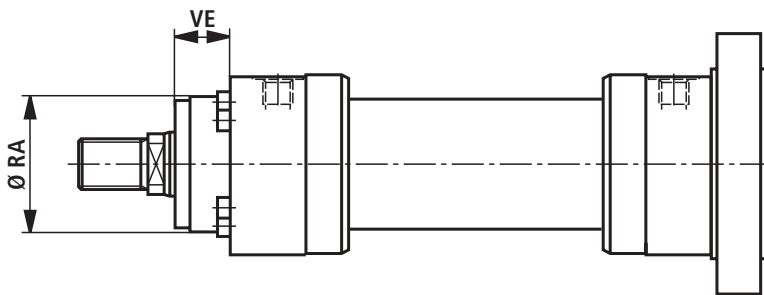

Dimensions MF4 (in mm)

AL Ø	MM Ø	KK 5)	A 5)	KK 6)	A 6)	NV	D	DA	D4 2)	EE 4)	EE 4)	Y	PJ	X1	WA
40	28	M22x1.5	22	M24x2	35	22	92	52	34	G1/2	M22x1.5	91	120	43	18
50	36	M28x1.5	28	M30x2	45	30	108	62	34	G1/2	M22x1.5	90	120	51.5	18
63	45	M35x1.5	35	M39x3	55	36	140	78	42	G3/4	M27x2	117	133	67	22
80	56	M45x1.5	45	M50x3	75	46	148	100	42	G3/4	M27x2	124	146	71.5	22
100	70	M58x1.5	58	M64x3	95	60	186	125	47	G1	M33x2	119	171	90.5	25
125	90	M65x1.5	65	M80x3	110	75	235	160	58	G1 1/4	M42x2	170	205	114	32
140	100	M80x2	80	M90x3	120	85	258	175	58	G1 1/4	M42x2	186	219	126	35
160	110	M100x2	100	M100x3	140	95	292	200	65	G1 1/2	M48x2	210	240	142.5	40
180	125	M110x2	110	M110x4	150	110	325	220	65	G1 1/2	M48x2	241	264	159.5	45
200	140	M120x3	120	M120x4	160	120	350	245	65	G1 1/2	M48x2	262	278	172.5	45
220	160	M120x3	120	M120x4	160	140	375	292	65	G1 1/2	M48x2	262	326	185	40
250	180	M130x3	130	M150x4	190	160	440	324	65	G1 1/2	M48x2	272	336	218	40
280	200	–	–	M160x4	200	180	460	368	65	G1 1/2	M48x2	282	366	228	40
320	220	–	–	M180x4	220	200	490	406	65	G1 1/2	M48x2	287	391	243	40

AL Ø	MM Ø	ZP	X* min	NF	VD	RD e8	FB H13	FC js13	UC -1	α	RA ⁷⁾ f8	VE ⁷⁾	RA ⁸⁾ f8	VE ⁸⁾
40	28	273	–	35	5	95	13.5	120	145	60°	52	45	52	20
50	36	277	–	40	5	115	13.5	140	165	60°	70	47	70	19
63	45	325	–	40	5	150	17.5	180	210	60°	88	43	88	13
80	56	355	–	50	5	160	17.5	195	230	60°	98	53	98	15
100	70	385	–	55	5	200	22	230	270	60°	120	55	120	17
125	90	495	–	70	5	245	26	290	335	60°	150	68	150	20
140	100	532	–	70	10	280	30	330	380	60°	170	75	170	23
160	110	600	–	80	10	300	30	330	380	60°	200	90	200	90
180	125	665	–	95	10	335	36	400	470	45°	230	100	230	100
200	140	710	–	105	10	360	36	430	500	45°	250	110	250	110
220	160	770	–	115	10	400	39	475	550	45°	275	125	275	125
250	180	820	20	125	10	450	45	530	610	45°	320	135	320	135
280	200	865	–	130	10	470	45	550	630	45°	335	150	335	150
320	220	915	340	140	10	510	45	590	670	30°	350	165	350	165

Notes

AL = Piston Ø

MM = Piston rod Ø

X* = Stroke length

1) = Bleeding: When viewed on the piston rod, the orientation is always off-set by 90° to the pipe connection (in a clockwise direction)

2) = Ø D4 max. 0.5 mm deep

3) = Throttle valve only with end position damping "E" (180° to the bleed point)

4) = Flange connections see separate table on pages 18 and 19

5) = Thread version „G“

6) = Thread version „A“

7) = Dimension for cylinder with seal versions M, T and S

8) = Dimension for cylinder with seal versions A and B

9) = Take the minimum stroke length „X*min.“ into account

10) = For piston Ø 160 to 280 mm 8 fixing holes
For piston Ø 320 mm 12 fixing holes

Trunnions MT4

CDH3 MT4

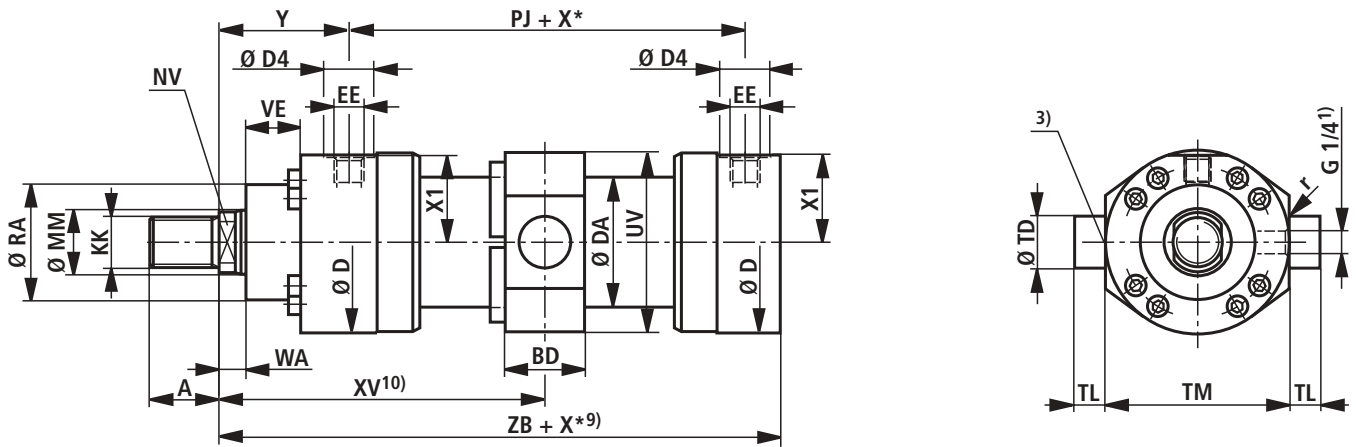

For seal versions „A“, „B“ and AL $\emptyset 160 - 320$ mm

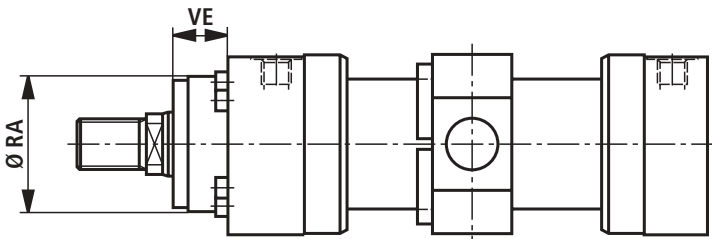

CGH3 MT4

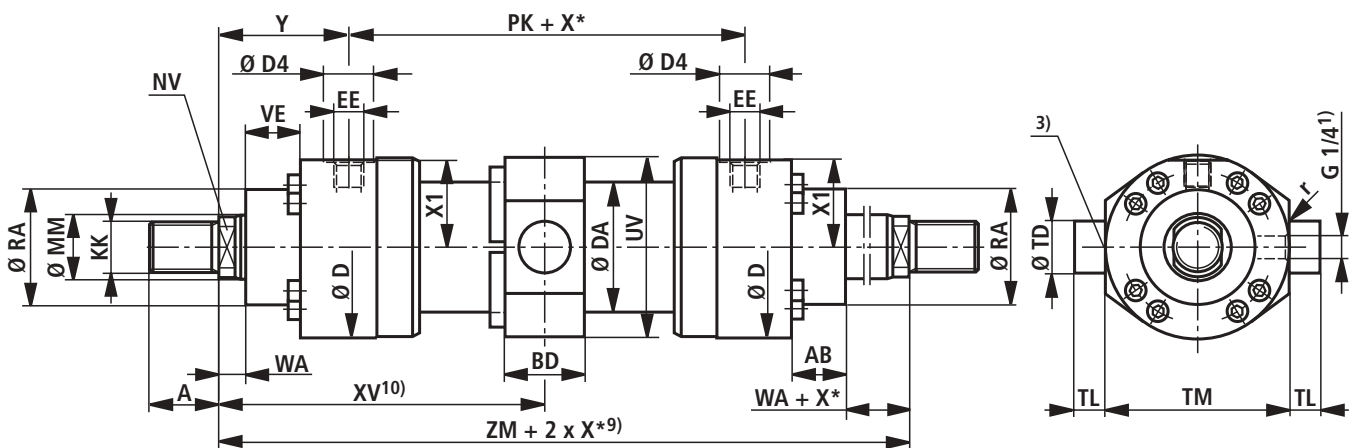

For seal versions „A“, „B“ and AL $\emptyset 160 - 320$ mm

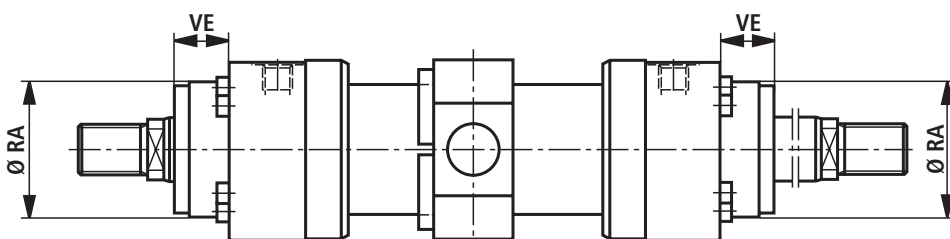

Dimensions MT4 (in mm)

AL Ø	MM Ø	KK 5)	A 5)	KK 6)	A 6)	NV	D	DA	D4 2)	EE 4)	EE 4)	Y	PJ	X1	WA	PK	ZB
40	28	M22x1.5	22	M24x2	35	22	92	52	34	G1/2	M22x1.5	91	120	43	18	120	238
50	36	M28x1.5	28	M30x2	45	30	108	62	34	G1/2	M22x1.5	90	120	51,5	18	120	237
63	45	M35x1.5	35	M39x3	55	36	140	78	42	G3/4	M27x2	117	133	67	22	133	285
80	56	M45x1.5	45	M50x3	75	46	148	100	42	G3/4	M27x2	124	146	71,5	22	146	305
100	70	M58x1.5	58	M64x3	95	60	186	125	47	G1	M33x2	119	171	90,5	25	171	330
125	90	M65x1.5	65	M80x3	110	75	235	160	58	G1 1/4	M42x2	170	205	114	32	205	425
140	100	M80x2	80	M90x3	120	85	258	175	58	G1 1/4	M42x2	186	219	126	35	219	457
160	110	M100x2	100	M100x3	140	95	292	200	65	G1 1/2	M48x2	210	240	142,5	40	240	515
180	125	M110x2	110	M110x4	150	110	325	220	65	G1 1/2	M48x2	241	264	159,5	45	264	565
200	140	M120x3	120	M120x4	160	120	350	245	65	G1 1/2	M48x2	262	278	172,5	45	278	600
220	160	M120x3	120	M120x4	160	140	375	292	65	G1 1/2	M48x2	262	326	185	40	326	655
250	180	M130x3	130	M150x4	190	160	440	324	65	G1 1/2	M48x2	272	336	218	40	336	695
280	200	–	–	M160x4	200	180	460	368	65	G1 1/2	M48x2	282	366	228	40	366	735
320	220	–	–	M180x4	220	200	490	406	65	G1 1/2	M48x2	287	391	243	40	391	775

AL Ø	MM Ø	ZM	X* min.	XV ¹⁾ mitt	XV min.	XV max.	BD	UV	TD e8	TL js16	TM h13	r	RA f8	VE ⁷⁾ f8	RA ⁸⁾ f8	VE ⁸⁾
40	28	302	42	151 + $\frac{X^*}{2}$	172	138+X*	48	92	40	30	95	2	52	45	52	20
50	36	300	50	150 + $\frac{X^*}{2}$	175	134+X*	48	108	40	30	120	2	70	47	70	19
63	45	367	64	183,5 + $\frac{X^*}{2}$	215,5	163,5+X*	53	140	45	35	150	2	88	43	88	13
80	56	384	82	197 + $\frac{X^*}{2}$	238	168+X*	68	156	55	50	160	2	98	53	98	15
100	70	409	109	204,5 + $\frac{X^*}{2}$	259	165+X*	88	186	60	55	200	2	120	55	120	17
125	90	545	131	272,5 + $\frac{X^*}{2}$	338	222+X*	118	235	75	60	245	2.5	150	68	150	20
140	100	591	147	295,5 + $\frac{X^*}{2}$	369	237+X*	128	265	85	70	280	2.5	170	75	170	23
160	110	660	186	330 + $\frac{X^*}{2}$	423	257+X*	148	292	95	80	300	2.5	200	90	200	90
180	125	746	212	373 + $\frac{X^*}{2}$	479	287+X*	168	325	110	90	335	2.5	230	100	230	100
200	140	802	228	401 + $\frac{X^*}{2}$	515	307+X*	188	350	120	100	360	2.5	250	110	250	110
220	160	850	205	425 + $\frac{X^*}{2}$	527.5	322.5+X*	165	375	130	100	400	2.5	275	125	275	125
250	180	880	245	440 + $\frac{X^*}{2}$	562.5	317.5+X*	175	440	140	100	450	5	320	135	320	135
280	200	930	245	465 + $\frac{X^*}{2}$	587.5	342.5+X*	205	460	170	125	480	5	335	150	335	150
320	220	965	600	482,5 + $\frac{X^*}{2}$	782.5	182.5+X*	245	510	200	150	500	5	350	165	350	165

Notes

- | | |
|--|--|
| AL = Piston Ø | 5) = Thread version „G“ |
| MM = Piston rod Ø | 6) = Thread version „A“ |
| X* = Stroke length | 7) = Dimension for cylinder with seal versions M, T and S |
| 1) = Bleeding: When viewed on the piston rod, the orientation is always off-set by 90° to the pipe connection (in a clockwise direction) | 8) = Dimension for cylinder with seal versions A and B |
| 2) = Ø D4 max. 0.5 mm deep | 9) = Take the minimum stroke length „X* min.“ into account |
| 3) = Throttle valve only with end position damping "E" (180° to the bleed point) | 10) = Dim. „XV“ must always be stated in clear text in the case of an order. Preferred XV dim.: Trunnions located in the middle of the cylinder. Take dims. XVmin and XVmax. into account. |
| 4) = For flange connections see separate table on pages 18 and 19 | 11) = XVmid. recommendation: The trunnions located in the middle of the cylinder |

Foot mounting MS2

CDH3 MS2

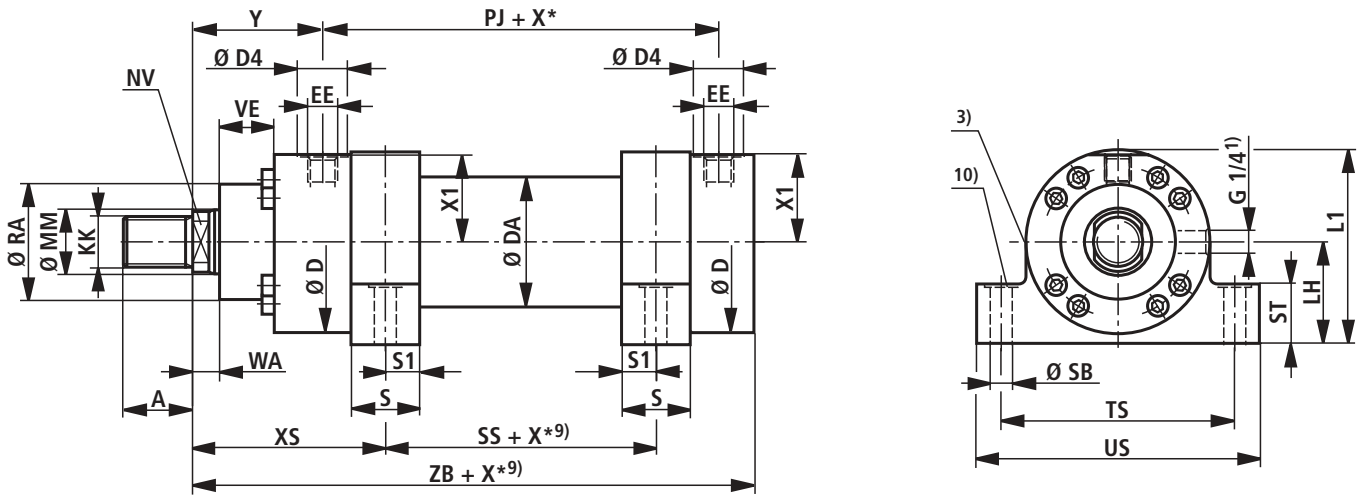

For seal versions „A“, „B“ and AL \emptyset 160 - 320 mm

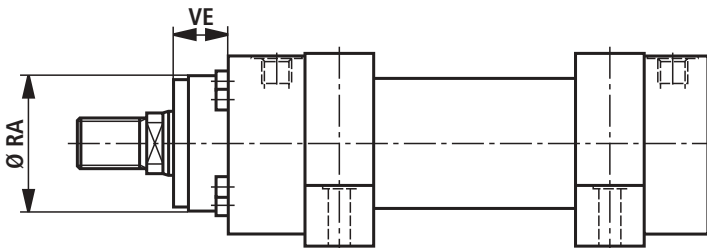

CGH3 MS2

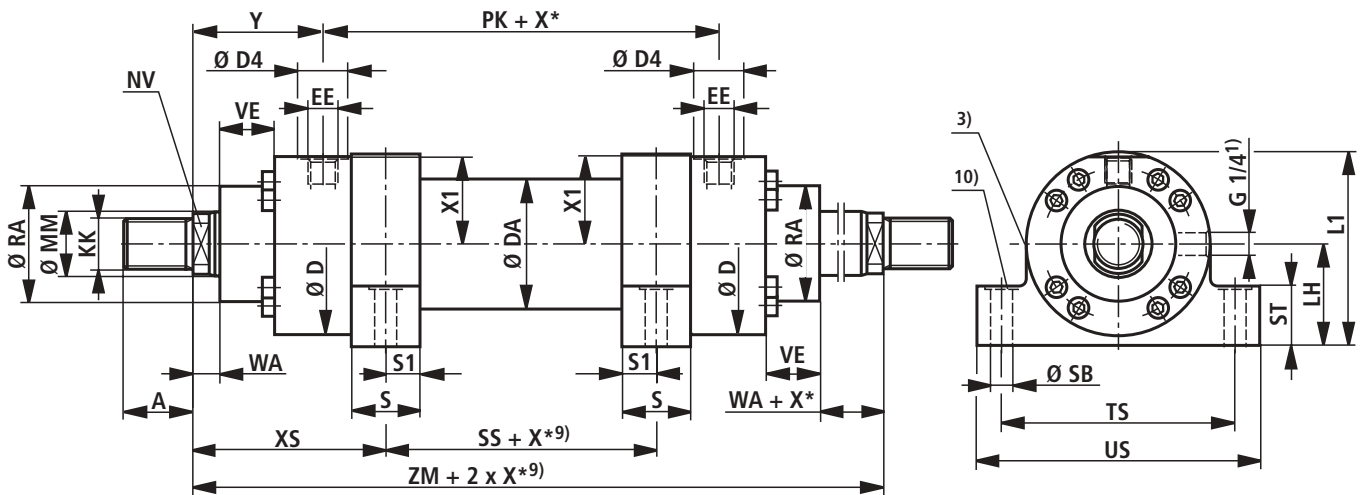

For seal versions „A“, „B“ and AL \emptyset 160 - 320 mm

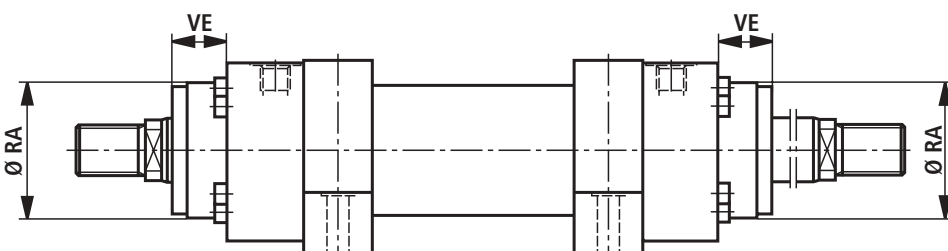

Dimensions MS2 (in mm)

AL Ø	MM Ø	KK 5)	A 5)	KK 6)	A 6)	NV	D	DA	D4 2)	EE 4)	EE 4)	Y	PJ	X1	WA	PK	XS
40	28	M22x1.5	22	M24x2	35	22	92	52	34	G1/2	M22x1.5	91	120	43	18	120	126
50	36	M28x1.5	28	M30x2	45	30	108	62	34	G1/2	M22x1.5	90	120	51.5	18	120	130
63	45	M35x1.5	35	M39x3	55	36	140	78	42	G3/4	M27x2	117	133	67	22	133	164
80	56	M45x1.5	45	M50x3	75	46	148	100	42	G3/4	M27x2	124	146	71.5	22	146	176
100	70	M58x1.5	58	M64x3	95	60	186	125	47	G1	M33x2	119	171	90.5	25	171	179
125	90	M65x1.5	65	M80x3	110	75	235	160	58	G1 1/4	M42x2	170	205	114	32	205	245
140	100	M80x2	80	M90x3	120	85	258	175	58	G1 1/4	M42x2	186	219	126	35	219	265.5
160	110	M100x2	100	M100x3	140	95	292	200	65	G1 1/2	M48x2	210	240	142.5	40	240	302.5
180	125	M110x2	110	M110x4	150	110	325	220	65	G1 1/2	M48x2	241	264	159.5	45	264	353.5
200	140	M120x3	120	M120x4	160	120	350	245	65	G1 1/2	M48x2	262	278	172.5	45	278	379.5
220	160	M120x3	120	M120x4	160	140	375	292	65	G1 1/2	M48x2	262	326	185	40	326	387.5
250	180	M130x3	130	M150x4	190	160	440	324	65	G1 1/2	M48x2	272	336	218	40	336	397.5
280	200	–	–	M160x4	200	180	460	368	65	G1 1/2	M48x2	282	366	228	40	366	410
320	220	–	–	M180x4	220	200	490	406	65	G1 1/2	M48x2	287	391	243	40	391	440

AL Ø	MM Ø	ZB	ZM	SS	X* min.	S	S1	SB H13	ST	TS js13	US -1	LH	L1	RA ⁷⁾ Ø f8	VE ⁷⁾	RA ⁸⁾ Ø f8	VE ⁸⁾
40	28	238	302	50	–	30	15	17.5	32	125	155	50	96	52	45	52	20
50	36	237	300	40	4	40	20	22	37	150	185	60	114	70	47	70	19
63	45	285	367	39	15	50	25	24	47	185	235	75	145	88	43	88	13
80	56	305	394	42	22	60	30	26	52	210	270	80	154	98	53	98	15
100	70	330	409	51	23	70	35	33	62	250	320	100	193	120	55	120	17
125	90	425	545	55	39	90	45	40	72	310	390	120	237.5	150	68	150	20
140	100	457	591	60	39	95	47.5	40	77	340	420	135	267.5	170	75	170	23
160	110	515	660	55	64	115	57.5	45	87	370	450	150	296	200	90	200	90
180	125	565	746	39	110	145	72.5	45	79	415	515	165	327.5	230	100	230	100
200	140	600	802	43	116	155	77.5	52	112	460	570	180	355	250	110	250	110
220	160	655	850	75	100	155	77.5	52	112	500	610	200	387.5	275	125	275	125
250	180	695	880	85	90	155	77.5	52	122	550	660	225	445	320	135	320	135
280	200	735	930	110	70	160	80	62	142	600	720	235	465	335	150	335	150
320	220	775	965	85	400	190	95	74	162	650	780	255	500	350	165	350	165

Notes

AL = Piston Ø

MM = Piston rod Ø

X* = Stroke length

1) = Bleeding: When viewed on the piston rod, the orientation is always off-set by 90° to the pipe connection (in a clockwise direction)

2) = Ø D4 max. 0.5 mm deep

3) = Throttle valve only with end position damping "E" (180° to the bleed point)

4) = For flange connections see separate table on pages 18 and 19

5) = Thread version „G“

6) = Thread version „A“

7) = Dimension for cylinder with seal versions M, T and S

8) = Dimension for cylinder with seal versions A and B

9) = Take the minimum stroke length „X*min.“ into account

10) = 2 mm deep counter bore for the DIN 912 S.H.C.S.: – The screws must not be subjected to shear loads. The forces have to be distributed by keys.

Flange connections

CDH3: AL-Ø 40-320 mm

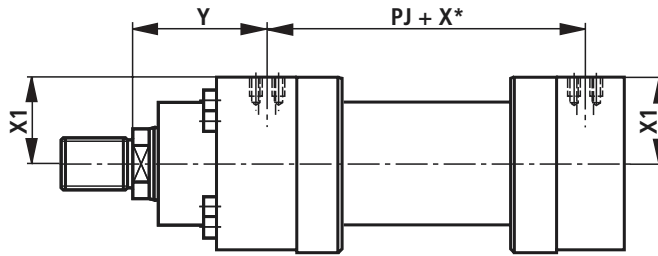

CGH3: AL-Ø 40-320 mm

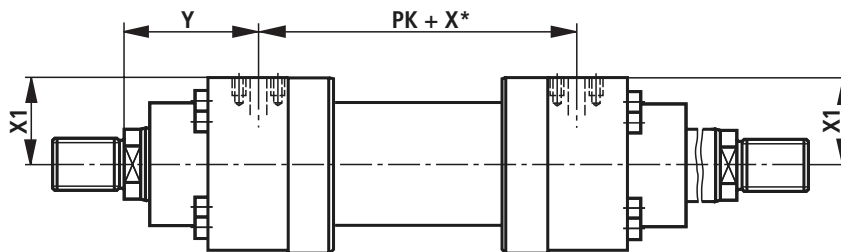

Porting pattern for a rectangular flange to ISO 6162
table 2 (\triangle SAE 6000 PSI)

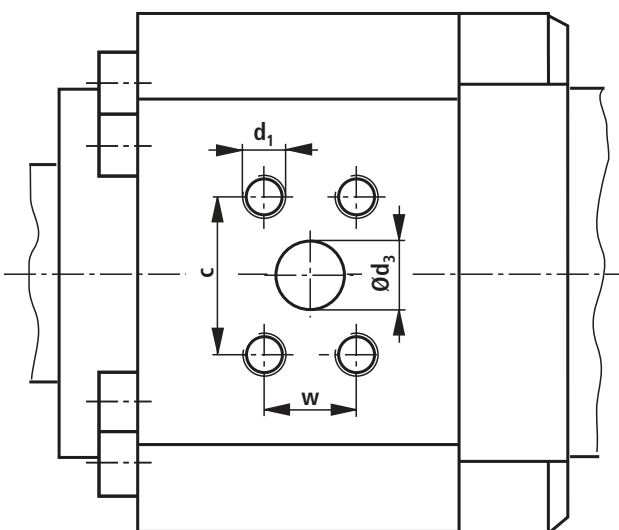

Porting pattern for a square flange to ISO 6164
table 2

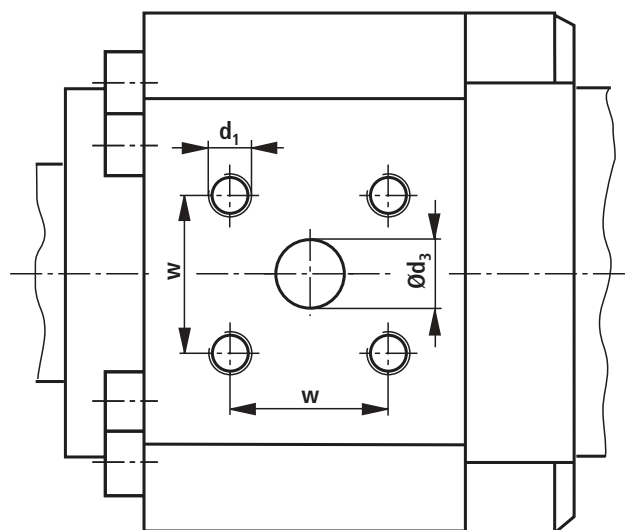

Flange connections

Dimensions (in mm)

AL Ø	ISO 6162 Tab.2 (400 bar) (\triangle SAE 6000 PSI)											ISO 6164 Tab.2 (400 bar)							
	Y	PJ PK	X1	X2	d ₃ Ø	d ₃ ³⁾ Ø	c ±0.25	w ±0.25	d ₁	t ₁ ¹⁾	p ²⁾	Y	PJ PK	X1	d ₃ Ø	w ±0.25	d ₁	t ₁ ¹⁾	p ²⁾
40	–	–	–	–	–	–	–	–	–	–	–	90	122	42.5	10	24.7	M6	12.5	400
50	–	–	–	–	–	–	–	–	–	–	–	89	122	51	10	24.7	M6	12.5	400
63	113	141	65	65	13	1/2"	40.5	18.2	M8	16	400	113	141	66	19	35.4	M8	16	400
80	120	154	69	69	13	1/2"	40.5	18.2	M8	16	400	120	154	70	19	35.4	M8	16	400
100	114	181	87	87	19	3/4"	50.8	23.8	M10	20	400	118	173	89.5	19	35.4	M8	16	400
125	162.5	220	111.5	111.5	25	1"	57.2	27.8	M12	24	400	162.5	220	112.5	32	51.6	M12	24	400
140	179.5	232	121.5	121.5	32	1 1/4"	66.6	31.8	M14	26	400	179.5	232	124.5	32	51.6	M12	24	400
160	197.5	265	139.5	139.5	32	1 1/4"	66.6	31.8	M14	26	400	197.5	265	140.5	38	60.1	M16	30	400
180	233.5	279	156.5	156.5	32	1 1/4"	66.6	31.8	M14	26	400	233.5	279	156.5	38	60.1	M16	30	400
200	254.5	293	167.5	167.5	38	1 1/2"	79.3	36.5	M16	30	400	254.5	293	170.5	38	60.1	M16	30	400
220	262	326	178	178	38	1 1/2"	79.3	36.5	M16	30	400	262	326	182	38	60.1	M16	30	400
250	272	336	212	212	38	1 1/2"	79.3	36.5	M16	30	400	272	336	216	38	60.1	M16	30	400
280	282	366	222	222	38	1 1/2"	79.3	36.5	M16	30	400	282	366	226	38	60.1	M16	30	400
320	287	391	236	236	51	2"	96.8	44.5	M20	36	400	287	391	240	51	69.3	M16	30	400

Notes

For main dimensions see pages 6 to 17

AL = Piston Ø

X* = Stroke length

1) = Thread depth

2) = Max. operating pressure for associated flange in bar

3) = Flange porting pattern to ISO 6162 Tab.2 relates to a flange porting pattern to SAE 6000 PSI

Position measuring system

MP3, MP5: AL-Ø 40-320 mm

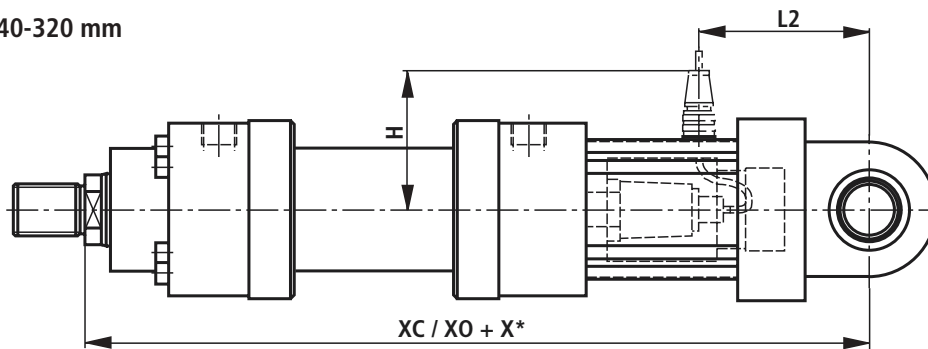

MF3: AL-Ø 40-320 mm

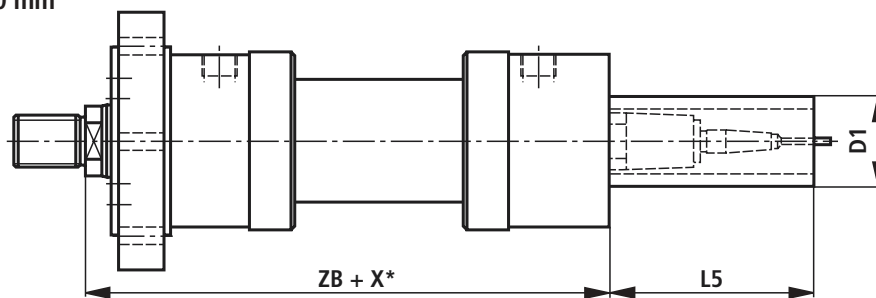

MF4: AL-Ø 40-63 mm

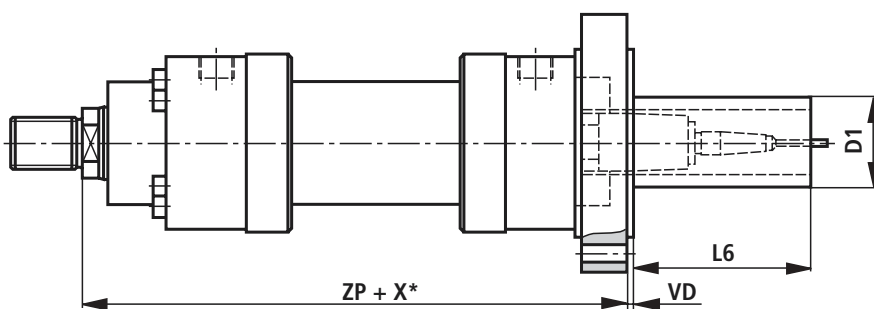

MF4: AL-Ø 80-320 mm

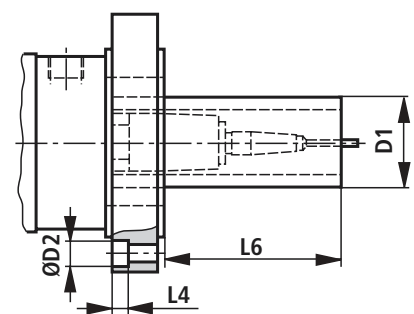

MT4: AL-Ø 40-320 mm

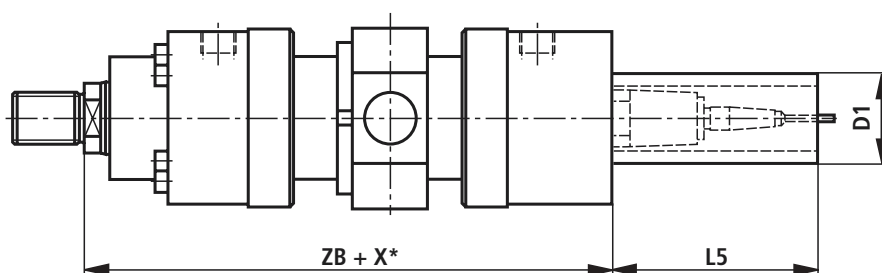

MS2: AL-Ø 40-320 mm

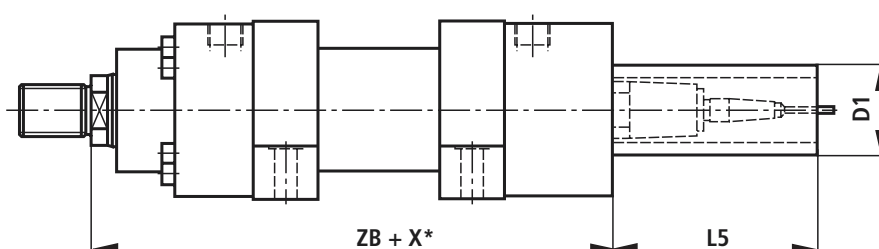

Position measuring system

Dimensions (in mm)

AL Ø	MM Ø	X* max.	XC	XO	H	ZB	ZP	VD	L2	L4	L5	L6	D1 max.	D2 Ø
40	28	1400	433	433	115	247	282	5	102	0	166	166	80	0
50	36	1400	445	445	125	246	285	5	115	0	166	166	94	0
63	45	2000	508	508	140	304	340	5	127	0	166	153	94	0
80	56	2000	540	540	125	332	370	5	137	0	166	123	94	0
100	70	3000	565	565	135	347	402	5	155	0	166	106	94	0
125	90	3000	668	668	150	427	495	5	185	25,5	166	93	94	40
140	100	3000	705	705	160	460	532	10	201	28,5	166	84	94	43
160	110	3000	785	785	170	515	600	10	225	28,5	166	71	94	43
180	125	3000	838	838	180	565	665	10	235	35	166	56	94	53
200	140	3000	888	888	195	600	710	10	245	35	166	46	94	53
220	160	3000	970	970	215	655	770	10	270	38	166	41	94	57
250	180	3000	1055	1055	235	695	820	10	320	44	166	31	94	66
280	200	3000	1115	1115	285	735	865	10	350	44	166	26	94	66
320	220	3000	1195	1195	300	775	915	10	400	44	166	16	94	66

Notes

For main dimensions see pages 6 to 17

AL = Piston Ø

MM = Piston rod Ø

X* = Stroke length

X*_{max} = Max. stroke length

Position measuring system

The contactless, absolute position measuring system is rated up to 500 bar. Its function principle is based on the magnetostrictive effect. In connection with this, a torsion impulse is triggered off when two magnetic fields meet. This impulse is directed from the point of measurement via the waveguide inside the measuring scale to the sensor head. The transit time is constant and virtually independent of temperature. It is proportional to the position of the magnet and can therefore be used as a reference for the actual position value and is converted into a direct analogue or digital output in the sensor head.

Technical data

Operating pressure	bar	350
Analogue output	V	0 to 10
	Load resistance	k Ω \geq 5
	Resolution	Continuous
Analogue output	mA	4 to 20
	Load resistance	k Ω \geq 100
	Resolution	Continuous
Digital output		SSI 24 Bit grey coded
	Resolution	μ m 5
Linearity (absolute accuracy)	%	$\leq \pm 0.05$ (referred to the measuring length)
	mm	min. ± 0.05
Repeatability	%	$\leq \pm 0.001$ (referred to the measuring length)
	mm	min. ± 0.006
Hysteresis	mm	≤ 0.03
Supply voltage	V DC	24 (± 25 % with an analogue output)
	Power consumption	mA 80
	Residual ripple	% s-s ≤ 1
	V DC	24 (+ 20 %/- 15 % with a digital output)
	Power consumption	mA 55
	Residual ripple	% s-s ≤ 1
Protection	Tube and flange	IP 67
	Sensor electronics	IP 65
Operating temperature	Sensor electronics	$^{\circ}$ C - 40 to + 65
	Measuring scale	$^{\circ}$ C - 40 to + 85
Temperature co-efficient	Voltage	ppm/ $^{\circ}$ C 70
	Current	ppm/ $^{\circ}$ C 90

Position measuring system

Mounting styles

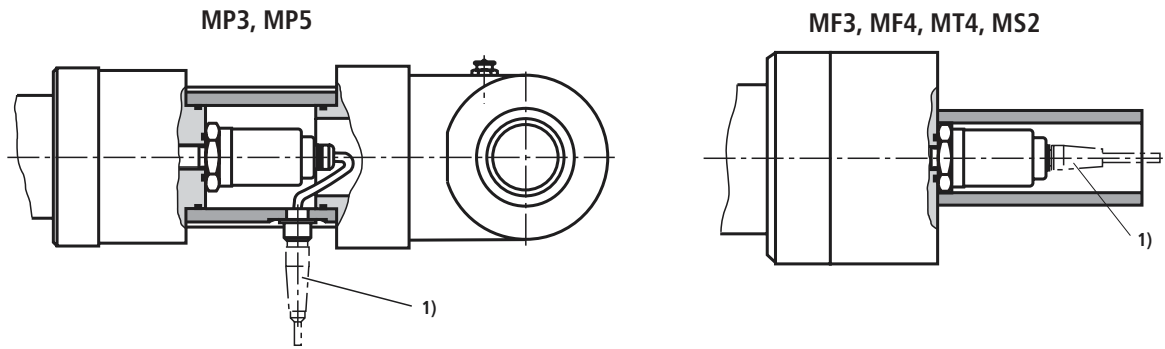

1) For analogue output:
6-pin Amphenol -
Plug-in connector Material No. **R900072231**
(plug-in connector is **not** included within the scope of supply, it must be ordered separately)



1) For digital output:
7-pin Amphenol -
Plug-in connector Material No. **R900079551**
(plug-in connector is **not** included within the scope of supply, it must be ordered separately)



Connection allocation

Position measuring system (analogue output)

Component plug (viewed on the pin side)

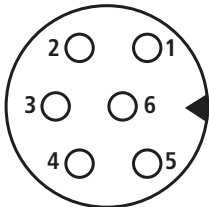

Pin	Cable	Signal / current	Signal / volatge
1	Grey	4...20 mA	0 - 10 V
2	Pink	Gnd	Gnd
3	Yellow	n. c.	10 - 0 V
4	Green	n. c.	Gnd
5	Brown	+24 V DC ($\pm 25\%$)	+24 V DC ($\pm 25\%$)
6	White	Gnd	Gnd

Position measuring system (digital output)

Component plug (viewed on the pin side)

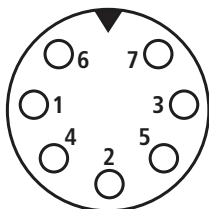

Pin	Cable	Signal / SSi
1	Grey	Data (-)
2	Pink /	Data (+)
3	Yellow	Tact (+)
4	Green	Tact (-)
5	Brown	+24 V DC (+20%/-15%)
6	White	0 V
7	-	n. c.

Proximity switch

CDH3: AL-Ø 40-320 mm

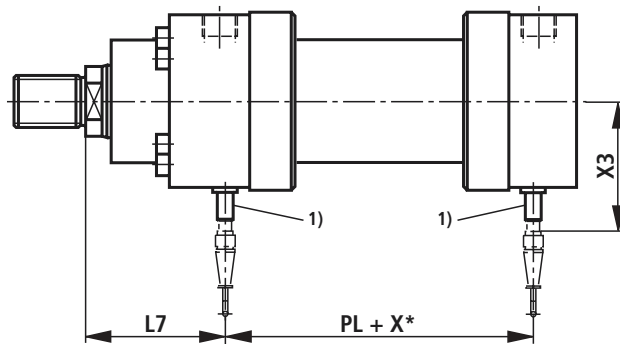

CGH3: AL-Ø 40-320 mm

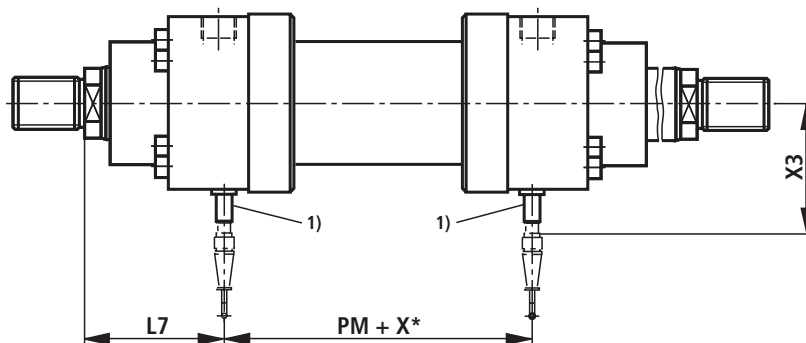

Mounting styles

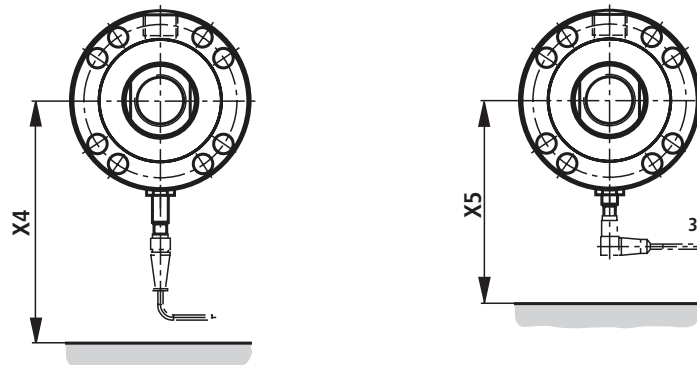

Plug-in connector with a 5m cable

Material No. **R900026512**

(plug-in connector is **not** included within the scope of supply, it must be ordered separately)



Plug-in connector, angled with a 5m cable (the orientation of the cable exit is not definable)

Material No. **R900021404**

(plug-in connector is **not** included within the scope of supply, it must be ordered separately)

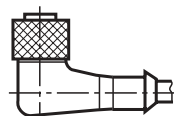

Proximity switch

Dimensions (in mm)

AL Ø	MM Ø	PL	PM	L7	X3	X4	X5
40	28	112	112	95	94	170	125
50	36	110	110	95	98	175	130
63	45	125	125	121	103	180	135
80	56	138	138	128	108	185	140
100	70	161	161	124	116	195	150
125	90	193	193	176	126	205	160
140	100	209	209	191	146	225	180
160	110	228	228	216	151	230	185
180	125	254	254	246	159 ²⁾	235	190
200	140	264	264	269	166 ²⁾	245	200
220	160	310	310	270	177 ²⁾	255	– ³⁾
250	180	320	320	280	187 ²⁾	265	– ³⁾
280	200	360	360	285	199 ²⁾	275	– ³⁾
320	220	375	375	295	209 ²⁾	285	– ³⁾

Notes

For main dimensions see pages 6 to 17

AL = Piston Ø

MM = Piston rod Ø

X* = Stroke length

1) = The proximity switch is always opposite to the pipe connection

2) = Piston Ø 180-320 mm the limit switch does not overhang

3) = Piston Ø 220-320 mm the angled plug-in connector is not possible

Proximity switch

Inductive proximity switches are used as a reliable end position control for hydraulic cylinders. They are an important element, in providing safety systems, interlocks and/or other machine functions where signals safely and exactly monitor the end position. The up to 500 bar rated high pressure proximity switches operates without contact

and contacts are are, therefore wear free. Due to safety reasons the proximity switch is protected against being screwed in too deep. The switching distance can, therefore not be adjusted. As standard the cylinders are fitted with proximity switches on both sides.

Technical data

Function		PNP N/O
Permissible pressure	bar	500
Operating voltage	V DC	10 ... 30
	Including the residual ripple	%
Voltage drop	V	≤ 1.5
Rated operating voltage	V DC	24
Rated operating current	mA	200
No load current	mA	≤ 8
Residual current	µA	≤ 10
Repeatability	%	≤ 5
Hysteresis	%	≤ 15
Ambient temperature range	°C	- 25 ... + 80
Temperature drift	%	≤ 10
Switching frequency	Hz	1000
Protection	Active area	IP 68 to DIN 40050
	Proximity switch	IP 67 to DIN 40050
Housing material		Material No. 1.4104

Connection allocation

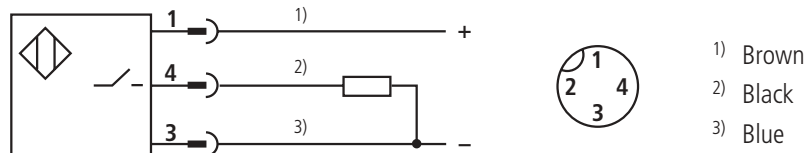

Coupling

Notes

For pressure measurement or bleeding.
For installation in the bleed/measuring port. Coupling with check valve function, i.e. it can also be connected when pressure is present.

Scope of supply:

Coupling AB-E 20-11/K1
with NBR seal Material No. **R900009090**

Coupling AB-E 20-11/K1 V
with FKM seal Material . **R900001264**

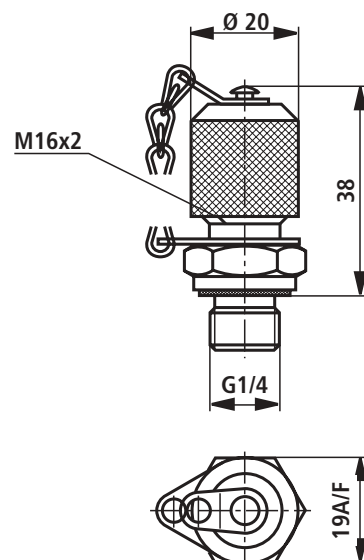

Plain clevis CSA (in mm)

AL-Ø 40-200 mm

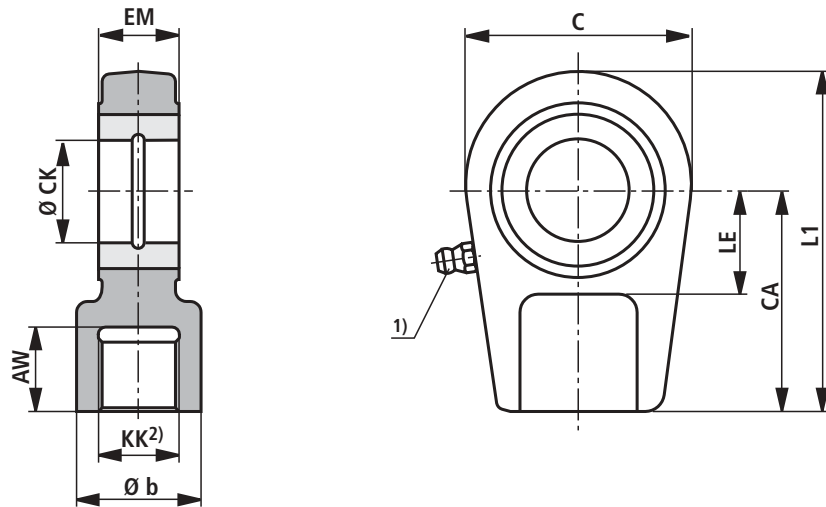

AL Ø	Type	Material No.	AW	b	C	CA	CK H11	EM -0.4	KK	LE	L1	$m^3)$ kg
40	CSA 22	R900303151	23	34	64	60	30	28	M22x1.5	30	94	0.7
50	CSA 28	R900303152	29	44	78	70	35	30	M28x1.5	40	112	1.1
63	CSA 35	R900303153	36	55	94	85	40	35	M35x1.5	45	135	2.0
80	CSA 45	R900303154	46	70	116	105	50	40	M45x1.5	55	168	3.3
100	CSA 58	R900303155	59	87	130	130	60	60	M58x1.5	65	200	5.5
125	CSA 65	R900303156	66	93	154	150	70	55	M65x1.5	75	232	8.6
140	CSA 80	R900303157	81	125	176	170	80	60	M80x2	80	265	12.2
160	CSA100	R900303158	101	143	206	210	90	65	M100x2	90	323	21.5
180	CSA110	R900303159	111	153	230	235	100	70	M110x2	105	360	27.5
200	CSA120	R900303160	125	176	265	265	110	80	M120x2	115	407.5	40.7

Notes

AL = Piston Ø

1) = Grease nipple; cone head form A to DIN 71 412

2) = The plain clevis must always be screwed on up to the piston rod thread stop

3) m = Weight of the plain clevis

Self-aligning clevis CGA (in mm)

AL-Ø 40-250 mm

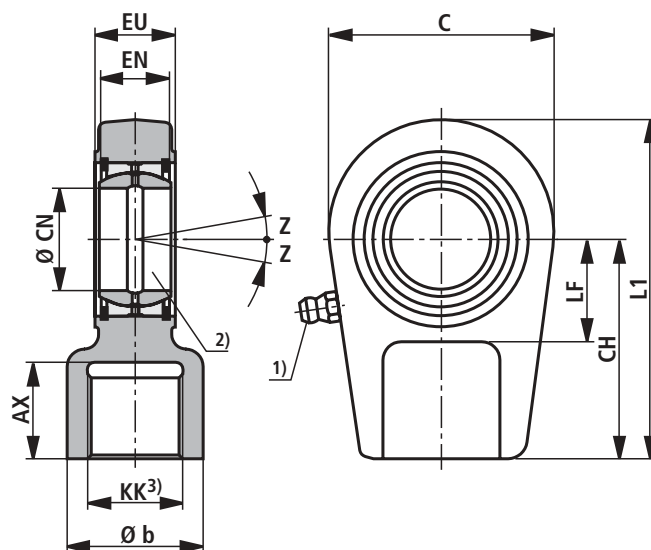

AL Ø	Type	Material No.	AX	b	C	CH	CN	EN	EU -0.4	KK	L1	LF	Z	$m^{4)}$ kg
40	CGA 22	R900303126	23	34	64	60	30 _{-0.010}	22 _{-0.12}	28	M22x1.5	94	30	7°	0.7
50	CGA 28	R900303127	29	44	78	70	35 _{-0.012}	25 _{-0.12}	30	M28x1.5	112	40	7°	1.1
63	CGA 35	R900303128	36	55	94	85	40 _{-0.012}	28 _{-0.12}	35	M35x1.5	135	45	7°	2.0
80	CGA 45	R900303129	46	70	116	105	50 _{-0.012}	35 _{-0.12}	40	M45x1.5	168	55	7°	3.3
100	CGA 58	R900303130	59	87	130	130	60 _{-0.015}	44 _{-0.15}	50	M58x1.5	200	65	7°	5.5
125	CGA 65	R900303131	66	93	154	150	70 _{-0.015}	49 _{-0.15}	55	M65x1.5	232	75	6°	8.6
140	CGA 80	R900303132	81	125	176	170	80 _{-0.015}	55 _{-0.15}	60	M80x2	265	80	6°	12.2
160	CGA100	R900303133	101	143	206	210	90 _{-0.020}	60 _{-0.20}	65	M100x2	323	90	6°	21.5
180	CGA110	R900303134	111	153	230	235	100 _{-0.020}	70 _{-0.20}	70	M110x2	360	105	7°	27.5
200	CGA120	R900303135	125	176	265	265	110 _{-0.020}	70 _{-0.20}	80	M120x3	407,5	115	6°	40.7
220	CGA120	R900303135	125	176	265	265	110 _{-0.020}	70 _{-0.20}	80	M120x3	407,5	115	6°	40.7
250	CGA130	R900303136	135	188	340	310	120 _{-0.020}	85 _{-0.20}	90	M130x3	490	140	6°	76.4
280	—	—	—	—	—	—	—	—	—	—	—	—	—	—
320	—	—	—	—	—	—	—	—	—	—	—	—	—	—

Notes

AL = Piston Ø

1) = Grease nipple; cone head form A to DIN 71 412

2) = Associated pin Ø m6;

Associated pin Ø j6 with a maintenance free self-aligning clevis

3) = The self-aligning clevis must always be screwed on up to the piston rod thread stop

4) m = Weight of the self-aligning clevis

5) = Flanged grease nipple DIN 3404-A

For piston Ø 360 to 500 mm as standard

Self-aligning clevis CGAK (in mm)

AL-Ø 40-250 mm

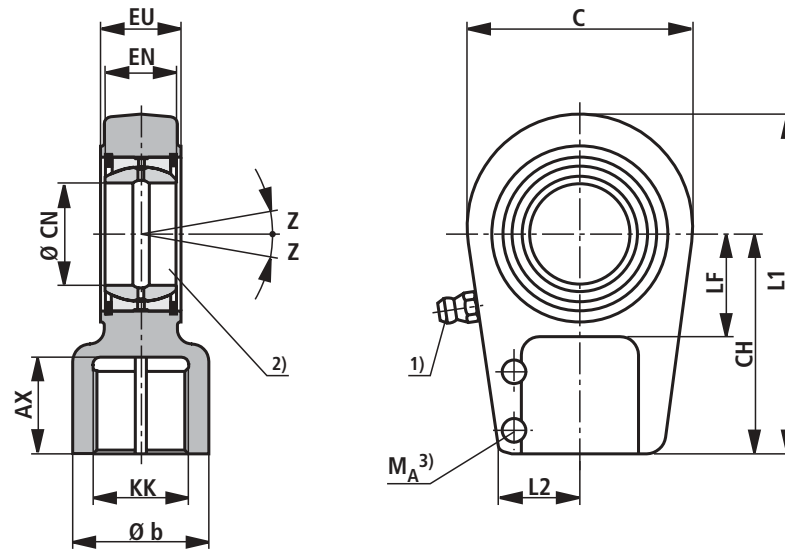

AL Ø	Type	Material No.	AX	b	C	CH	CN	EN	EU -0.4	KK	L1	L2	LF	$M_A^{3)}$ Nm	Z	$m^{4)}$ kg
40	CGAK 22	R900303163	23	34	64	60	30 _{-0.010}	22 _{-0.12}	28	M22x1.5	94	22	30	20	7°	0.7
50	CGAK 28	R900303164	29	44	78	70	35 _{-0.012}	25 _{-0.12}	30	M28x1.5	112	27	40	20	7°	1.1
63	CGAK 35	R900303165	36	55	94	85	40 _{-0.012}	28 _{-0.12}	35	M35x1.5	135	35	45	40	7°	2.0
80	CGAK 45	R900303166	46	70	116	105	50 _{-0.012}	35 _{-0.12}	40	M45x1.5	168	42	55	80	7°	3.3
100	CGAK 58	R900303167	59	87	130	130	60 _{-0.015}	44 _{-0.15}	50	M58x1.5	200	54	65	160	7°	5.5
125	CGAK 65	R900303168	66	93	154	150	70 _{-0.015}	49 _{-0.15}	55	M65x1.5	232	57	75	160	6°	8.6
140	CGAK 80	R900303169	81	125	176	170	80 _{-0.015}	55 _{-0.15}	60	M80x2	265	66	80	160	6°	12.2
160	CGAK100	R900321655	101	143	206	210	90 _{-0.020}	60 _{-0.20}	65	M100x2	323	76	90	160	6°	21.5
180	CGAK110	R900321691	111	153	230	235	100 _{-0.020}	70 _{-0.20}	70	M110x2	360	85	105	300	7°	27.5
200	CGAK120	R900321621	125	176	265	265	110 _{-0.020}	70 _{-0.20}	80	M120x3	407.5	96	115	500	6°	40.7
220	CGAK120	R900321621	125	176	265	265	110 _{-0.020}	70 _{-0.20}	80	M120x3	407.5	96	115	500	6°	40.7
250	CGAK130	R900322015	135	188	340	310	120 _{-0.020}	85 _{-0.20}	90	M130x3	490	112	140	1000	6°	76.4
280	-	-	-	-	-	-	-	-	-	-	-	-	-	-	-	-
320	-	-	-	-	-	-	-	-	-	-	-	-	-	-	-	-

Notes

AL = Piston Ø

1) = Grease nipple; cone head form A to DIN 71 412

2) = Associated pin Ø m6
Associated pin Ø j6 with a maintenance free self-aligning clevis

3) M_A = Tightening torque

The self-aligning clevis must always be screwed on up to the piston rod thread stop. Subsequently, the clamping screws have to be tightened to the specified torque.

4) m = Weight of the self-aligning clevis

Self-aligning clevis CGAS (in mm)

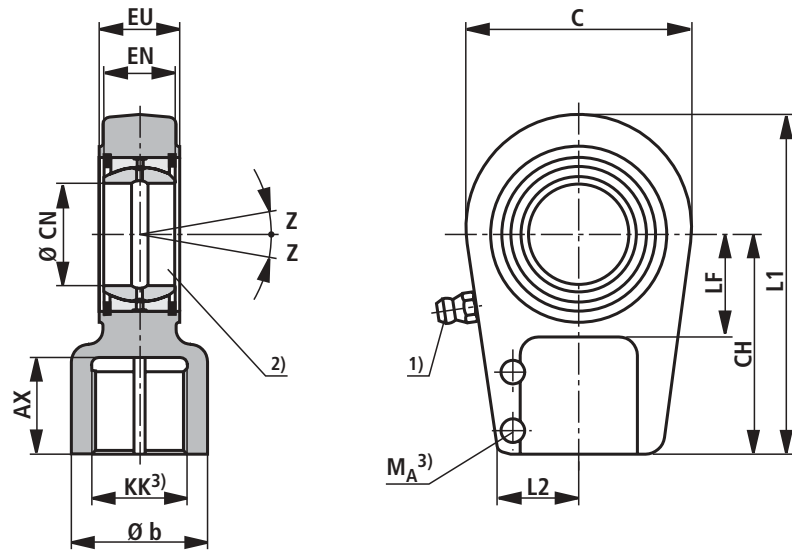

AL Ø	Type	Material No.	AX	b	C	CH	CN	EN	EU -0.4	KK	L1	L2	LF	$M_A^{3)}$ Nm	Z	$m^{4)}$ kg
40	CGAS 30	R900303138	35	34	64	75	30 _{-0.010}	22 _{-0.12}	28	M24x2	109	27	30	20	7°	1.0
50	CGAS 35	R900303139	45	44	78	90	35 _{-0.012}	25 _{-0.12}	30	M30x2	132	33	40	40	7°	1.3
63	CGAS 40	R900303140	55	55	94	105	40 _{-0.012}	28 _{-0.12}	35	M39x3	155	39	45	80	7°	2.4
80	CGAS 50	R900303141	75	70	116	135	50 _{-0.012}	35 _{-0.12}	40	M50x3	198	45	55	80	7°	4.1
100	CGAS 60	R900303142	95	87	130	170	60 _{-0.015}	44 _{-0.15}	50	M64x3	240	59	65	160	7°	6.5
125	CGAS 70	R900303143	110	105	154	195	70 _{-0.015}	49 _{-0.15}	55	M80x3	278	65	75	160	6°	9.5
140	CGAS 80	R900303144	120	125	176	210	80 _{-0.015}	55 _{-0.15}	60	M90x3	305	76	80	300	6°	16
160	CGAS 90	R900303145	140	150	206	250	90 _{-0.020}	60 _{-0.20}	65	M100x3	363	81	90	300	5°	28
180	CGAS100	R900303146	150	170	230	275	100 _{-0.020}	70 _{-0.20}	70	M110x4	400	86	105	300	7°	34
200	CGAS110	R900303147	160	180	264	300	110 _{-0.020}	70 _{-0.20}	80	M120x4	442.5	97	115	500	6°	44
220	CGAS110	R900303147	160	180	265	300	110 _{-0.020}	70 _{-0.20}	80	M120x4	442.5	97	115	500	6°	44
250	CGAS120	R900303148	190	210	340	360	120 _{-0.020}	85 _{-0.20}	90	M150x4	540	112	140	500	6°	75
280	CGAS140	R900317314	200	230	380	420	140 _{-0.025}	90 _{-0.25}	110	M160x4	620	123	185	1000	7°	160
320	CGAS160	R900303149	220	260	480	460	160 _{-0.025}	105 _{-0.25}	110	M180x4	710	138	200	1000	8°	235

Notes

AL = Piston Ø

1) = Grease nipple; cone head form A to DIN 71 412

2) = Associated pin Ø m6;
associated pin Ø j6 with a maintenance free self-aligning clevis

3) M_A = Tightening torque
The self-aligning clevis must always be screwed on up to the piston rod thread stop. Subsequently, the clamping screws have to be tightened to the specified torque.

4) m = Weight of the self-aligning clevis

Buckling

The permissible stroke with a flexibly guided load and 3.5 safety factor against buckling can be obtained from the appropriate table. With a deviating cylinder installation orientation the permissible stroke has to be interpolated. Permissible stroke lengths for non-guided loads are available on request.

The calculation for buckling are carried out as follows:

1. Calculation according to Euler

$$F = \frac{\pi^2 \cdot E \cdot I}{\nu \cdot L_K^2} \text{ if } \lambda > \lambda_g$$

2. Calculation according to Tetmajer

$$F = \frac{d^2 \cdot \pi (335 - 0,62 \cdot \lambda)}{4 \cdot \nu} \text{ if } \lambda \leq \lambda_g$$

Explanation:

E = Modulus of elasticity in N/mm²

= 2.1 x 10⁵ for steel

I = Moment of inertia in mm⁴ for circular cross-sectional area

$$= \frac{d^4 \cdot \pi}{64} = 0,0491 \cdot d^4$$

ν = 3.5 (safety factor)

L_K = Free buckling length in mm (dependent on mounting style, see sketches A, B, C)

d = Piston rod Ø in mm

λ = Slenderness ratio

$$= \frac{4 \cdot L_K}{d} \quad \lambda_g = \pi \sqrt{\frac{E}{0.8 \cdot R_e}}$$

R_e = Yield strength of the piston rod material

The influence of the mounting style on the buckling length:

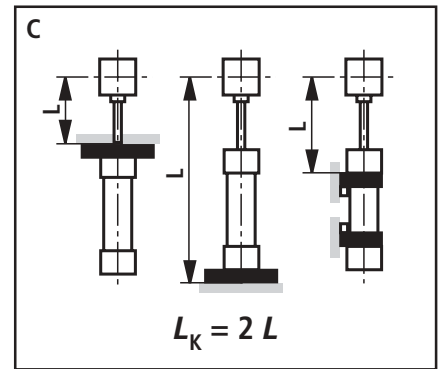
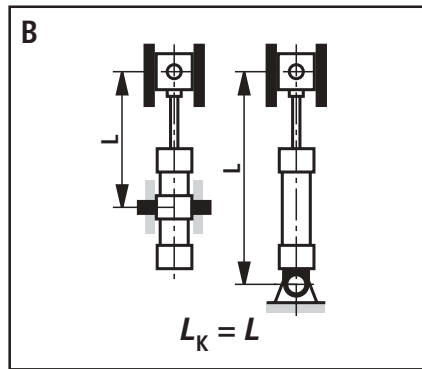
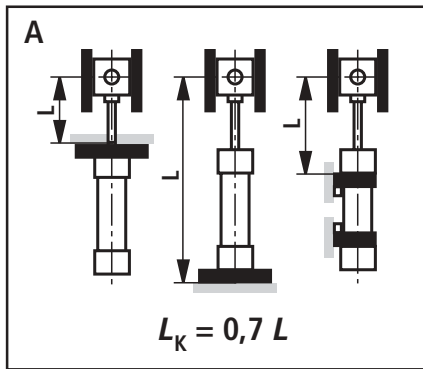

Permissible stroke lengths (in mm)

Mounting styles: MP3, MP5

AL Ø	MM Ø	Permissible stroke at									Max. available stroke	
		100 bar			210 bar			350 bar				
		0°	45°	90°	0°	45°	90°	0°	45°	90°		
40	28	360	375	420	225	230	240	140	145	150	2000	Installation
50	36	505	525	351	335	340	355	230	235	240		
63	45	625	650	755	425	430	455	295	300	305		
80	56	765	800	945	530	545	575	375	380	390	3000	
100	70	950	995	1200	680	695	745	495	500	515		
125	90	1200	1270	1610	895	925	1010	665	680	705		
140	100	1335	1405	1785	995	1025	1125	745	755	790		
160	110	1380	1406	1865	1025	1055	1160	755	770	805	6000	
180	125	1580	1670	2150	1180	1220	1350	880	895	940		
200	140	1780	1890	2470	1355	1400	1565	1035	1055	1110		
220	160	1985	2110	2970	1575	1640	1900	1230	1260	1360		
250	180	2190	2340	3310	1740	1820	2120	1370	1400	1510		
280	200	2360	2520	3640	1890	1970	2330	1490	1530	1660		
320	220	2530	2700	3830	2010	2100	2450	1320	1460	1740		

Permissible stroke lengths (in mm)

Mounting style: MF3

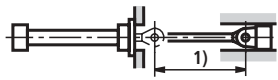
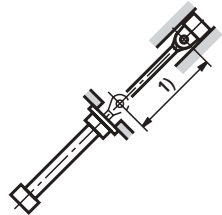
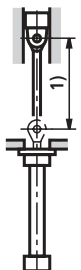
AL Ø	MM Ø	Permissible stroke at									Max. available stroke	
		100 bar			210 bar			350 bar				
		0°	45°	90°	0°	45°	90°	0°	45°	90°		
40	28	1370	1415	1600	1020	1035	1075	795	800	810	2000	Installation 0° 
50	36	1755	1825	2135	1345	1370	1440	1060	1070	1090		
63	45	2000	2000	2000	1660	1695	1800	1320	1330	1365		
80	56	2000	2000	2000	2000	2000	2000	1600	1620	1665	3000	45° 
100	70	3000	3000	3000	2470	2530	2740	1900	2010	2085		
125	90	3000	3000	3000	3000	3000	3000	2615	2660	2785		
140	100	3000	3000	3000	3000	3000	3000	2875	2920	3000		
160	110	3000	3000	3000	3000	3000	3000	2775	3000	3000		
180	125	3000	3000	3000	3000	3000	3000	3000	3000	3000	6000	90°  1) Perm. stroke
200	140	3000	3000	3000	3000	3000	3000	3000	3000	3000		
220	160	6000	6000	6000	5410	5630	6000	4575	4675	5055		
250	180	6000	6000	6000	5950	6000	6000	4815	5160	5605		
280	200	6000	6000	6000	6000	6000	6000	5005	5565	6000		
320	220	6000	6000	6000	6000	6000	6000	4560	5060	6000		

Mounting style: MF4

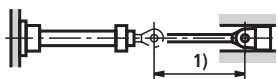
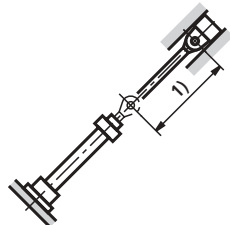
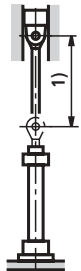

AL Ø	MM Ø	Permissible stroke at									Max. available stroke	
		100 bar			210 bar			350 bar				
		0°	45°	90°	0°	45°	90°	0°	45°	90°		
40	28	540	565	675	380	385	410	270	275	280	2000	Installation 0° 
50	36	735	770	940	540	550	590	400	405	415		
63	45	900	945	1175	670	690	745	505	510	530		
80	56	1080	1140	1450	825	845	930	630	635	665	3000	45° 
100	70	1330	1400	1840	1030	1070	1190	805	820	860		
125	90	1655	1760	2450	1330	1380	1590	1060	1080	1160		
140	100	1830	1940	2700	1470	1530	1760	1175	1200	1285		
160	110	1905	2030	2830	1530	1590	1835	1035	1160	1300		
180	125	2210	2355	3310	1795	1870	2170	1285	1435	1585	6000	90°  1) Perm.stroke
200	140	2400	2565	3000	1965	2050	2420	1410	1590	1765		
220	160	2655	2850	4445	2245	2360	2935	1735	1930	2160		
250	180	2945	3160	4950	2490	2620	3275	1840	2095	2410		
280	200	3170	3410	5455	2705	2850	3615	1870	2140	2665		
320	220	3425	3680	5775	2905	3055	3820	1675	1925	2815		

Permissible stroke lengths (in mm)

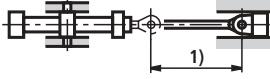
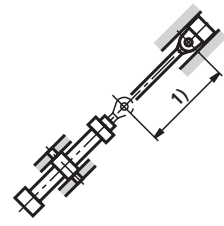
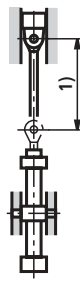
Mounting style: MT4 (the trunnions are located in the middle of the cylinder)

AL Ø	MM Ø	Permissible stroke at									Max. available stroke	
		100 bar			210 bar			350 bar				
		0°	45°	90°	0°	45°	90°	0°	45°	90°		
40	28	560	580	640	380	385	395	265	270	275	2000	Installation 0° 
50	36	760	790	890	353	545	565	390	395	400		
63	45	930	965	1105	665	675	705	490	495	505		
80	56	1125	1170	1365	815	830	875	610	615	625	3000	45° 
100	70	1390	1450	1730	1030	1050	1120	785	790	810		
125	90	1755	1845	2300	1345	1380	1500	1040	1050	1090		
140	100	1935	2030	2545	1485	1525	1660	1150	1165	1210		
160	110	2020	2125	2660	1545	1585	1725	1190	1205	1250		
180	125	2300	2420	3000	1770	1820	1990	1370	1390	1445		
200	140	2555	2695	3000	1990	2050	2270	1555	1580	1655	6000	90°  1) Perm. stroke
220	160	2870	3045	4185	2320	2410	2760	1865	1905	2035		
250	180	3180	3380	4665	2580	2680	3080	2080	2125	2270		
280	200	3430	3645	5130	2800	2915	3390	2270	2325	2500		
320	220	3700	3925	5435	3000	3115	3585	2065	2295	2640		

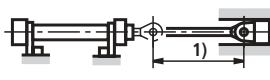
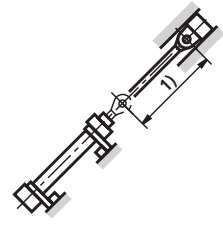
Mounting style: MS2

AL Ø	MM Ø	Permissible stroke at									Max. available stroke	
		100 bar			210 bar			350 bar				
		0°	45°	90°	0°	45°	90°	0°	45°	90°		
40	28	1265	1310	1500	920	935	970	690	695	710	2000	Installation 0° 
50	36	1650	1715	2000	1235	1260	1330	950	960	980		
63	45	1995	2000	2000	1520	1550	1655	1180	1190	1220		
80	56	2000	2000	2000	1850	1895	2000	1445	1460	1510	3000	45° 
100	70	2940	3000	3000	2310	2370	2585	1830	1855	1925		
125	90	3000	3000	3000	3000	3000	3000	2640	2685	2810		
140	100	3000	3000	3000	3000	3000	3000	2640	2690	2840		
160	110	3000	3000	3000	3000	3000	3000	2510	2760	2955		
180	125	3000	3000	3000	3000	3000	3000	2900	3000	3000		
200	140	3000	3000	3000	3000	3000	3000	3000	3000	3000	6000	90°  1) Perm. stroke
220	160	6000	6000	6000	5065	5280	6000	4225	4330	4705		
250	180	6000	6000	6000	5590	5835	6000	4455	4805	5250		
280	200	6000	6000	6000	6000	6000	6000	4645	5205	5790		
320	220	6000	6000	6000	6000	6000	6000	4175	4680	6000		

End position cushioning

Self-adjusting end position cushioning

The objective is to reduce the speed of a moving mass, whose centre of gravity lies on the cylinder axis, to a level, at which neither the cylinder nor the machine, into which the cylinder is installed, can be damaged.

The self-adjusting end position cushioning produces a controlled deceleration in both end positions (braking). The effective cushioning length adjusts automatically to the current requirements.

The calculation depends on the factors of weight, velocity, system pressure and installation position. Therefore, the variable D_m is to be calculated from weight and speed, the variable D_p from system pressure and installation position. These variables are then used to verify the permissible cushioning performance in the "cushioning capacity" diagram. The intersection point of the variables D_m and D_p must always be below the cushioning capacity curve of the selected cylinder.

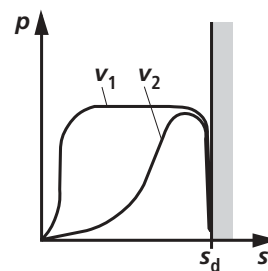
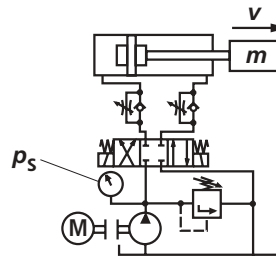

Formulas:

$$D_m = \frac{m}{10^k} ; \quad K = kv (0.5 - v)$$

m = Moved mass in kg

v = Stroke velocity in m/s

kv = See table on page 32

Extending:

$$D_p = p_s - \frac{m \cdot 9,81 \cdot \sin \alpha}{A_1 \cdot 10}$$

Retracting:

$$D_p = p_s + \frac{m \cdot 9,81 \cdot \sin \alpha}{A_3 \cdot 10}$$

p_s = System pressure in bar

A_1 = Piston area in cm^2 (see page 2)

A_3 = Annulus area in cm^2 (see page 2)

α = Angle in degrees with reference to the horizontal plane

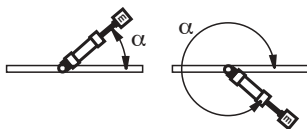
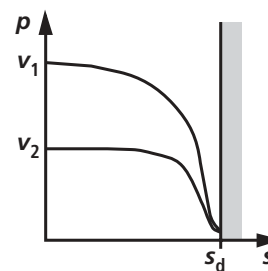

Damping length

AL Ø mm	40	50	63	80	100	125	140	160	180	200	220	250	280	320
Head side	21	20	23	25	25	25	33	33	37	37	76	81	86	90
Base side	21	20	23	25	25	25	33	33	37	37	76	81	86	90

End position cushioning

AL Ø mm	40	50	63	80	100	125	140	160	180	200	220	250	280	320
kv ①	1.72	1.85	1.51	1.85	2.34	2.02	1.85	1.93	1.84	1.65	1.41	1.45	1.58	1.68
kv ②	2.31	1.85	1.95	1.86	2.25	1.97	1.94	1.92	2.05	1.97	1.64	1.61	1.82	1.94

Cushioning capacity: Extending

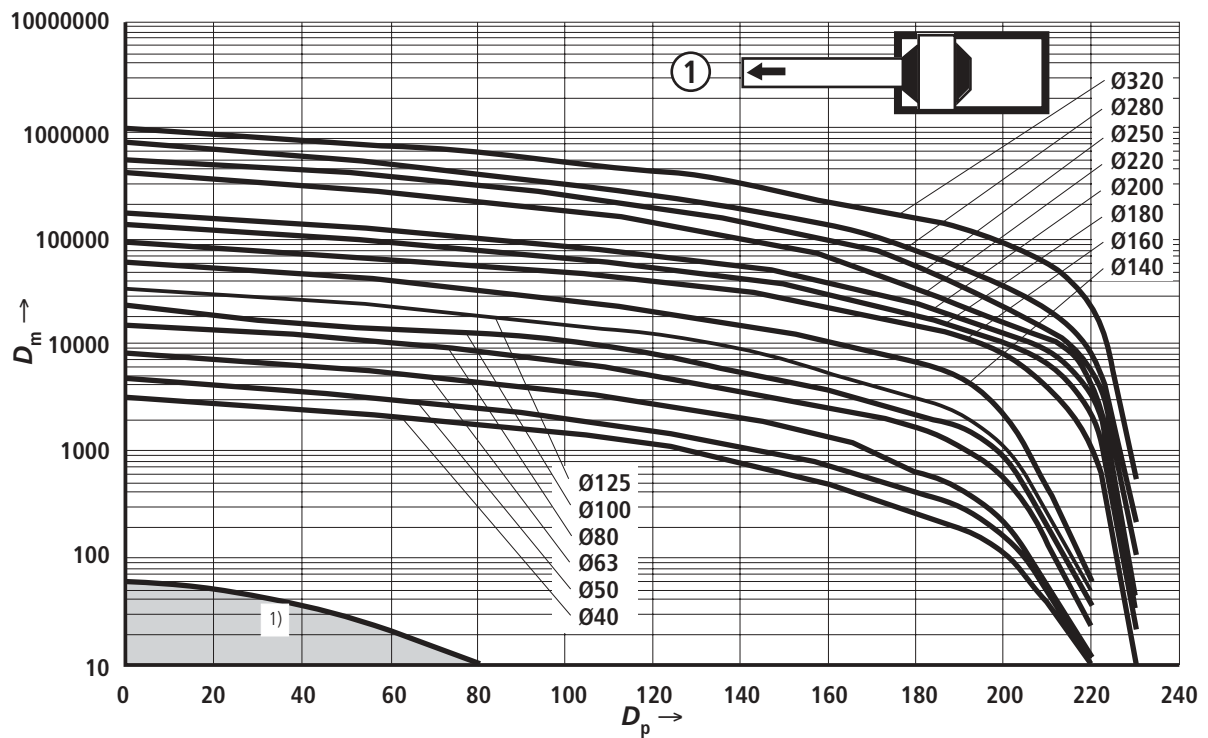

Notes

AL = Piston Ø

1) If, for standard applications, the calculated section point from D_m and D_p is within the indicated area, then we recommend that a cylinder is used without end position damping.

End position cushioning

Cushioning capacity: Retracting

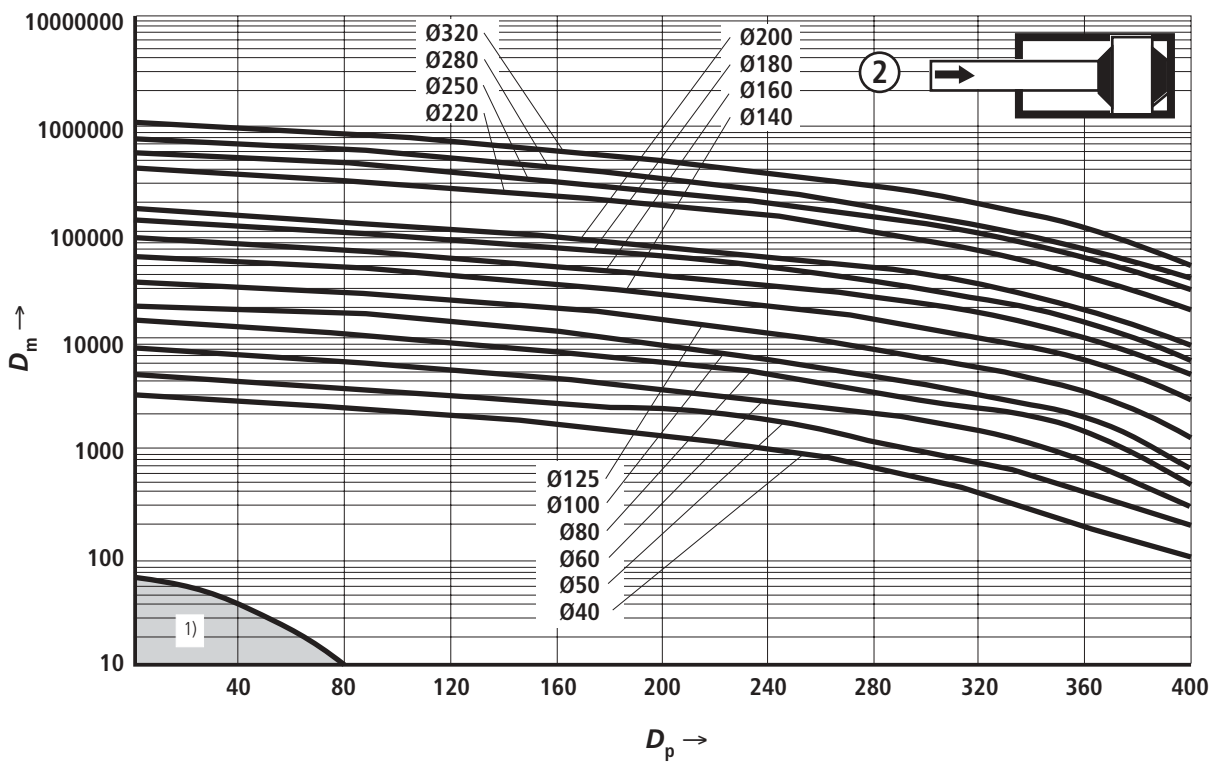

Notes

- 1) If, for standard applications, the calculated section point from D_m and D_p is within the indicated area, then we recommend that a cylinder is used without end position damping.

Spare parts

CDH3

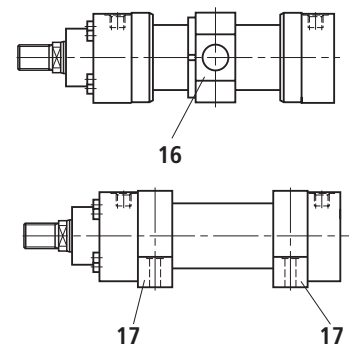
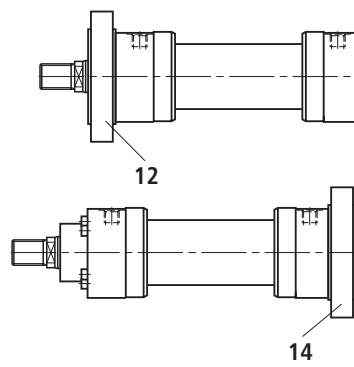
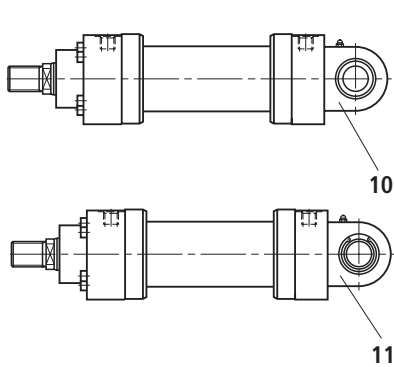
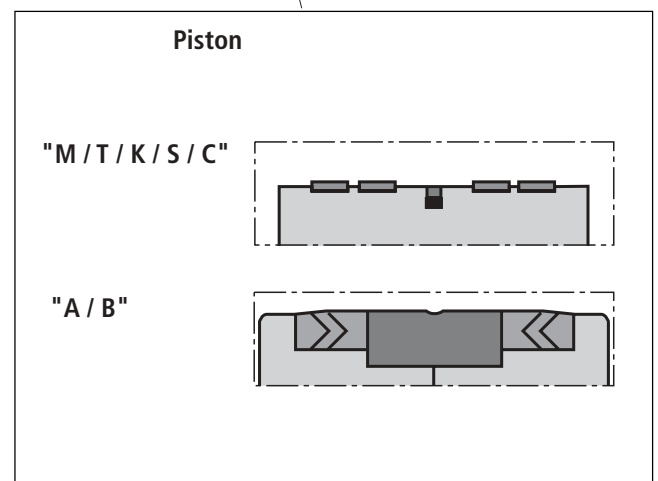
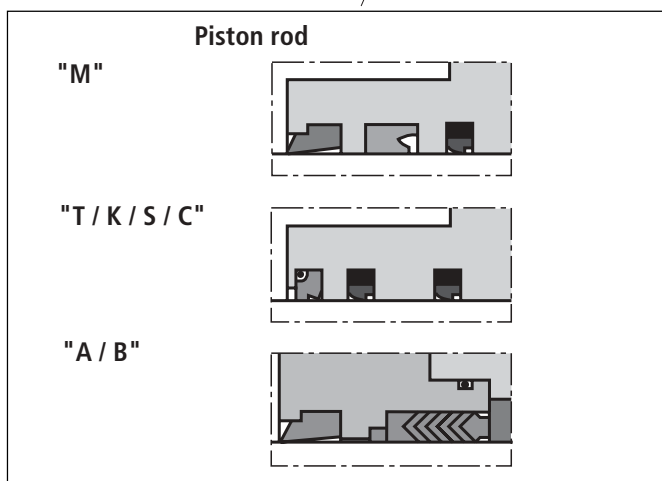
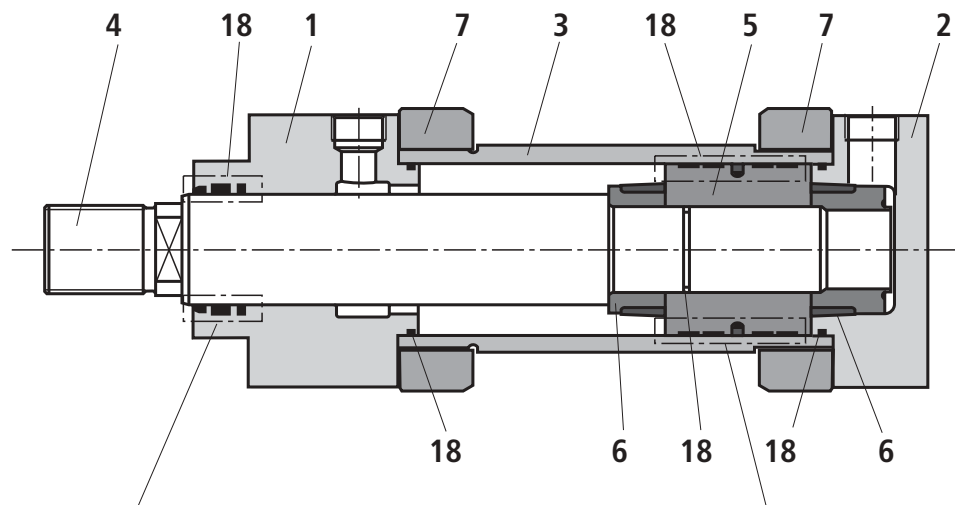

- 1 Head
- 2 Base
- 3 Barrel
- 4 Piston rod
- 5 Piston
- 6 Damping bush
- 7 Flange
- 10 Base MP3
- 11 Base MP5
- 12 Round flange MF3

- 14 Round flange MF4
- 16 Trunnion MT4
- 17 Foot MS2
- 18 Seal kit:
 - Wiper
 - Rod seal
 - Piston seal
 - O-ring
 - Guide bush

Spare parts

CGH3

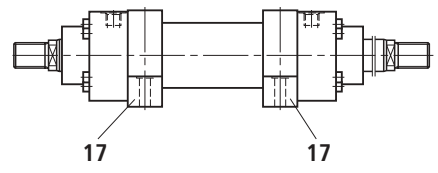
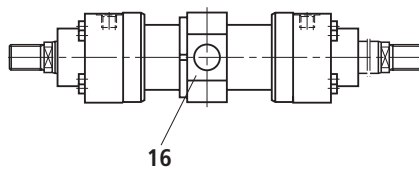
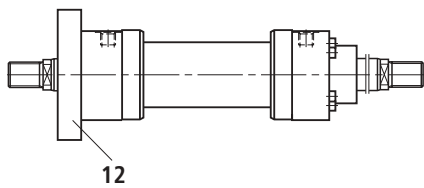
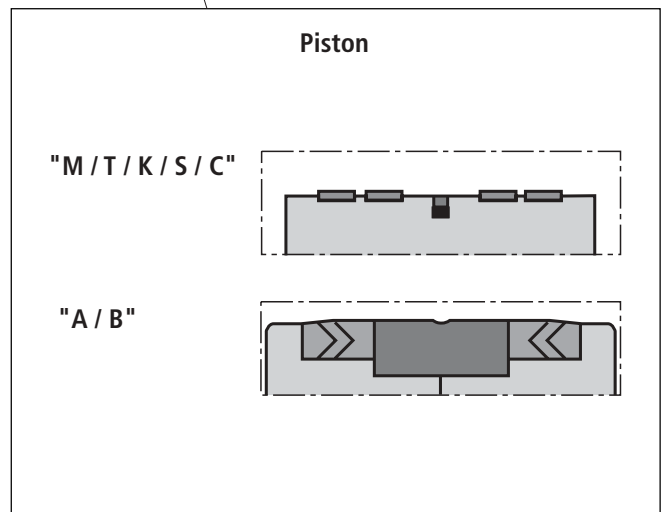
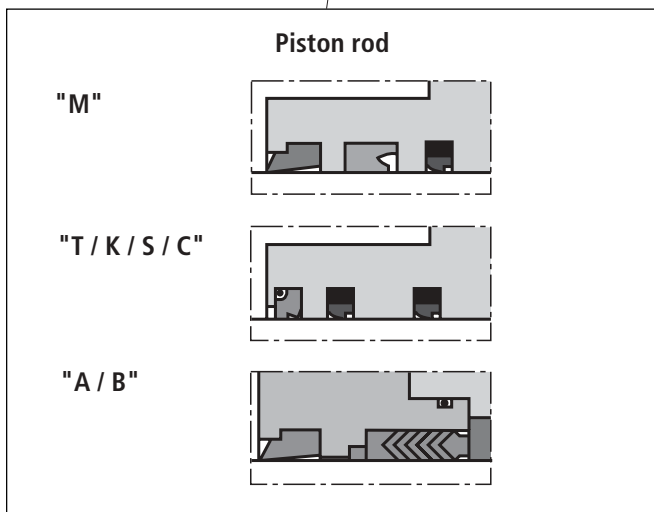
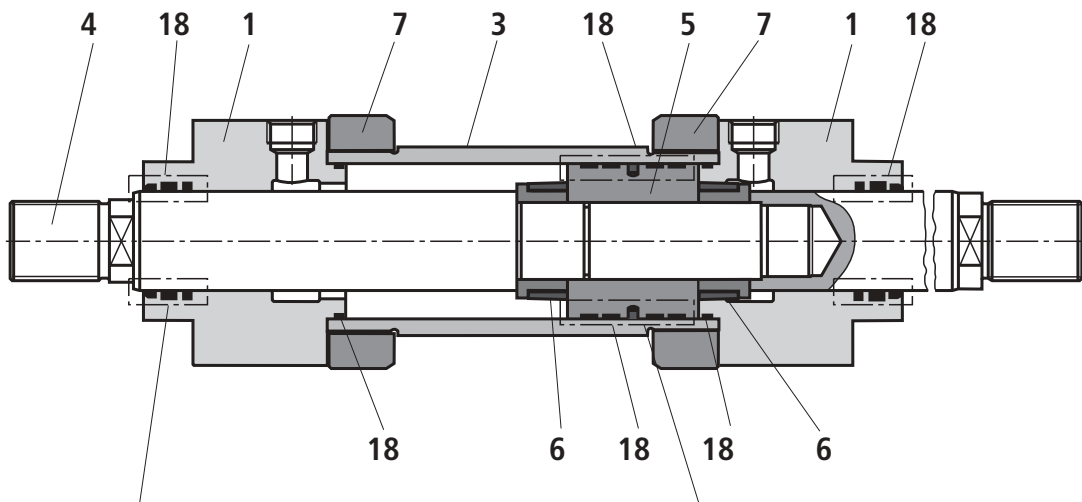

- 1 Head
- 3 Barrel
- 4 Piston rod
- 5 Piston
- 6 Damping bush
- 7 Flange
- 12 Round flange MF3
- 16 Trunnion MT4
- 17 Foot MS2
- 18 Seal kit:
 - Wiper
 - Rod seal
 - Piston seal
 - O-ring
 - Guide bush

Tightening torques

Screws: Head and base (Pos. 1 and 2)

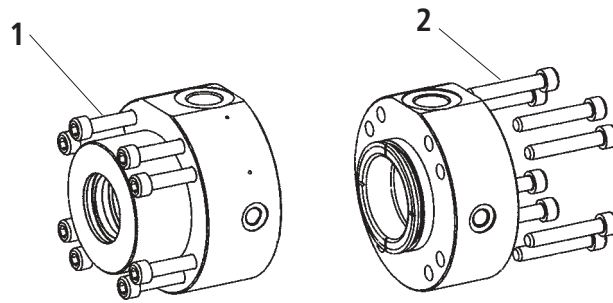

Series	Piston Ø	Screw	Quantity	Grade	Tightening torque
CDH3 / CGH3	40	M10	4	10.9	40 Nm
CDH3 / CGH3	50	M8	8	10.9	25 Nm
CDH3 / CGH3	63	M10	8	10.9	50 Nm
CDH3 / CGH3	80	M12	8	10.9	90 Nm
CDH3 / CGH3	100	M16	8	10.9	175 Nm
CDH3 / CGH3	125	M20	8	10.9	350 Nm
CDH3 / CGH3	140	M20	8	10.9	450 Nm
CDH3 / CGH3	160	M24	8	10.9	670 Nm
CDH3 / CGH3	180	M24	12	10.9	580 Nm
CDH3 / CGH3	200	M24	12	10.9	720 Nm
CDH3 / CGH3	220	M24	16	10.9	750 Nm
CDH3 / CGH3	250	M30	16	10.9	1400 Nm
CDH3 / CGH3	280	M30	16	10.9	1600 Nm
CDH3 / CGH3	320	M42	12	10.9	4200 Nm

Screws: Seal cover (Pos. 3)

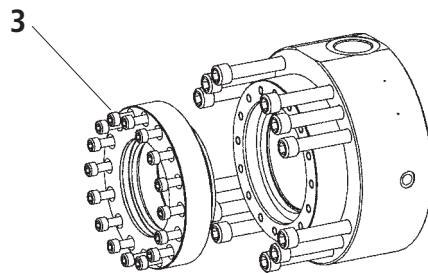

Series	Piston Ø	Piston rod Ø	Screw	Quantity	Grade	Tightening torque
CDH3 / CGH3	160	110	M10	16	10.9	60 Nm
CDH3 / CGH3	180	125	M12	16	10.9	80 Nm
CDH3 / CGH3	200	140	M12	16	10.9	90 Nm
CDH3 / CGH3	220	160	M12	24	10.9	90 Nm
CDH3 / CGH3	250	180	M16	16	10.9	90 Nm
CDH3 / CGH3	280	200	M16	16	10.9	230 Nm
CDH3 / CGH3	320	220	M16	24	10.9	230 Nm

Seal kits¹⁾

CDH3 – Standard

AL Ø	MM Ø	Material No. Seal version				
		M	T	A	S	B
40	28	R900851087	R900858841	R900859445	R900861001	R900859770
50	36	R900849392	R900860277	R900851515	R900861004	R900860940
63	45	R900847956	R900847855	R900851638	R900861007	R900859678
80	56	R900850905	R900856180	R900854718	R900861010	R900851205
100	70	R900853382	R900860285	R900856094	R900861013	R900860946
125	90	R900857949	R900856102	R900856095	R900861016	R900855464
140	100	R900853965	R900860290	R900856096	R900849080	R900860952
160	110	R900851146	R900857536	R900860933	R900861019	R900860954
180	125	R900848603	R900860292	R900860935	R900861021	R900860956
200	140	R900856431	R900860293	R900860937	R900861023	R900860958
220	160	R900888101	R900888109	R900888117	R900888133	R900888141
250	180	R900888103	R900888111	R900888119	R900888135	R900888143
280	200	R900888105	R900888113	R900888121	R900888137	R900888145
320	220	R900888107	R900888115	R900888123	R900888139	R900888147

Notes

AL = Piston Ø

MM = Piston rod Ø

¹⁾ = Seal kits for position measuring systems and proximity switches have separate Material Nos.

Seal kits¹⁾

CGH3 – Standard

AL Ø	MM Ø	Material No. Seal version				
		M	T	A	S	B
40	28	R900867252	R900868889	R900866747	R900868943	R900867133
50	36	R900864930	R900868892	R900866750	R900868946	R900867136
63	45	R900867262	R900868895	R900866753	R900868949	R900867139
80	56	R900867265	R900868898	R900866756	R900868952	R900867142
100	70	R900867268	R900868901	R900866759	R900868955	R900867146
125	90	R900867270	R900868904	R900866762	R900868957	R900867149
140	100	R900867272	R900868906	R900866764	R900868959	R900867151
160	110	R900867274	R900868908	R900866766	R900868961	R900867153
180	125	R900867276	R900868910	R900866768	R900868963	R900867155
200	140	R900867278	R900868912	R900866770	R900868965	R900867157
220	160	R900888021	R900888029	R900888037	R900888053	R900888061
250	180	R900888023	R900888031	R900888039	R900888055	R900888063
280	200	R900888025	R900888033	R900888041	R900888057	R900888065
320	220	R900888027	R900888035	R900888043	R900888059	R900888067

Notes

AL = Piston Ø

MM = Piston rod Ø

¹⁾ = Seal kits for proximity switches have separate Material Nos.

Seal kits¹⁾

CDH3 – Standard + Option F

AL Ø	MM Ø	Material No. Seal version		
		M+F	T+F	S+F
40	28	R900861025	R900861050	R900861100
50	36	R900861028	R900861053	R900861103
63	45	R900861031	R900861056	R900861106
80	56	R900861034	R900861059	R900861109
100	70	R900861037	R900861062	R900861115
125	90	R900861040	R900861065	R900861122
140	100	R900861042	R900861067	R900861126
160	110	R900861044	R900861069	R900861130
180	125	R900861046	R900861071	R900861135
200	140	R900861048	R900861073	R900861143

CGH3 – Standard + Option F

AL Ø	MM Ø	Material No. Seal version		
		M+F	T+F	S+F
40	28	R900868999	R900869026	R900869093
50	36	R900869002	R900869029	R900869096
63	45	R900869005	R900869032	R900869099
80	56	R900869008	R900869035	R900869102
100	70	R900869013	R900869038	R900869105
125	90	R900869016	R900869041	R900869108
140	100	R900869018	R900869043	R900869110
160	110	R900869020	R900869045	R900869112
180	125	R900869022	R900869047	R900869114
200	140	R900869024	R900869049	R900869116

Notes

AL = Piston Ø

MM = Piston rod Ø

¹⁾ = Seal kits for proximity switches have separate Material Nos.

Seal kits

Position measuring system

AL Ø	Material No. Seal version				
	M / M+F	T / T+F	A	S / S+F	B
40	R900885935		–	R900885937	–
50	R900894958		–	R900894979	–
63	R900894959		–	R900894980	–
80	R900894960		–	R900894981	–
100	R900894961		–	R900894982	–
125	R900894962		–	R900894983	–
140	R900894963		–	R900894985	–
160	R900894964		–	R900894986	–
180	R900894973		–	R900894987	–
200	R900894974		–	R900894988	–
220	R900894975		–	R900894989	–
250	R900894976		–	R900894991	–
280	R900894977		–	R900894993	–
320	R900894978		–	R900894994	–

Proximity switch

AL Ø	Material No. Seal version				
	M / M+F	T / T+F	A	S / S+F	B
40 - 200		R900885938		R900885939	
220 - 320		R900894997		R900894998	

Note

AL = Piston Ø

The data specified above only serves to describe the product. No statements concerning a certain condition or suitability for a certain application can be derived from our information.

The details stated do not release you from the responsibility for carrying out your own assessment and verification. It must be remembered that our products are subject to a natural process of wear and ageing.

Bosch Rexroth AG
Industrial Hydraulics

D-97813 Lohr am Main
Zum Eisengießer 1 • D-97816 Lohr am Main
Telefon 0 93 52 / 18-0
Telefax 0 93 52 / 18-23 58 • Telex 6 89 418-0
eMail documentation@boschrexroth.de
Internet www.boschrexroth.de

Bosch Rexroth SA

BP 37 – Z.I. Les Fourmis
F-74131 Bonneville Cedex
Tel. +33(0)4 50 25 35 45
Fax +33(0)4 50 25 35 19
Internet www.boschrexroth.fr

Bosch Rexroth Teknik AB

Varuvägen 7, Älvsjö
S-125 81 Stockholm
Tel. (08) 72 79 20 0
Fax (08) 86 87 21
eMail cyl.hyd@boschrexroth.se
Internet www.boschrexroth.se
