

**RE 10 335/11.02**

Replaces: 11.97

**Fixed displacement vane pumps  
Types PVV and PVQ**

Nominal sizes 18 to 193

Series 1X

Maximum operating pressure 210 bar

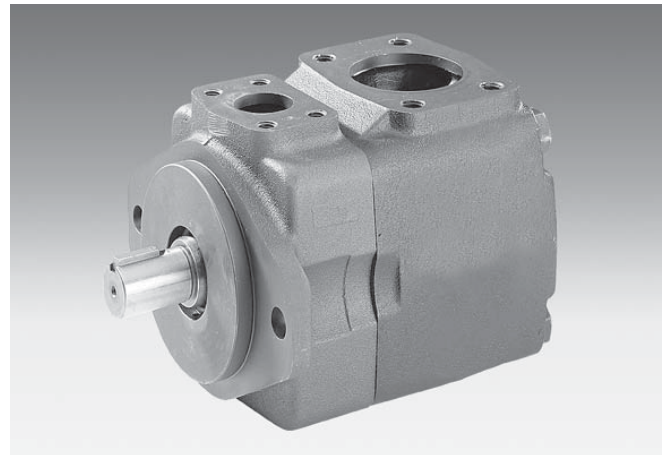
Maximum displacement 18 to 193 cm<sup>3</sup>

H/A/D 5769/97

Single pump type PVV2-1X/...A15D..

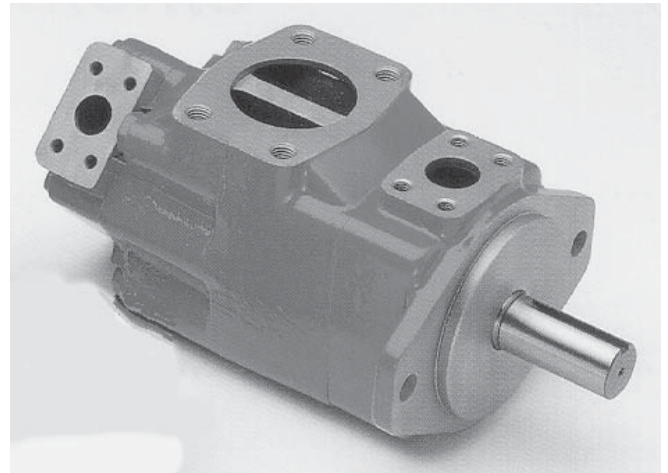

Double pump type PVV21-1X/...A15DD..

**Overview of contents**

Contents	Page
Features	1
Function, section	2; 3
Symbols	3
Ordering details	4
Technical data	5
Drive torque, noise pressure level	6
Drive power	7
Flow, flow losses	8
Unit dimensions:	
• PVV / PVQ 1	9
• PVV / PVQ 2; 4; 5	10
• PVV / PVQ 2...K..	11
• PVV / PVQ 4...K..	12
• PVV / PVQ 5...K..	13
• PVV / PVQ 21; 41; 42; 51; 52	14
• PVV / PVQ 54	15
Pump cartridge	16
Accessories	17
Engineering and commissioning guidelines	18
Installation guidelines	19

**Features**

- Fixed displacement
- Long bearing life due to hydraulically unloaded shaft
- Low wear due to hydraulically unloaded vanes
- Low operating noise
- Easy to service due to exchangable pump cartridges
- Good efficiency
- Optional positioning of the pressure connection
- Clockwise or anti-clockwise direction of rotation
- Drive shaft optionally cylindrical or splined
- Double pump:
  - Very compact design
  - The position of the pressure connections is separately selectable



© 2002

by Bosch Rexroth AG, Industrial Hydraulics, D-97813 Lohr am Main

All rights reserved. No part of this document may be reproduced or stored, processed, duplicated or circulated using electronic systems, in any form or by means, without the prior written authorisation of Bosch Rexroth AG. In the event of contravention of the above provisions, the contravening party is obliged to pay compensation.

This document was prepared with the greatest of care, and all statements have been examined for correctness. This document is subject to alterations for reason of the continuing further developments of products. No liability can be accepted for any incorrect or incomplete statements.

## Function, section

The PVV and PVQ hydraulic pumps are fixed displacement vane pumps.

The rotor (2) is fitted on to the splines of the drive shaft (1) which rotates inside the stator ring (3). The vanes (4) are fitted into slots in the rotor and are pressed onto the inner surface of the stator ring by centrifugal force as the rotor turns. The displacement chambers are sealed on the sides by the control plates (5). Due to the double extentric form of the stator ring there are two pressure and two suction chambers opposite to each other. The drive shaft is thereby

hydraulically unloaded. It only has to carry the torque forces. The vanes are partially unloaded as they pass through the suction areas. This unloading results in reduction in wear and makes it possible to obtain a high efficiency.

By simply removing the cover (6) it is possible to remove the pump cartridge (comprising of rotor, vanes, stator ring and control plates) without having to remove the housing (7) from the pump mounting bracket. This makes it possible to quickly repair and maintain the pump.

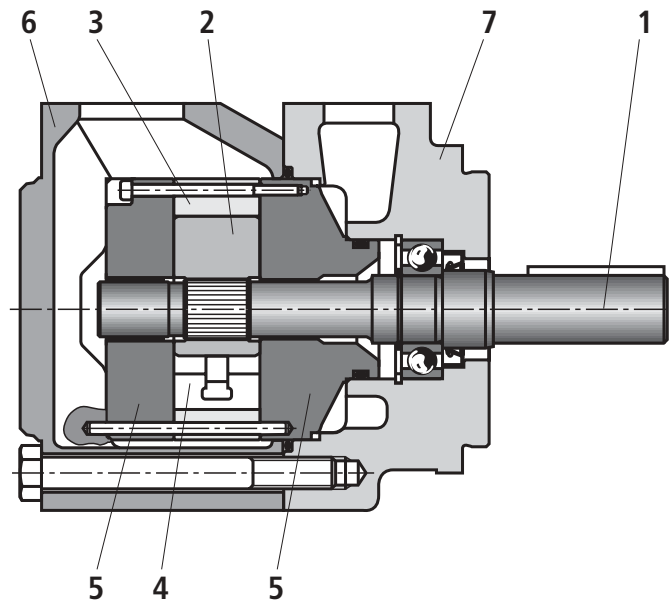
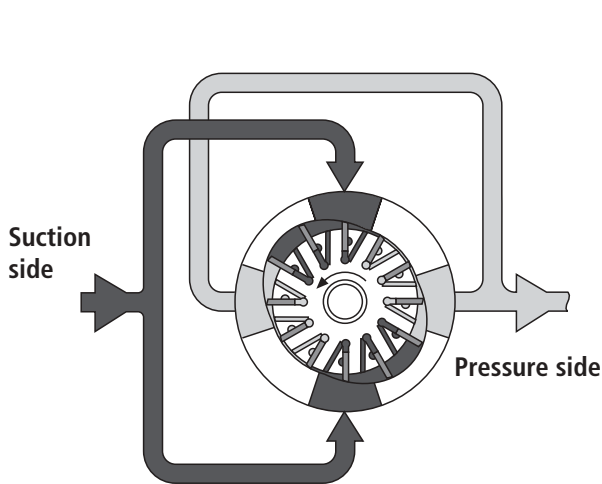

Type PVV..-1X/...A15D...

The design of the type PVQ pump makes it particularly suitable for mobile applications.

The special design of the control plates makes it possible to compensate for the heat expansion of the rotor and to act against sudden pressure changes. Due to the division of the control plates

(7) into flexible discs and the cover plates (8), counter pressure chambers (9) are created that are balanced against the pressures that are in the displacement chambers. Due to this, the optimum clearance between the rotor and the flexible discs is guaranteed and thus the best volumetric efficiency is made possible.

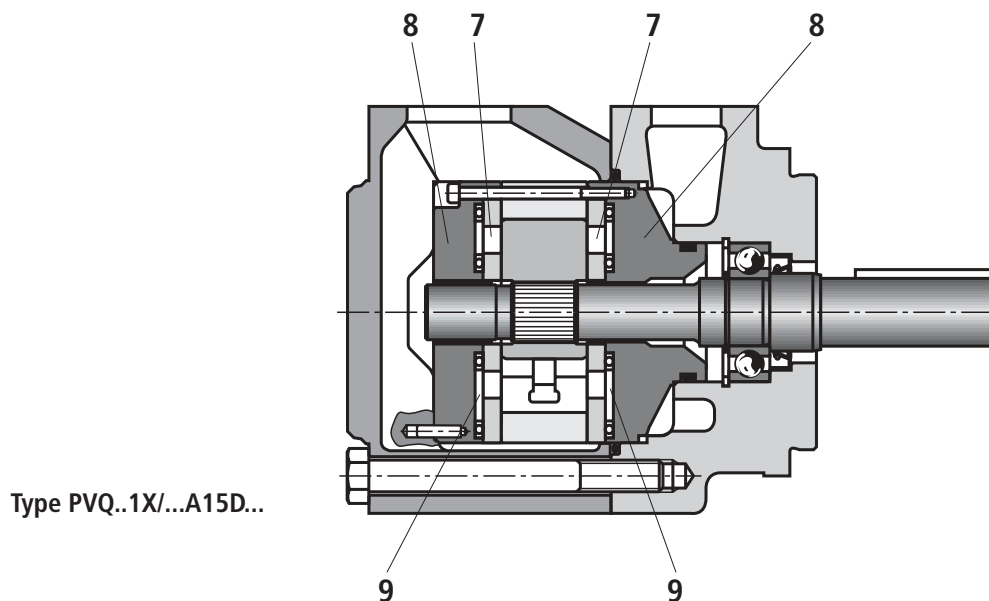

Type PVQ..1X/...A15D...

## Function, section

---

The PVV and PVQ double pumps are created by fitting a second pump cartridge onto a mutual shaft. The oil inlet is via a common suction connection in the centre housing (10). The oil outputs is separate via the pump cartridges. The pressure connection for the front pump cartridge is in the flange housing and for the rear pump cartridge

in the cover plate.

The largest pump cartridge is always fitted at the flange housing end. It is not possible to have identically sized pump cartridges as a double pump.

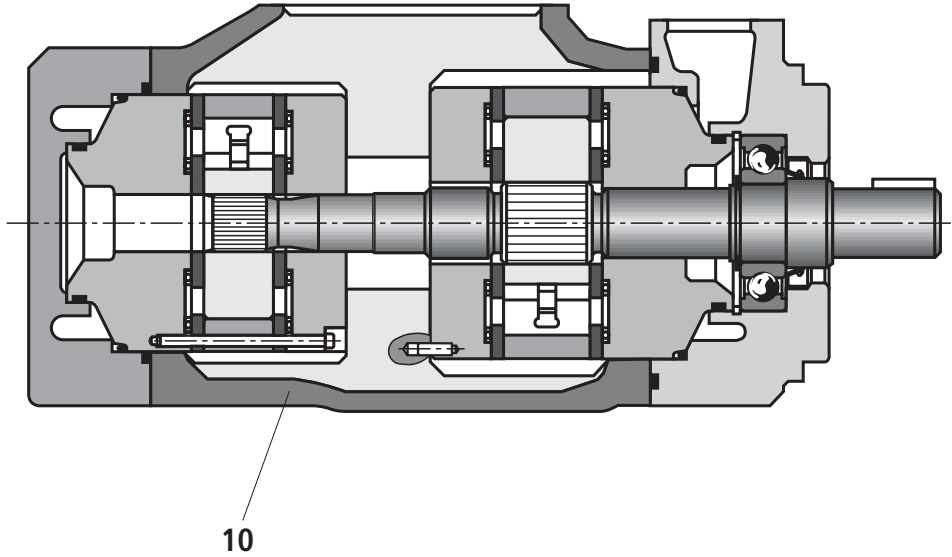

## Symbols

---

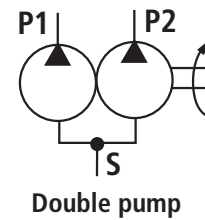
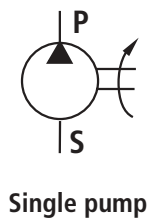

## Ordering details

Single pumps		Double pumps				Single pumps with through drive	
Build size	Displacement	Build size	Flange side	Cover side	Build size	Displacement	
			Displacement	Displacement			
1	18.0 cm <sup>3</sup> = 018	21	40.1 cm <sup>3</sup> = 040	18.0 cm <sup>3</sup> = 018	2	40.1 cm <sup>3</sup> = 040	
	27.4 cm <sup>3</sup> = 027		45.4 cm <sup>3</sup> = 045	27.4 cm <sup>3</sup> = 027		45.4 cm <sup>3</sup> = 045	
	36.4 cm <sup>3</sup> = 036		55.2 cm <sup>3</sup> = 055	36.4 cm <sup>3</sup> = 036		55.2 cm <sup>3</sup> = 055	
	39.5 cm <sup>3</sup> = 040		60.0 cm <sup>3</sup> = 060	39.5 cm <sup>3</sup> = 040		60.0 cm <sup>3</sup> = 060	
	45.9 cm <sup>3</sup> = 046		67.5 cm <sup>3</sup> = 068	45.9 cm <sup>3</sup> = 046		67.5 cm <sup>3</sup> = 068	
2	40.1 cm <sup>3</sup> = 040	41	69.0 cm <sup>3</sup> = 069	18.0 cm <sup>3</sup> = 018	4	69.0 cm <sup>3</sup> = 069	
	45.4 cm <sup>3</sup> = 045		81.6 cm <sup>3</sup> = 082	27.4 cm <sup>3</sup> = 027		81.6 cm <sup>3</sup> = 082	
	55.2 cm <sup>3</sup> = 055		97.7 cm <sup>3</sup> = 098	36.4 cm <sup>3</sup> = 036		97.7 cm <sup>3</sup> = 098	
	60.0 cm <sup>3</sup> = 060		112.7 cm <sup>3</sup> = 113	39.5 cm <sup>3</sup> = 040		112.7 cm <sup>3</sup> = 113	
	67.5 cm <sup>3</sup> = 068		121.6 cm <sup>3</sup> = 122	45.9 cm <sup>3</sup> = 046		121.6 cm <sup>3</sup> = 122	
4	69.0 cm <sup>3</sup> = 069	42	69.0 cm <sup>3</sup> = 069	40.1 cm <sup>3</sup> = 040	5	138.6 cm <sup>3</sup> = 139	
	81.6 cm <sup>3</sup> = 082		81.6 cm <sup>3</sup> = 082	45.4 cm <sup>3</sup> = 045		153.5 cm <sup>3</sup> = 154	
	97.7 cm <sup>3</sup> = 098		97.7 cm <sup>3</sup> = 098	55.2 cm <sup>3</sup> = 055		162.2 cm <sup>3</sup> = 162	
	112.7 cm <sup>3</sup> = 113		112.7 cm <sup>3</sup> = 113	60.0 cm <sup>3</sup> = 060		183.4 cm <sup>3</sup> = 183	
	121.6 cm <sup>3</sup> = 122		121.6 cm <sup>3</sup> = 122	67.5 cm <sup>3</sup> = 068		193.4 cm <sup>3</sup> = 193	
5	138.6 cm <sup>3</sup> = 139	51	138.6 cm <sup>3</sup> = 139	18.0 cm <sup>3</sup> = 018			
	153.5 cm <sup>3</sup> = 154		153.5 cm <sup>3</sup> = 154	27.4 cm <sup>3</sup> = 027			
	162.2 cm <sup>3</sup> = 162		162.2 cm <sup>3</sup> = 162	162.2 cm <sup>3</sup> = 162			
	183.4 cm <sup>3</sup> = 183		183.4 cm <sup>3</sup> = 183	39.5 cm <sup>3</sup> = 040			
	193.4 cm <sup>3</sup> = 193		193.4 cm <sup>3</sup> = 193	45.9 cm <sup>3</sup> = 046			
		52	138.6 cm <sup>3</sup> = 139	40.1 cm <sup>3</sup> = 040			
			153.5 cm <sup>3</sup> = 154	45.4 cm <sup>3</sup> = 045			
			162.2 cm <sup>3</sup> = 162	55.2 cm <sup>3</sup> = 055			
			183.4 cm <sup>3</sup> = 183	60.0 cm <sup>3</sup> = 060			
			193.4 cm <sup>3</sup> = 193	67.5 cm <sup>3</sup> = 068			
		54	138.6 cm <sup>3</sup> = 139	69.0 cm <sup>3</sup> = 069			
			153.5 cm <sup>3</sup> = 154	81.6 cm <sup>3</sup> = 082			
			162.2 cm <sup>3</sup> = 162	97.7 cm <sup>3</sup> = 098			
			183.4 cm <sup>3</sup> = 183	112.7 cm <sup>3</sup> = 113			
			193.4 cm <sup>3</sup> = 193	121.6 cm <sup>3</sup> = 122			

<b>Pump type</b>	PV	-1X/	15	*	Further details in clear text
Industrial version	= V				<b>Through drive</b>
Mobil version	= Q				
<b>Series</b>		= 1X			<b>K01</b> = 82-2,16-4 (SAE-A, 9T)
Series 10 to 19 (10 to 19, unchanged installation and connection dimensions)					<b>K02</b> = 101-2,22-4 (SAE-B, 13T)
<b>Direction of rotation</b> (viewed on the shaft end)					<b>K07</b> = 127-2,32-4 (SAE-C, 14T)
Clockwise		= R			<b>Flange version</b>
Anti-clockwise		= L			<b>B</b> = 101-2 (SAE-B); (BG 1; 2; 21)
<b>Shaft end</b>					<b>C</b> = 127-2 (SAE-C)
Cylindrical drive shaft (standard)		= A <sup>1)</sup>			(BS 4; 5 and BS 41 to 54)
Cylindrical drive shaft (strengthened version) only BS 2 to 54		= B			<b>Seals</b>
Splined drive shaft		= J			<b>M</b> = NBR seals
<b>Connections</b>					<b>V</b> = FKM seals
SAE suction and pressure connections, UNC fixing screws		= 15			<b>Only for double pumps</b>
<b>Position of the pressure connection on the flange</b> (when viewed on the cover)					<b>Pressure connection location on the cover</b>
Top (0° from the inlet)		= D			(viewed on the cover)
Right (90° to the right of the inlet)		= R			<b>D</b> = Top (45° to the right of the inlet)
Left (90° to the left of the inlet)		= L			<b>R</b> = Right (135° to the right of the inlet)
Bottom (180° from the inlet)		= U			<b>L</b> = Left (45° to the left of the inlet)
<b>Ordering example single pump: PVV2-1X/055RA15DMB</b>					<b>U</b> = Bottom (135° to the left of the inlet)
<b>Ordering example double pump: PVQ52-1X/154-068RB15DDMC</b>					<b>D</b> = Top 0° from the inlet
<sup>1)</sup> Not available for through drive pumps					<b>R</b> = Right (90° to the right of the inlet)
					<b>L</b> = Left (90° to the left of the inlet)
					<b>U</b> = Bottom (180° from the inlet)

**Technical data** (for applications outside these parameters, please consult us!)

Mounting style	Flange mounting to SAE J744																				
Pipe connections	SAE flange version (UNC fixing threads)																				
Direction of rotation	Clockwise or anti-clockwise																				
Direction of flow	Inlet and outlet are independent of the direction of rotation																				
Installation	Optional, inlet connection preferably at the top																				
Drive	Direct, co-axial drive; radial and axial forces cannot be taken up																				
Build size (pump cartridge)	BS	1					2					4					5				
Nom. size ( $\approx V$ in $\text{cm}^3$ )	NS	18	27	36	40	46	40	45	55	60	68	69	82	98	113	122	139	154	162	183	193
Max. flow $q_v$ L/min at $n = 1500 \text{ min}^{-1}$ , $p = 0,7 \text{ bar}$ and $v = 25 \text{ mm}^2/\text{s}$		26	39	53	59	70	59	66	80	89	100	101	120	141	167	177	203	223	234	267	285
Operating pressure, absolute	when using fluids containing water																				
Inlet $p_{\text{min-max}}$ bar	0.83 to 2.4 (recommended: 1 ... 1.35) and phosphate ester min. of 0.9 bar																				
Outlet	Continuous for PVV $p_{\text{max}}$ bar	210	210	210	160	140	175	175	175	175	175	175	175	175	175	175	175	175	175	175	175
	Continuous for PVQ $p_{\text{max}}$ bar	210	210	210	160	140	210	210	210	210	210	210	210	210	210	210	175	175	175	175	175
Peak $p_{\text{max}}$	A max. of 10 % continuous output pressure; not longer than 0.5 seconds																				
RPM: $n_{\text{min}}$ $\text{min}^{-1}$		600					600					600					600				
*) At 1 bar	$n_{\text{max}}$ for PVV $\text{min}^{-1}$ *)	2700		2000			1800					1800					1800				
	Inlet pressure $n_{\text{max}}$ for PVQ $\text{min}^{-1}$ *)	2700					2700		2500			2500		2400			2200				
Pressure fluid	HLP mineral oil to DIN 51524 part 2																				
For use with the above stated operating data	HLP mineral oil to DIN 51524 part 2																				
Only with FKM seals ("V")																					
Phosphate ester Perm. $p_{\text{max}}$ bar	210	210	210	160	140	175	175	175	175	175	175	175	175	175	175	175	175	175	175	175	
(HFD-R) Perm. $n_{\text{max}}$ $\text{min}^{-1}$	1200																				
Pressure fluid temperature range $\vartheta$ $^{\circ}\text{C}$	- 10 to + 70, (recommended: + 30 to + 60) the permissible viscosity range must be taken into account																				
Viscosity range $v$ $\text{mm}^2/\text{s}$	13 to 860 (recommended: 13 to 54)																				
Cleanliness class to ISO code	Maximum permissible degree of contamination of the pressure fluid is to ISO 4406 class 19/16/13 <sup>1)</sup>																				
Alternative pressure fluids:	Water in oil emulsion							Water glycole fluids													
Max. perm. operating pressure bar	70							140													
	Only in conjunction with a return filter with a retention rate of $\beta_{10} \geq 100$ or more. The permissible pressure fluid temperature range is +15 $^{\circ}\text{C}$ to +50 $^{\circ}\text{C}$ . Maximum permissible RPM: 1200 $\text{min}^{-1}$																				

**Please consult us before using our fixed displacement vane pumps with these pressure fluids!**

Weight	BS	1	2	2K	4	4K	5	5K	21	41	42	51	52	54
	kg	12	14.8	19.4	23	28.7	34	38.1	20	34	34.5	43	46	54

<sup>1)</sup> The cleanliness class stated for the components must be adhered too in hydraulic systems. Effective filtration prevents faults from occurring and at the same time increases the component service life.  
For the selection of filters see catalogue sheets RE 50 070, RE 50 076 and RE 50 081.

**The above stated values for the maximum RPM are valid for an absolute pressure of 1 bar at the inlet.**

The maximum permissible RPM has to be corrected to the following diagrams in relation to the absolute pressure present at the inlet.

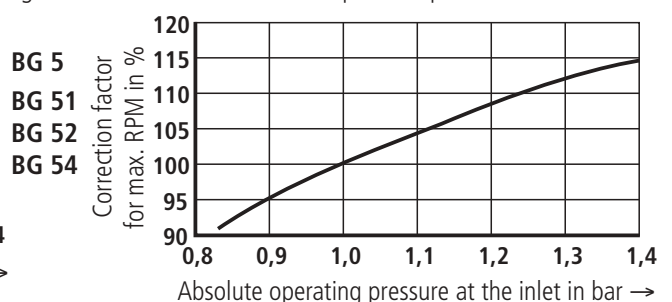
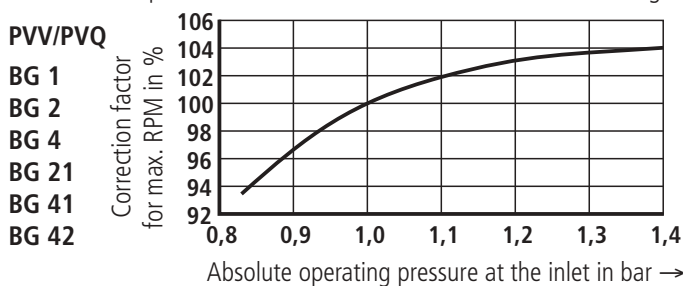

**Drive torque** (measured at  $v = 41 \text{ mm}^2/\text{s}$ ;  $\vartheta = 50 \text{ }^\circ\text{C}$ )

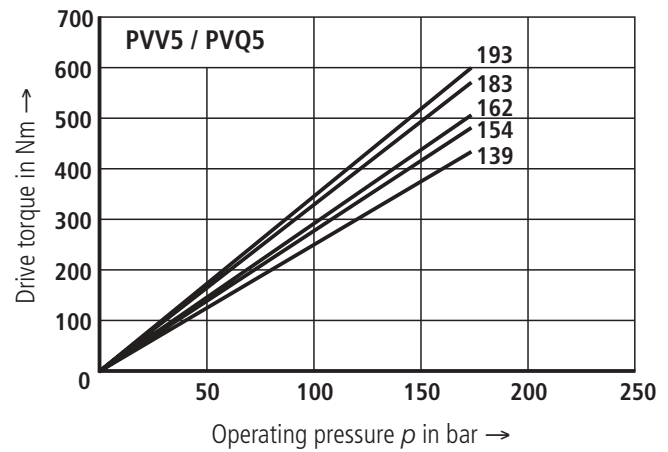
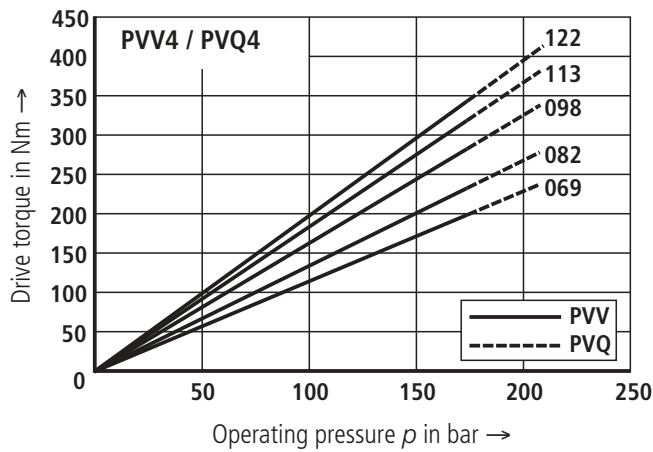
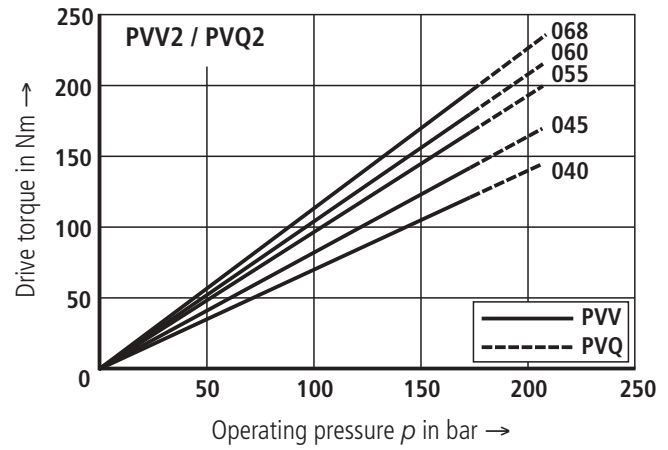
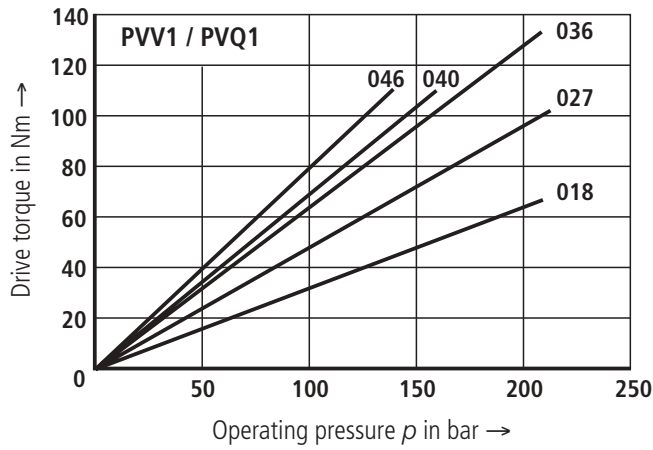

**Noise pressure level** measured in a low noise room to DIN 45 635 part 26.  
Distance of noise sensor to pump = 1 m.  $v = 41 \text{ mm}^2/\text{s}$ ;  $n = 1500$  and  $\vartheta = 50 \text{ }^\circ\text{C}$

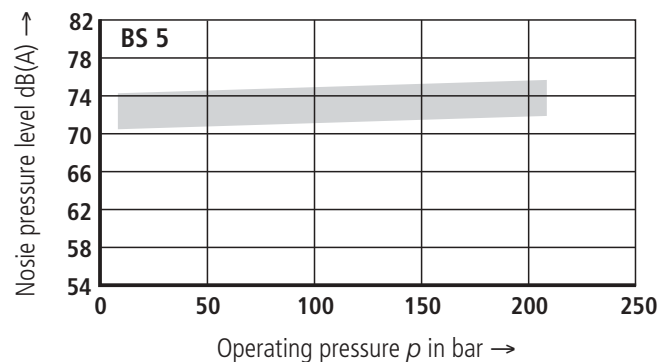
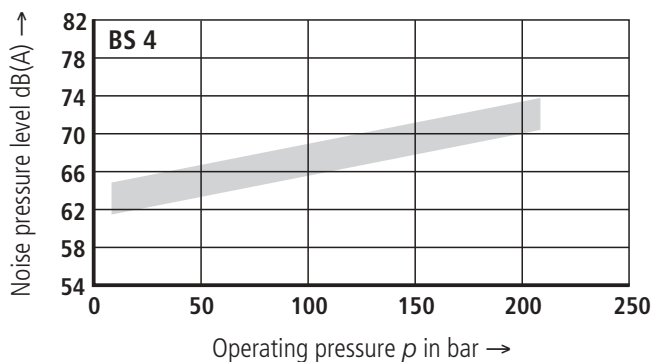
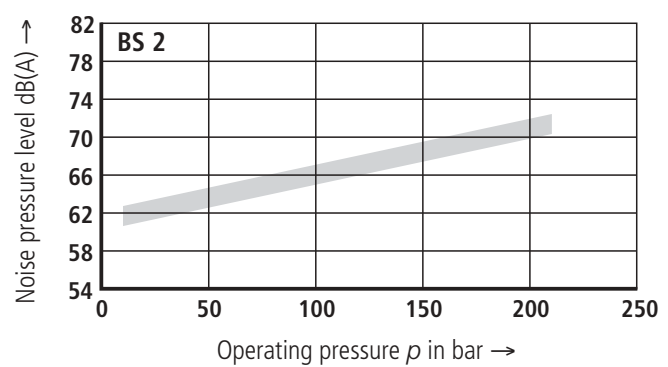
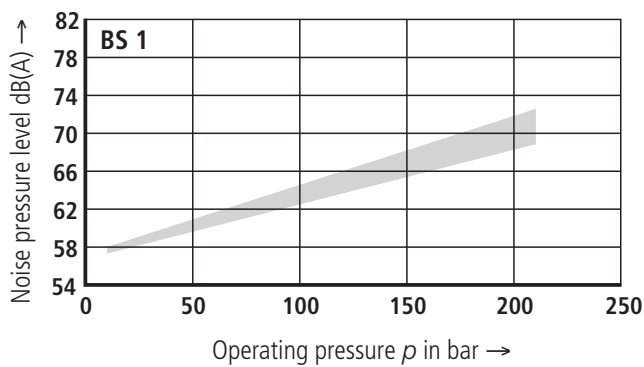

The noise pressure levels for double pumps lie on average 1 to 3 dB(A) above the values for single pumps.

$n = 1500 \text{ min}^{-1}$

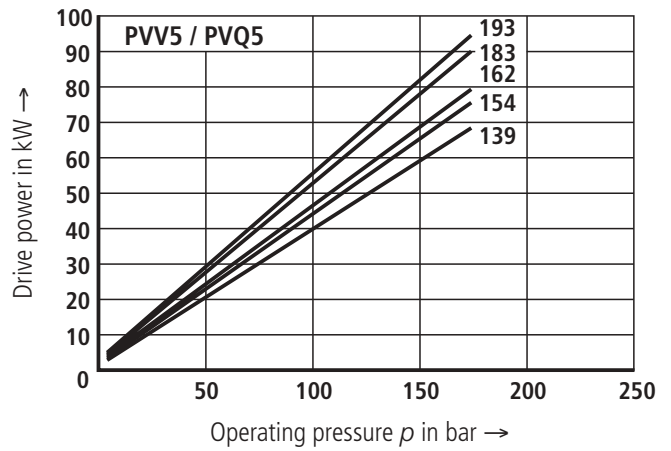
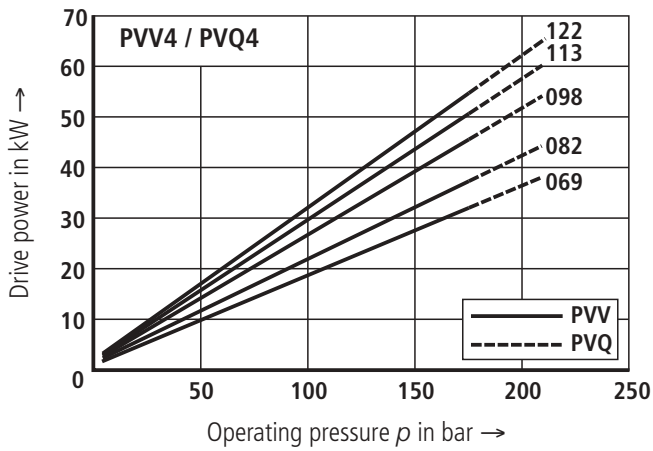
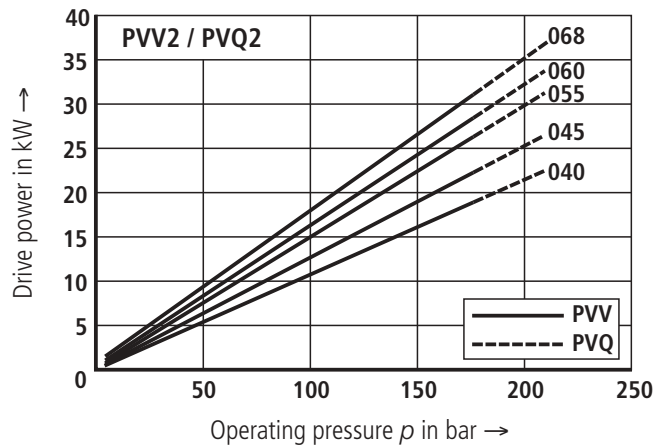
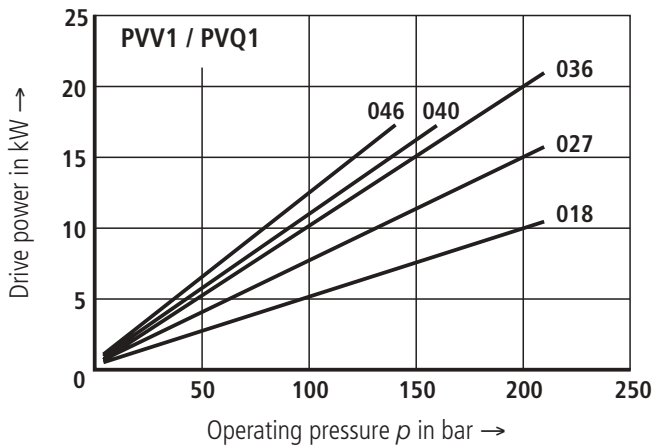

$n = 1800 \text{ min}^{-1}$

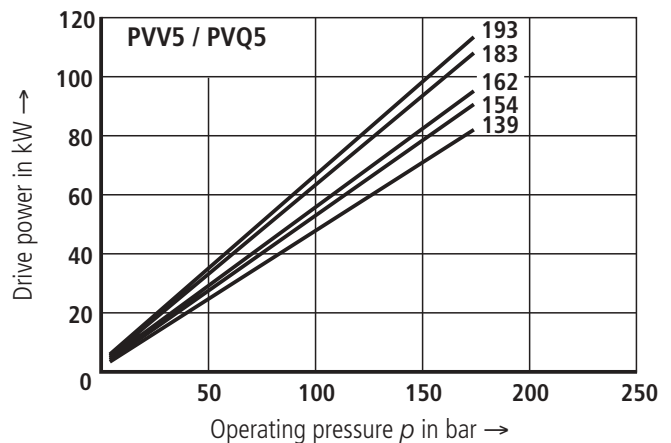
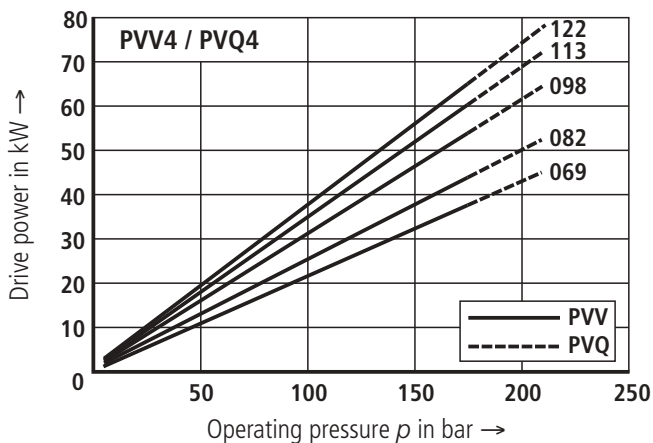
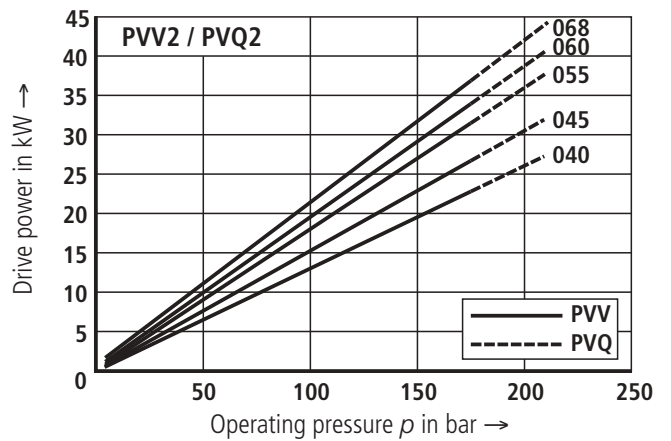
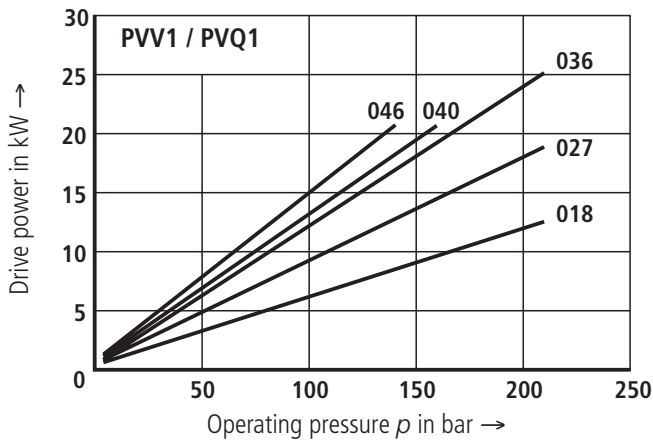

**Flow, speed dependent** (measured at  $v = 41 \text{ mm}^2/\text{s}$ ;  $\vartheta = 50 \text{ }^\circ\text{C}$ ;  $p = 7 \text{ bar}$ )

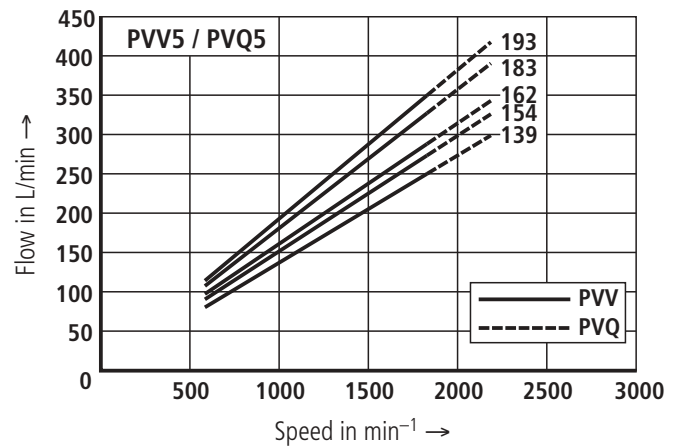
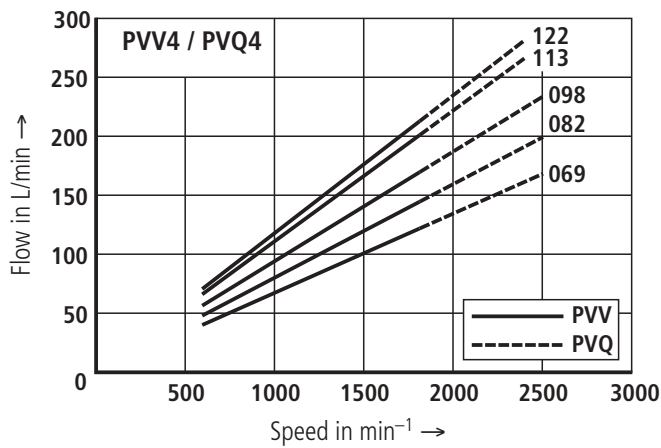
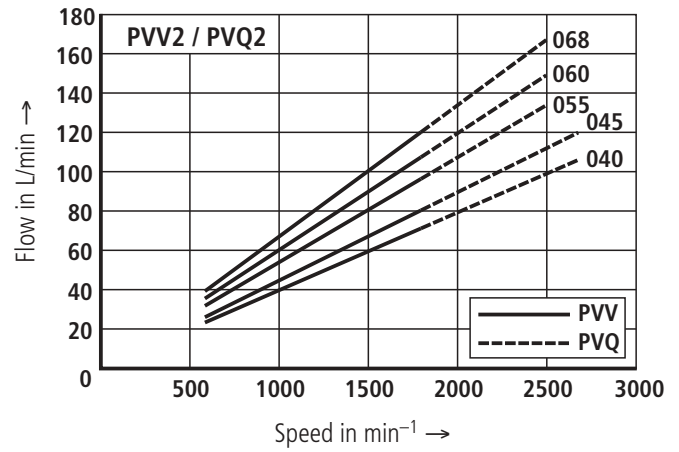
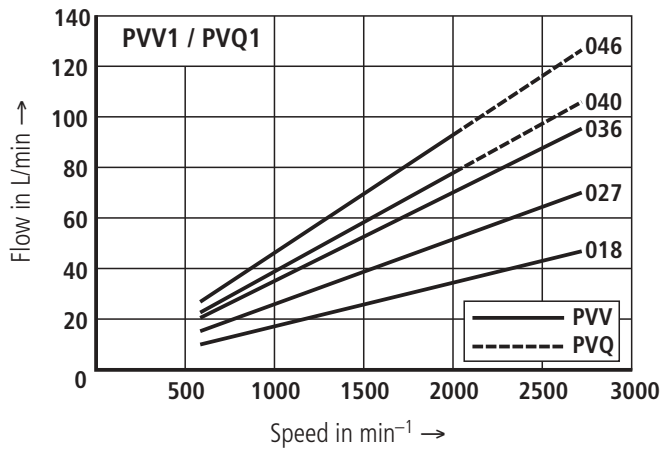

**Flow losses, pressure dependent** (measured at  $v = 41 \text{ mm}^2/\text{s}$ ;  $\vartheta = 50 \text{ }^\circ\text{C}$ )

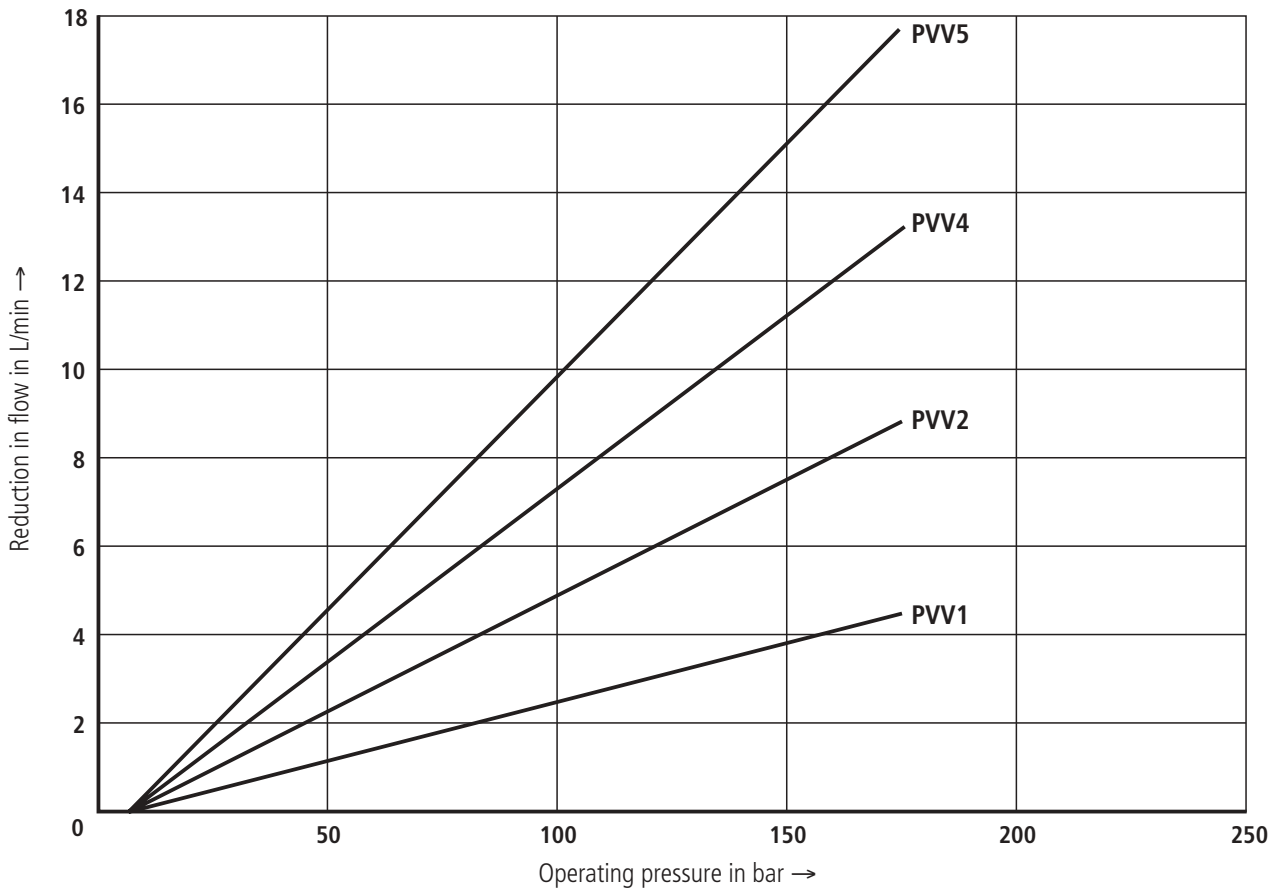



**Unit dimensions: single pumps PVV / PVQ, BS 1** (dimensions in mm)

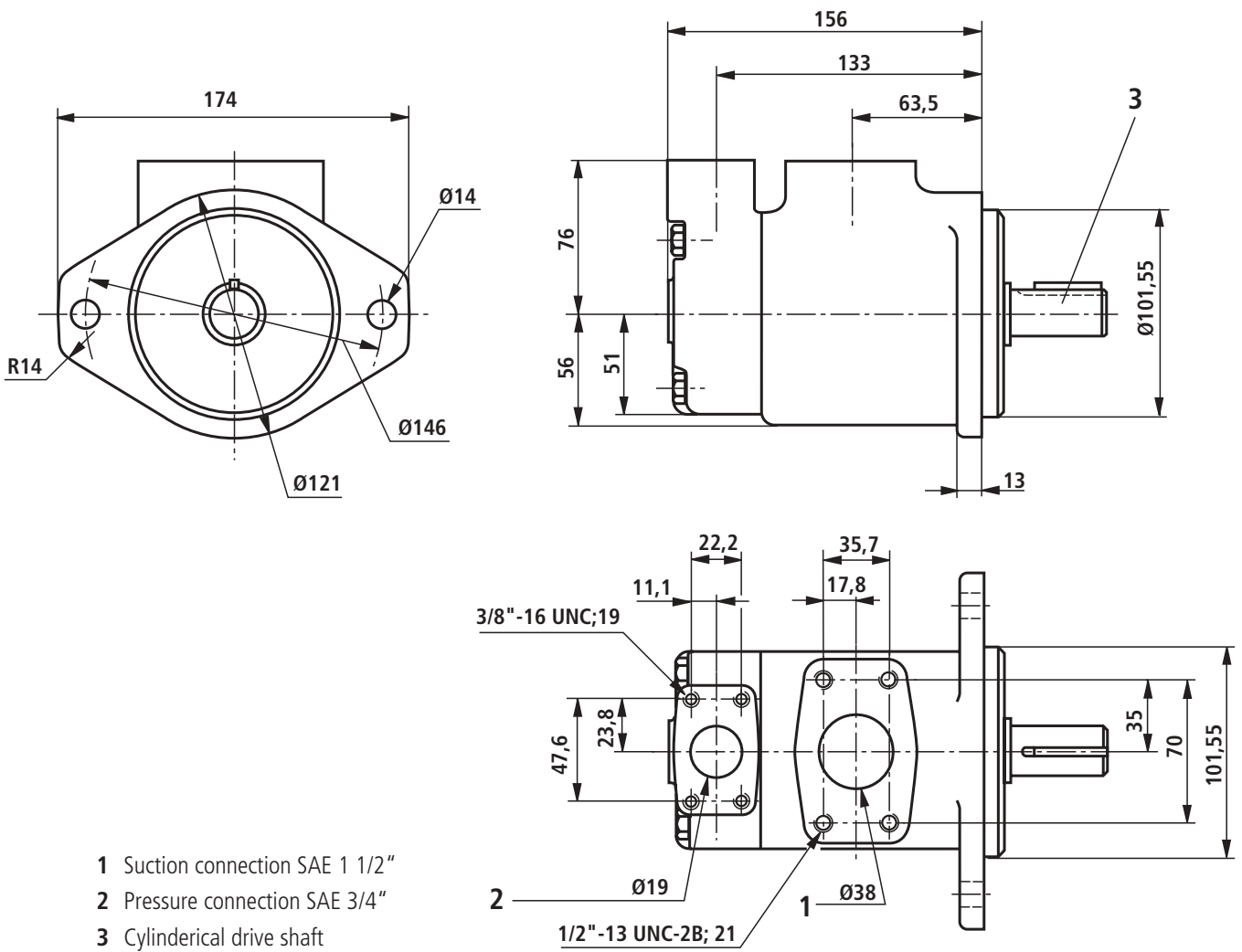

**Shaft for BS 1**

Version A  
 Cylindrical drive shaft  
 (standard)

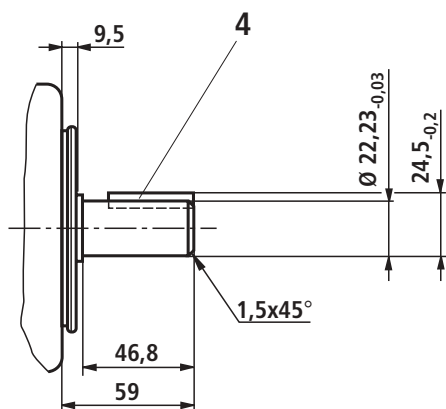

4 Key  $\square$  4.76x 31.8

Permissible torque 320 Nm

Version J  
 Splined drive shaft SAE-B 7/8"  
 13 teeth 16/32DP  
 Tooth thickness  $t = 2.261$

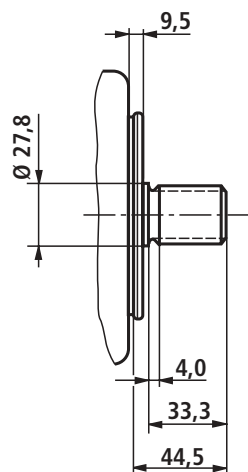

Permissible torque 320 Nm

Unit dimensions: single pumps PVV / PVQ, BS 2; 4; 5 (dimensions in mm)

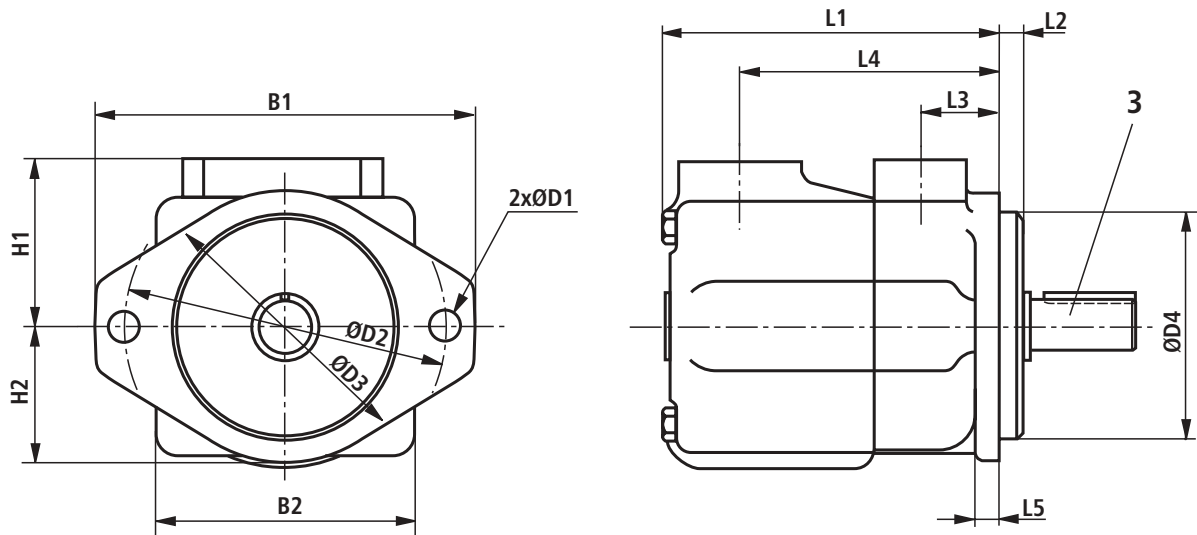

- 1 Suction connection
- 2 Pressure connection
- 3 Cylindrical drive shaft  
(for drive shaft dimensions, see page 15)

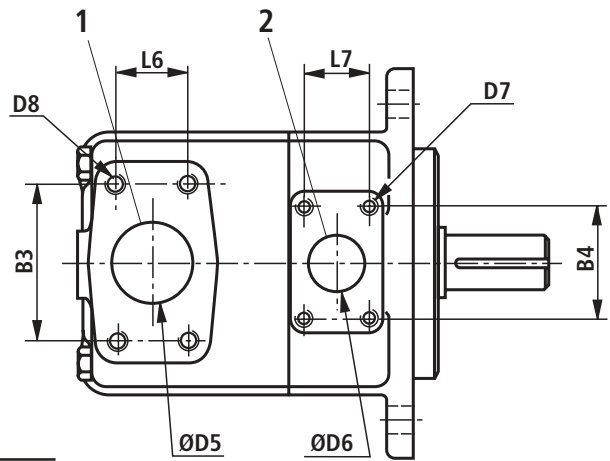

BS	Suction connection						
		ØD5	D8 <sub>-2B</sub>	B3	L6	L4	H1
2	SAE 1 1/2"	38	1/2"-13UNC	69.9	35.7	120.6	76.2
4	SAE 2"	50.8	1/2"-13UNC	77.7	42.8	125.5	82.6
5	SAE 3"	76.2	5/8"-11UNC	106.3	61.9	153.2	93.6

BS	Pressure connection					
		ØD6	D7 <sub>-2B</sub>	B4	L7	L3
2	SAE 1"	25.4	3/8"-16UNC	52.4	26.2	38.1
4	SAE 1 1/4"	31.8	7/16"-14UNC	58.7	30.1	38.1
5	SAE 1 1/2"	38.1	1/2"-13UNC	69.9	35.7	42.9

BS	Mounting flange										
		B1	ØD1	ØD2	ØD3	ØD4 <sub>-0,05</sub>	L2	L5	B2	L1	H2
2	SAE-B	174	14	146	121	101.6	9.5	13	117	163	64
4	SAE-C	212	17.5	181	148	127	9.5	16	140	186	70
5	SAE-C	212	17.5	181	148	127	12.7	16	159	216	83

Unit dimensions: PVV / PVQ 2...K.. – with through drive (dimensions in mm)

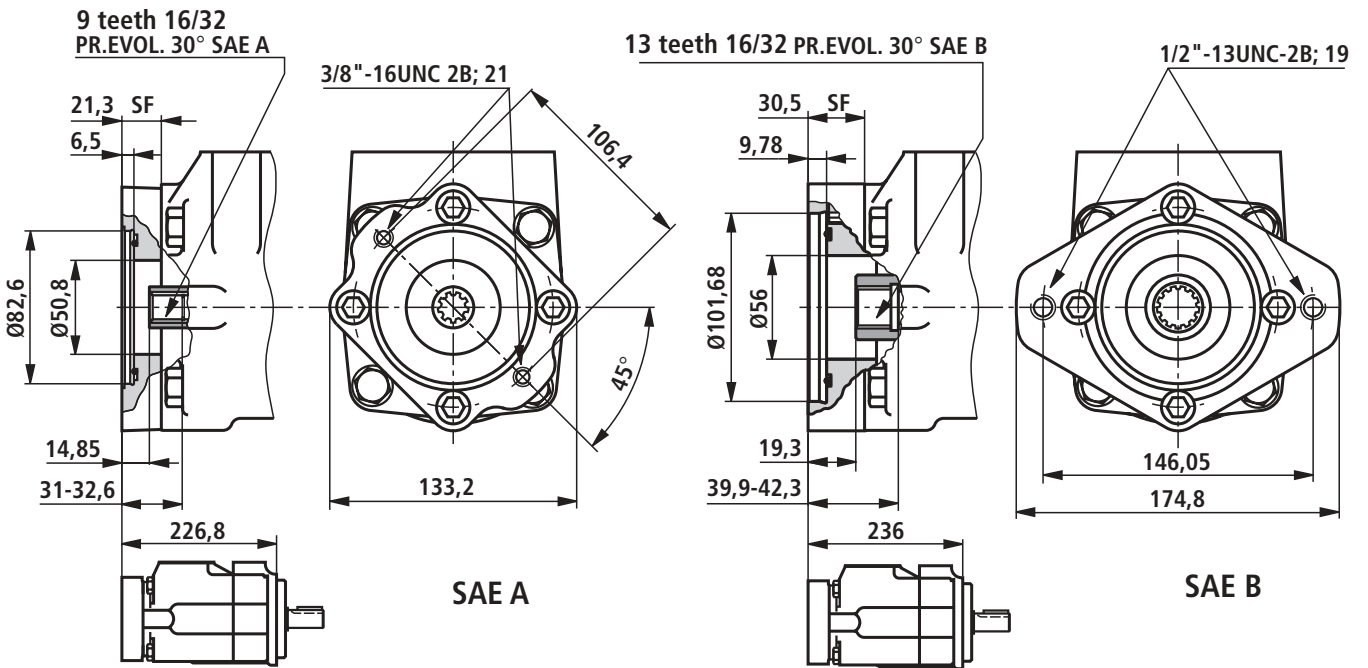
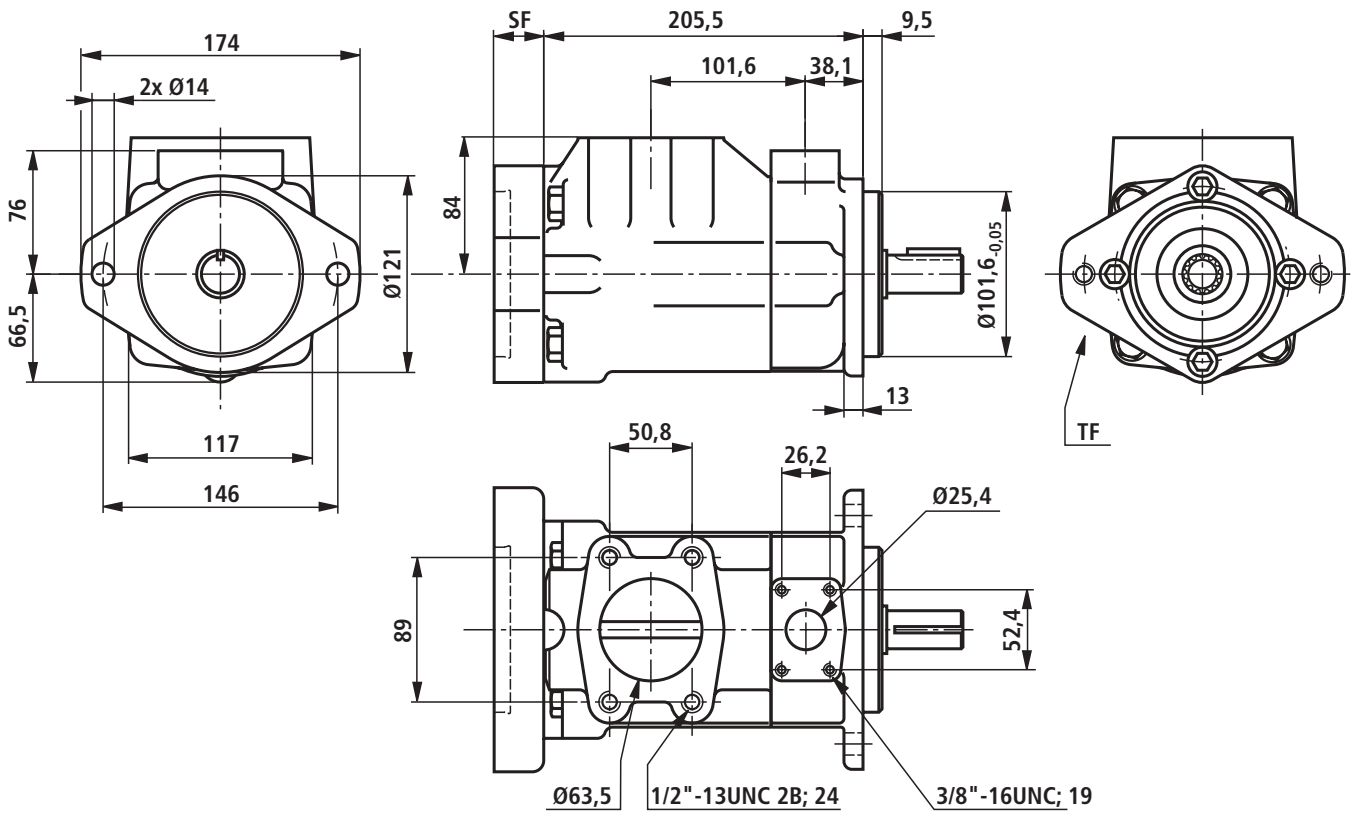

Unit dimensions: PVV / PVQ 4...K.. – with through drive (dimensions in mm)

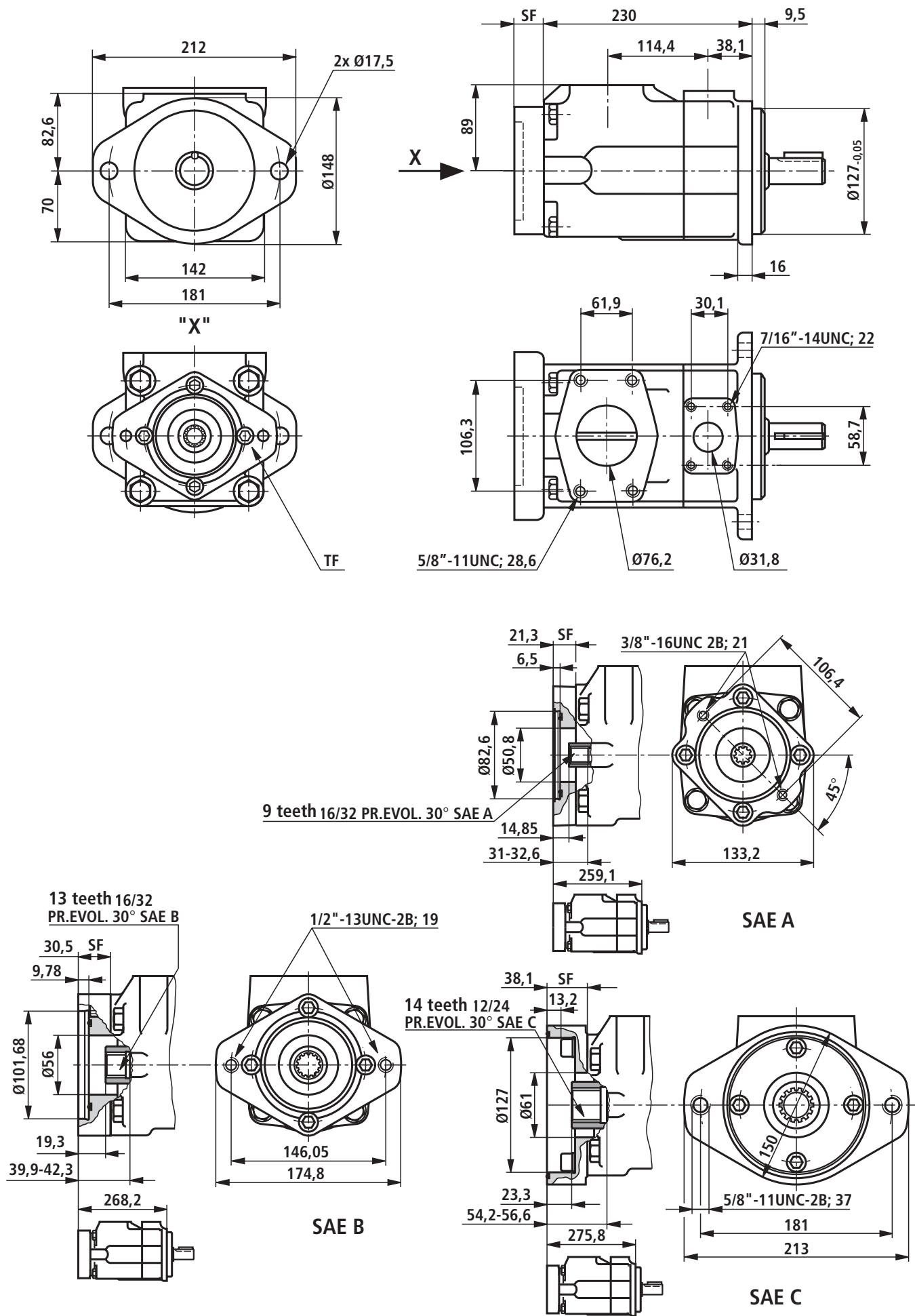

Unit dimensions: PVV / PVQ 5...K.. – with through drive (dimensions in mm)

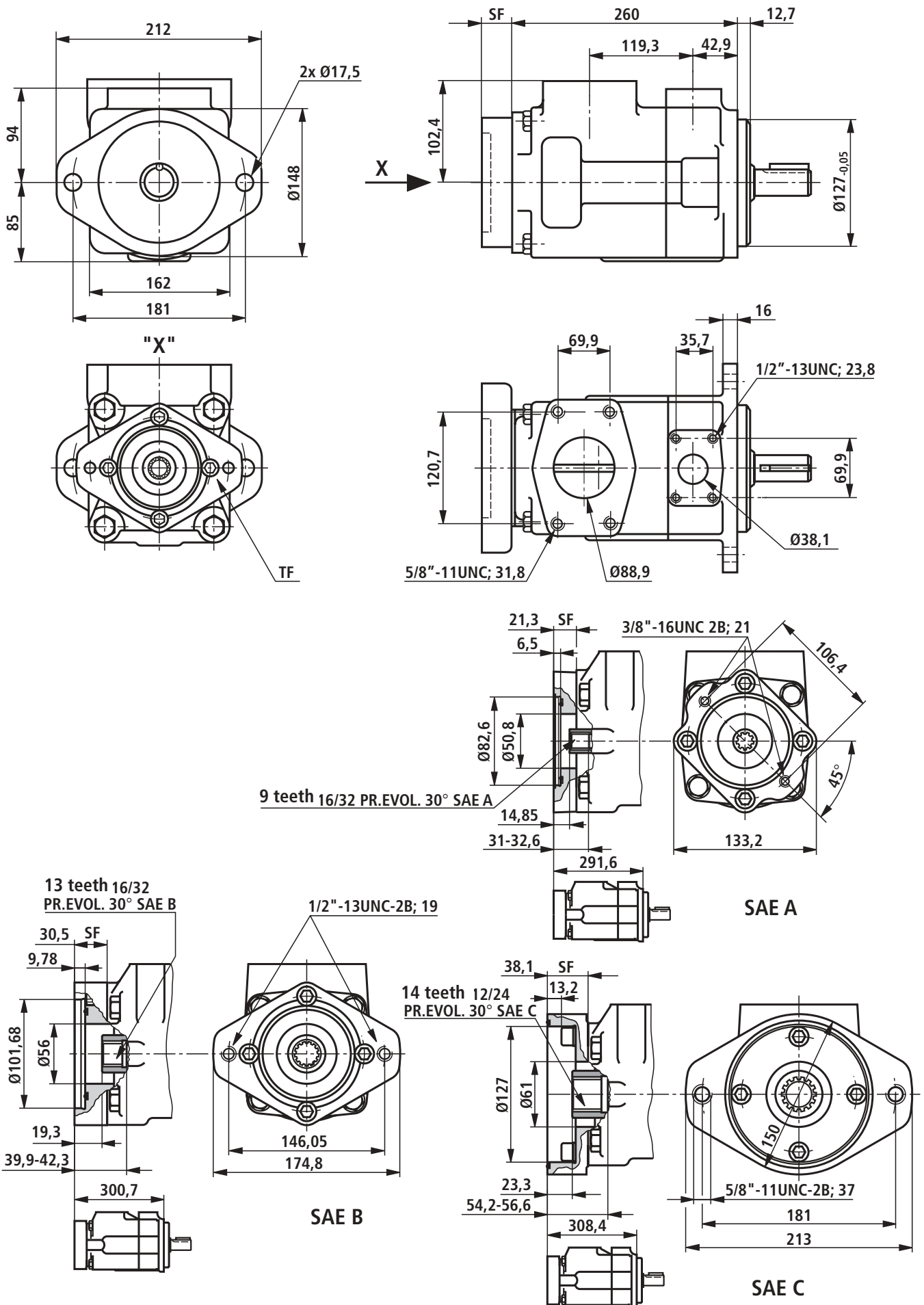

Unit dimensions: double pumps PVV / PVQ, BS 21; 41; 42; 51; 52 (dimensions in mm)

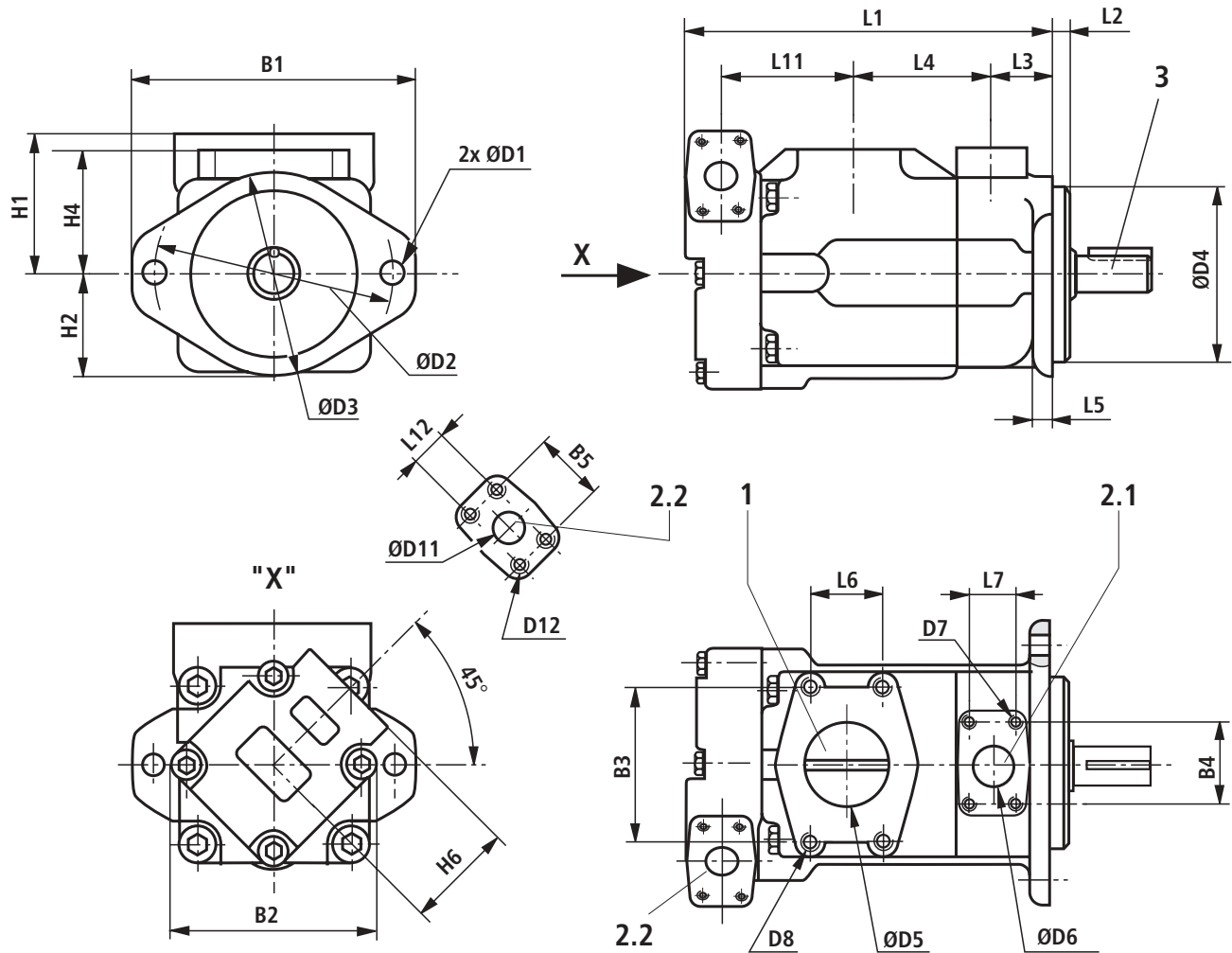

BS	Mounting flange							
		B1	ØD1	ØD2	ØD3	ØD4 <sub>-0,05</sub>	L2	L5
21	SAE-B	174	14	146	121	101.6	9.5	13
41; 42	SAE-C	212	17.5	181	148	127	9.5	16
51; 52	SAE-C	212	17.5	181	148	127	12.7	16

BS	Suction connection						
		ØD5	D8 <sub>-2B</sub>	B3	L6	L4	H1
21	SAE 2 1/2"	63.5	1/2"-13UNC	88.5	50.8	101.6	84.1
41	SAE 3"	76.2	5/8"-11UNC	106.3	61.9	114.4	88.9
42							
51	SAE 3 1/2"	88.9	5/8"-11UNC	120.7	69.9	119.3	102.4
52							

BS	Pressure connection - flange side						
		ØD6	D7 <sub>-2B</sub>	B4	L7	L3	H4
21	SAE 1"	25.4	3/8"-16UNC	52.4	26.2	38.1	76.2
41; 42	SAE 1 1/4"	31.8	7/16"-14UNC	58.7	30.1	38.1	82.6
51; 52	SAE 1 1/2"	38.1	1/2"-13UNC	69.9	35.7	42.9	93.6

BS	Pressure connection - cover side								B2	L1	H2
		ØD11	D12 <sub>-2B</sub>	B5	L12	L11	H6				
21	SAE 3/4"	19.1	3/8"-16UNC	47.6	22.2	88	76.2	132	252	64	
41	SAE 3/4"	19.1	3/8"-16UNC	47.6	22.2	99.5	74.7	140	275	70	
42	SAE 1"	25.4		52.4	26.2	109.5	76.2	143	288	74	
51	SAE 3/4"	19.1	3/8"-16UNC	47.6	22.2	119.5	74.7	162	306	85	
52	SAE 1"	25.4		52.4	26.2	135.8	76.2		324		

- 1 Suction connection
- 2.1 Pressure connection, flange side
- 2.2 Pressure connection, cover side
- 3 Cylindrical drive shaft  
(for drive shaft dimensions, see page 15)

**Unit dimensions: double pumps PVV / PVQ, BS 54 (dimensions in mm)**

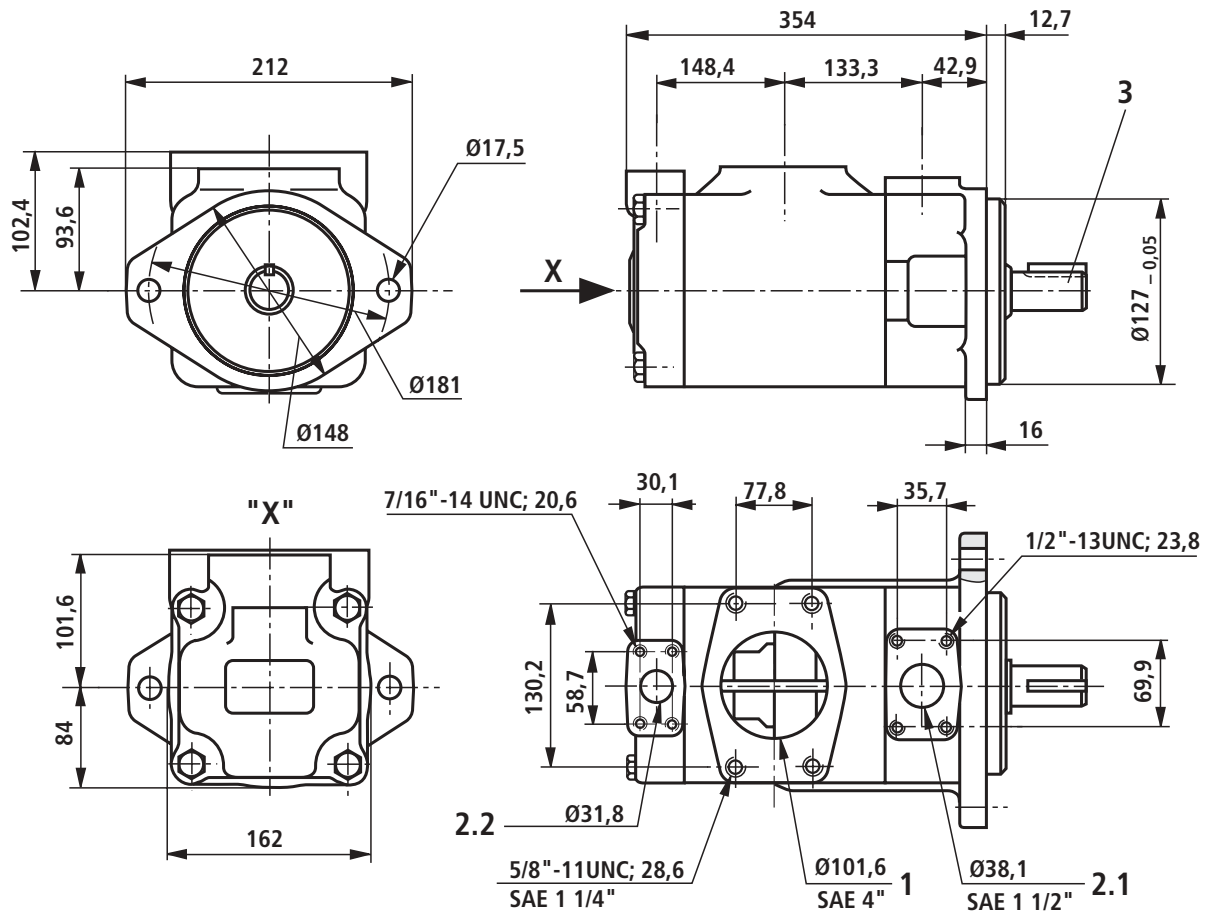

**Drive shaft for BS 2 to 54**

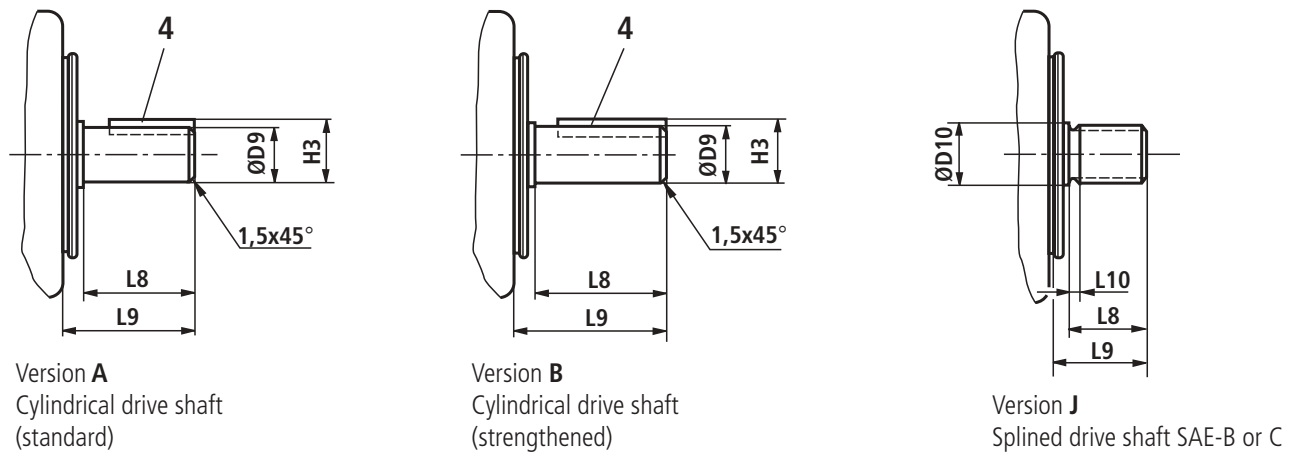

BS	Drive shaft version A						Drive shaft version B					
	L8	L9	H3	$\varnothing D9$	Key	$T_{max}$ in Nm	L8	L9	H3	$\varnothing D9$	Key	$T_{max}$ in Nm
2; 21	46.8	59	24.5 <sub>-0.2</sub>	22.23 <sub>-0.03</sub>	□ 4.76x31.8	250	64	78	28.3 <sub>-0.2</sub>	25.37 <sub>-0.02</sub>	□ 6.36x50.8	400
4; 41; 42	61.9	73,2	35.2 <sub>-0.3</sub>	31.75 <sub>-0.03</sub>	□ 7.9x38.1	407	74.6	86	38.6 <sub>-0.3</sub>	34.9 <sub>-0.03</sub>	□ 7.9x54.6	600
5; 51; 52; 54	47.8	62	35.2 <sub>-0.3</sub>	31.75 <sub>-0.03</sub>	□ 7.9x28.4	610	73	88	42.37 <sub>-0.23</sub>	38.07 <sub>-0.02</sub>	□ 9.5x54.6	818

BS	Drive shaft version J					Teeth details
	L8	L9	L10	$\varnothing D10$	$T_{max}$ in Nm	
2; 21	33.3	44.5	4.0	27.8	320	SAE-B 7/8", 13 teeth, 16/32 DP
4; 41; 42	42.1	58.42	3.04	35.05	580	SAE-C 1 1/4", 14 teeth, 12/24 DP
5; 51; 52; 54	46.6	62	9.7	41.28	818	SAE-C 1 1/4", 14 teeth, 12/24 DP

- 1 Suction connection
- 2.1 Pressure connection, flange side
- 2.2 Pressure connection, cover side
- 3 Cylindrical drive shaft (for drive shaft dimensions, see table)
- 4 Key (for dimensions, see table)

## Pump cartridges for PVV / PVQ

### Features

- Service friendly due to exchangeable pump cartridges
- Within a build size it is possible to change the flow by exchanging the pump cartridges
- The pump can be changed from type PVV to PVQ or from PVQ to PVV by changing the cartridges.

H/A/D5768/97



Type: CARTRIDGE PVV1-1X/018R

### Ordering details

EINBAUSATZ	PV		- 1X/		
------------	----	--	-------	--	--

#### Pump type

Industrial version

= V

Mobil version

= Q

Build size 1

= 1

Build size 2

= 2

Build size 4

= 4

Build size 5

= 5

#### Series

Series 10 to 19

= 1X

(10 to 19: unchanged installation and connection dimensions)

**No code** = Cartridge for single pumps  
or flange size for double pumps

**D** = Cartridge for cover side  
installation for double pumps

#### Direction of rotation

**R** = Clockwise

**L** = Anti-clockwise

#### Nominal size/displacement

<b>018</b> =		18.0 cm <sup>3</sup>
<b>027</b> =		27.4 cm <sup>3</sup>
<b>036</b> =	Build size 1	45.4 cm <sup>3</sup>
<b>040</b> =		39.5 cm <sup>3</sup>
<b>046</b> =		45.9 cm <sup>3</sup>
<b>040</b> =		40.1 cm <sup>3</sup>
<b>045</b> =		45.4 cm <sup>3</sup>
<b>055</b> =	Build size 2	55.2 cm <sup>3</sup>
<b>060</b> =		60.0 cm <sup>3</sup>
<b>068</b> =		67.5 cm <sup>3</sup>
<b>069</b> =		69.0 cm <sup>3</sup>
<b>082</b> =		81.6 cm <sup>3</sup>
<b>098</b> =	Build size 4	97.7 cm <sup>3</sup>
<b>113</b> =		112.7 cm <sup>3</sup>
<b>122</b> =		121.6 cm <sup>3</sup>
<b>139</b> =		138.6 cm <sup>3</sup>
<b>154</b> =		153.5 cm <sup>3</sup>
<b>162</b> =	Build size 5	162.2 cm <sup>3</sup>
<b>183</b> =		183.4 cm <sup>3</sup>
<b>193</b> =		193.4 cm <sup>3</sup>



## SAE connection flanges (dimensions in mm)

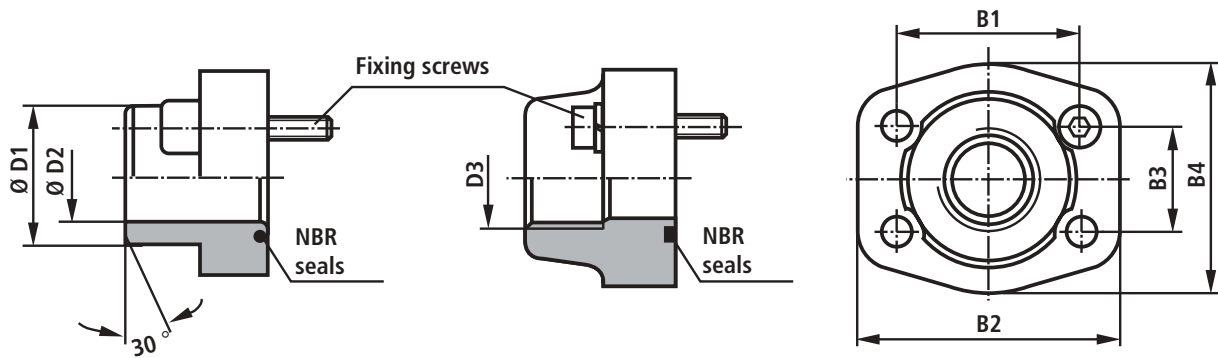

**With welded connections to AB-E 22-15**

**With threaded connections to AB-E 22-13**

Suction connection for PVV / PVQ	Pressure connection for PVV / PVQ *)	NS	Seal material	Material No. for flange with		B1	B2	B3	B4	ØD1	ØD2	D3	Fixing screws
				Welded connection	Threaded connection								
	<b>1; 21; 41; 51</b>	3/4"	NBR	211169	063050	47.6	65	22.2	52	25	19	G3/4	3/8"-16UNC
	<b>2; 21; 42; 52</b>	1"	NBR	211170	211175	52.4	70	26.2	59	30	22	G 1	3/8"-16UNC
	<b>4; 41; 42; 54</b>	1 1/4"	NBR	211363	211172	58.7	79	30.2	68	38	28	G 1 1/4	7/16"-14UNC
	<b>5; 51; 52; 54</b>	1 1/2"	NBR	211168	211171	69.9	95	35.7	76	38	30	G 1 1/2	1/2"-13UNC
1; 2		1 1/2"	NBR	211165	211171	69.9	95	35.7	76	48	39	G 1 1/2	1/2"-13UNC
4		2"	NBR	211434	211173	77.8	102	42.9	90	60	49	G 2	1/2"-13UNC
21		2 1/2"	NBR	063063	211174	88.9	114	50.8	104	76	62	G 2 1/2	1/2"-13UNC
5; 41; 42		3"	NBR	211362	—	106.3	135	61.9	131	76	70	—	5/8"-11UNC
51; 52		3 1/2"	NBR	211166	—	130.7	152	69.9	140	89	82	—	5/8"-11UNC
54		4"	NBR	211167	—	130.2	162	77.8	152	114	107	—	5/8"-11UNC

\*) The numbers in bold states the stage (for double pumps) for which the flange intended.

The material numbers contain the flange, the O-ring and the fixing screws.

Pipe thread "G" to ISO 228/1

## Pump safety block

To limit the working pressure or (and) for solenoid operated unloading of the operating pressure we recommend the use of our pump safety blocks to RE 25 880 and RE 25 890.

## Engineering guidelines

---

Comprehensive guidelines and proposals can be found in the Hydraulic Trainer, Volume 3 RE 00 281, "Planning and design of hydraulic power systems"

When using vane pumps we recommend that the following guidelines are partially taken into account.

### Technical data

All the technical data are dependent on manufacturing tolerances and are valid with certain operating conditions.

Please take into account that minor variations are possible and technical data can be affected by differing conditions (e.g. viscosity).

### Characteristic curves

Please take into account when dimensioning the drive motor, the maximum possible application data as shown by the characteristic curves on pages 6 to 8.

## Commissioning guidelines

---

### Commissioning

- Check to see if the system has been carefully, correctly and cleanly assembled.
- Only fill the pressure fluid via a filter which has the necessary retention rate.
- Take into account the direction of rotation arrow.
- Start the pump without load and let it displace oil without pressure for a few seconds, in order to provide sufficient lubrication.
- Never run the pump without oil.
- If the pump, after approx. 20, does not displace oil without any bubbles then the system has to be rechecked  
After the operating values have been reached, check the pipe connections for leakage and check the operating temperature.

### Bleeding

- Before commissioning we recommend that the housing and suction line are filled with oil. This increases the operating safety and prevents wear in the case of unfavourable installation conditions.
- For the first commissioning the oil, which has foamed, can be released by carefully loosening the pressure flange (danger of oil spray) when the system is in a de-pressurised condition. Only when bubble-free oil is being released retighten the fittings to the required torque level.

### Noise

The sound pressure level values given on page 6 are measured according to DIN 45 635, page 26. This means that only the noise emission of the pump is given. Ambient influences (such as place of installation, piping, etc. ) are **not** taken into account.

The values only refer to one pump.

Unfavourable influences can cause the noise pressure level at the units final place of installation to be 5 to 10 dB (A) higher than that of the pump values alone.

### General

- The pumps supplied by ourselves have been tested for function and performance. Changes in any form or manner to the pump are not permitted, as this would invalidate any guarantee claims!
- Repairs may only be carried out by the manufacturer or authorised agent or subsidiary. No guarantee will be accepted for commissioning carried out by third parties.

### Important guidelines

- Assembly, maintenance and servicing must only be carried out by authorised, trained and instructed personnel!
- The pumps must only be operated within the permitted limits (see page 5)!
- The pump may only be operated in a sound condition!
- When carrying out any work on the pump, switch the system to zero pressure!
- Unauthorised conversions and modifications which affect the safety and function of the pump are not permitted!
- Provide protective measures (e.g. coupling guard) and do not remove any existing protective devices!
- Ensure that the fixing bolts are correctly fitted! (take into account the prescribed tightening torques)
- The general valid safety and accident prevention regulations must be adhered to!

## Installation guidelines

### Drive

E-motor + pump mounting bracket + coupling + pump

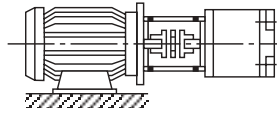

#### Attention!

- Radial and axial forces on the pump drive shaft are not permitted!
  - Motor and pump must be exactly aligned!
  - Use flexible drive couplings

### Fluid tank

- Match the service capacity of the tank to the operating conditions.

**Attention!** The permissible fluid temperature must not be exceeded

→ If required, provide a cooler!

### Lines and connections

- Cut at a 45° angle
- Remove protective plugs from the pump.
- We recommend the use of seamless precision steel pipes to DIN 2391 and removable pipe connections.
- Select the inside diameter of the pipes according to the ports.
- Thoroughly clean the pipes and fittings before assembly. – **min. distance to the tank bottom 120 mm**
  - Dirt deposits will not be sucked up or whirled up
- Maintain a min. immersion depth of 50 mm, even at the lowest permissible fluid level
  - Foaming will be prevented
- Under no circumstances must leakage and return fluid be directly taken up by the pump!
  - Fluid temperature remains low
- For inlet pressure see page 5

### Piping recommendations

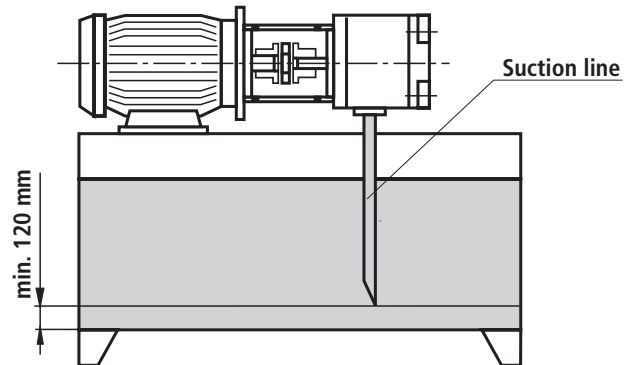

- **Under no circumstances** may return fluid be directly taken up, therefore select the greatest possible distance between the suction and return lines
- The exit of the return line must always lie under the oil level
- Ensure that the suction lines are assembled leak-proof

### Filter

- Whenever possible, use return line or pressure filters. (Suction filter only in connection with low pressure switch/ clogging indicator)

### Pressure fluid

- Please take into account the specifications stated in catalogue sheet RE 07 075.
- We recommend the use of brand name fluids.
- Do not mix hydraulic fluids of different types since this can result in decomposition or deterioration of the lubricating quality.
- The fluid must be replaced at regular intervals according to the operating conditions. In connection with this, the tank must also be cleaned of residues.

### Permissible installation positions

- Horizontal position preferred

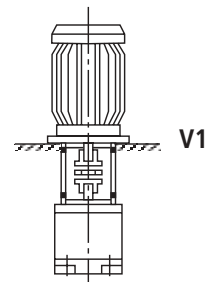
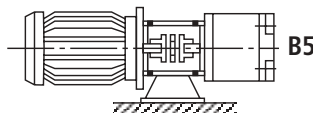
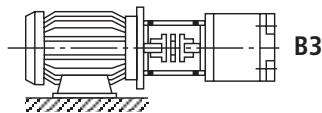

---

**Bosch Rexroth AG  
Industrial Hydraulics**

D-97813 Lohr am Main  
Zum Eisengießer 1 • D-97816 Lohr am Main  
Telefon 0 93 52 / 18-0  
Telefax 0 93 52 / 18-23 58 • Telex 6 89 418-0  
eMail [documentation@boschrexroth.de](mailto:documentation@boschrexroth.de)  
Internet [www.boschrexroth.de](http://www.boschrexroth.de)

**Bosch Rexroth Limited**

Cromwell Road, St Neots,  
Cambs, PE19 2ES  
Tel: 0 14 80/22 32 56  
Fax: 0 14 80/21 90 52  
E-mail: [info@boschrexroth.co.uk](mailto:info@boschrexroth.co.uk)

The data specified above only serves to describe the product. No statements concerning a certain condition or suitability for a certain application can be derived from our information. It must be remembered that our products are subject to a natural process of wear and ageing.