

RV1-12 - Relief valve

Poppet, direct acting
 114 L/min (30 USgpm) • 350 bar (5000 psi)

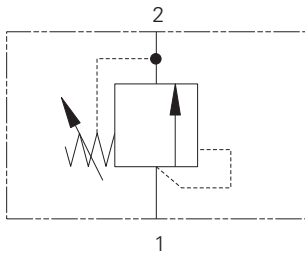

Sectional view

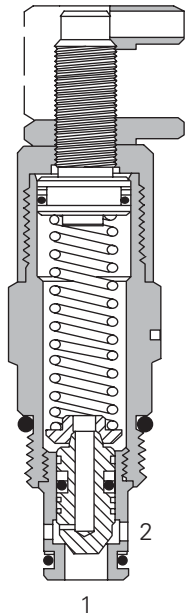

Operation

This valve remains closed from port 1 to port 2 until the predetermined setting has been reached at port 1.

The poppet is unseated and allows flow out of port 2.

Features

Hardened and ground working parts. Low leakage poppet design. High flow rate for a compact cartridge.

Performance data

Ratings and specifications

Performance data is typical with fluid at 23,3 cSt (111 SUS) and 49° C (120° F)

Typical application pressure (all ports)	350 bar (5000 psi)
Cartridge fatigue pressure (infinite life)	350 bar (5000 psi)
Rated flow	114 L/min (30 USgpm)
Cracking pressure ranges	3,4-275 bar (50-4000 psi)
Temperature range	-40° to 120°C (-40° to 248°F)
Cavity	C-12-2 or C-12-2U
Fluids	All general purpose hydraulic fluids such as: MIL-H-5606, SAE 10, SAE 20, etc.
Filtration	Cleanliness Code 18/ 16/13
Standard housing materials	Aluminum or Steel
Weight cartridge only	0,49 kg (1.08 lbs)
Seal kit	02-165881 (Buna-N) 02-165888 (Viton®)

Viton is a registered trademark of E.I. DuPont

Endurance tested to 1 million cycles at full rated flow and pressure.

Description

This is a direct acting, poppet style screw in cartridge relief valve ideal for low cost applications to limit the pressure in the system.

Pressure override curves

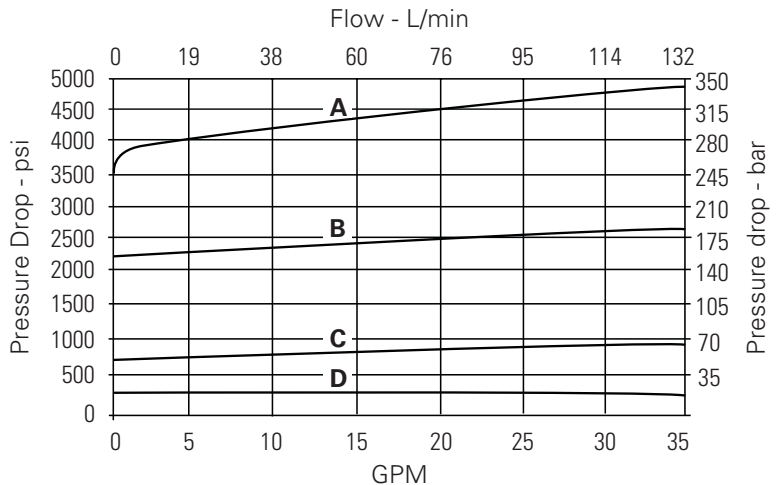

- A - 40 spring
- B - 22 spring
- C - 8.5 spring
- D - 2.5 spring

Where measurements are critical request certified drawings. We reserve the right to change specifications without notice.

RV1-12 - Relief valve

Poppet, direct acting
114 L/min (30 USgpm) • 350 bar (5000 psi)

Model code

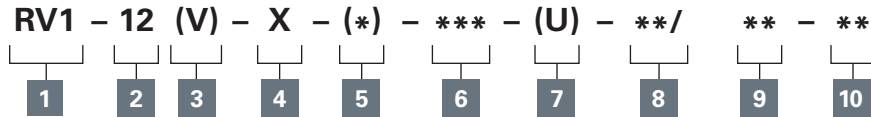

1 Function

RV1 - Relief valve

2 Size

12 - 12 size

3 Seal material

Blank - Buna-N
V - Viton®

4 Adjustment

C - Cap
K - Knob
F - Factory set
S - Screw

5 Valve housing material

Omit for cartridge only
A - Aluminum
S - Steel

6 Port size

Code	Port size	Housing number			
		C-12-2 Aluminum fatigue rated	C-12-2U Aluminum fatigue rated	C-12-2 Steel fatigue rated	C-12-2U Steel fatigue rated
4G	1/2" BSPP	30189-1	30189-2	30915-1	30915-2
6G	1/4" BSPP	31090-1	31090-2	30916-1	30916-2
10T	SAE 10	31087-1	31087-2	30913-1	30913-2
12T	SAE 12	31088-1	31088-2	30914-1	30914-2

See section J for housing.

7 Cavity

Blank - Cavity without undercut
U - Cavity with undercut

8 Cracking pressure range

Note: Code based on pressure in psi.
2.5 - 3,4-17 bar (50-250 psi)
8.5 -13-55 bar (200-850 psi)
22 - 20-150 bar (300-2200 psi)
40 - 40-275 bar (600-4000 psi)

9 Setting pressure

Within ranges in **8**
Blank - Normal factory setting at approximate mid-range.
Optional - User requested settings in 3,45 bar (50 psi) steps, Coded as in the following examples:
10 - 70 bar (1000 psi)
10.5 - 72,4 bar (1050 psi)

10 Special features

00 - None
(Only required if valve has special features, omitted if "00.")

Dimensions

mm (inch)

Cartridge only

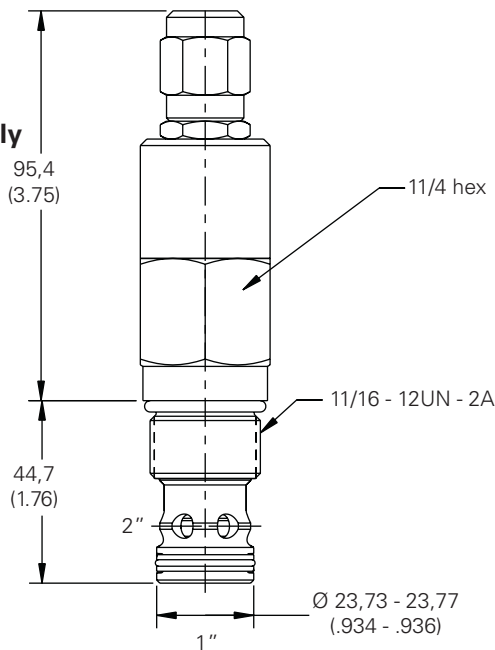

ADJUSTMENT CODE C

Torque cartridge in housing
A - 81-95 Nm (60-70 ft. lbs)
S - 102-115 Nm (75-85 ft. lbs)

Warning

Aluminum housings can be used for pressures up to 210 bar (3000 psi). Steel housings must be used for operating pressures above 210 bar (3000 psi).

Installation drawing (Steel)

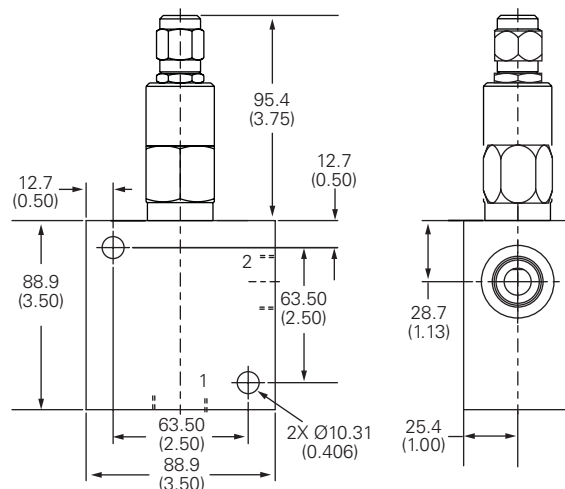

Where measurements are critical request certified drawings. We reserve the right to change specifications without notice.