

PSV2-10 - Pressure sequence valve

Spool, direct acting, normally closed, internal drain
 23 L/min (6 USgpm) • 210 bar (3000 psi)

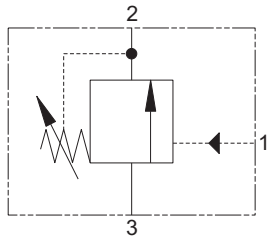

Operation

When a pre-set pilot pressure is reached the spool moves back against the spring opening the line between inlet and outlet.

When the pilot pressure falls the valve will return to its normal position.

Features

Cartridge design enabling speedy servicing when mounted in a body or in a composite manifold.

Sectional view

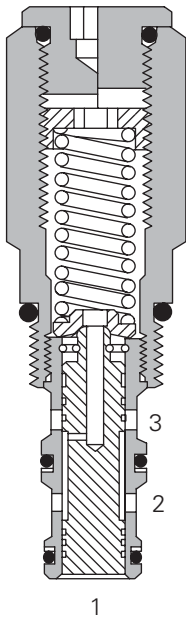

Performance data

Ratings and specifications

Performance data is typical with fluid at 21,8 cSt (105 SUS) and 49°C (120°F)

Typical application pressure (all ports)	210 bar (3000 psi)
Cartridge fatigue pressure (infinite life)	210 bar (3000 psi)
Maximum sequence pressure	165 bar (2400 psi)
Rated flow	23 L/min (6 USgpm)
Cavity	C-10-3
Standard housing materials	Aluminum
Temperature range	-40° to 120°C (-40° to 248°F)
Fluids	All general purpose hydraulic fluids such as: MIL-H-5606, SAE 10, SAE 20, etc.
Filtration	Cleanliness Code 18/ 16/13
Weight cartridge only	0,24 kg (0.53 lbs)
Seal kits	565804 Buna-N 889599 Viton®

Viton is a registered trademark of E.I. DuPont

Description

This valve provides a means of opening a pressure line when a predetermined pilot pressure is reached in a normally closed form.

The valve can be used in any pilot or small flow system as a remotely operated sequence valve.

Pressure drop curve

Cartridge only

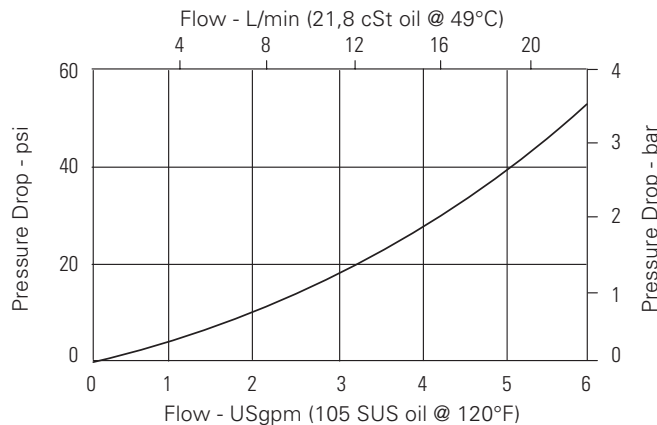

Where measurements are critical request certified drawings. We reserve the right to change specifications without notice.

PSV2-10 - Pressure sequence valve

Spool, direct acting, normally closed, internal drain
23 L/min (6 USgpm) • 210 bar (3000 psi)

Model code

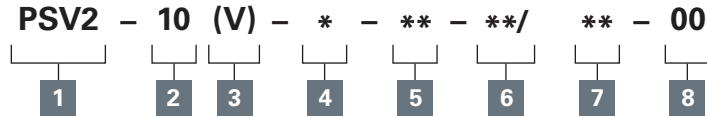

1 Function

PSV2 - Pressure sequence valve

2 Size

10 - 10 size

3 Seal material

Blank - Buna-N
V - Viton®

4 Adjustment

C - Cap
F - Factory set
I - Internal
K - Knob
S - Screw

5 Port size

0 - Cartridge only

Code	Port size	Housing number	
		Aluminum light duty	Aluminum fatigue rated
3B	3/8" BSPP	02-173358	-
6T	SAE 6	566162	-
2G	3/4" BSPP	-	876705
3G	3/8" BSPP	-	876714
6H	SAE 6	-	876704
8H	SAE 8	-	876711

See section J for housing.

6 Sequence pressure range

Note: Code based on pressure in psi.

2 - 3,5-14 bar (50-200 psi)

6 - 7-40 bar (100-600 psi)

12 - 14-80 bar (200-1200 psi)

24 - 25-165 bar (400-2400 psi)

7 Setting pressure

Within ranges in **6**

Blank - Normal factory setting at approximate mid-range. User requested settings in 3,45 bar (50 psi) steps, Coded as in the following examples:
10 - 70 bar (1000 psi)
10.5 - 72,4 bar (1050 psi)

8 Special features

00 - None
(Only required if valve has special features, omitted if "00.")

Dimensions

mm (inch)

Torque cartridge in housing
47-54 Nm (35-40 ft. lbs)

Cartridge only

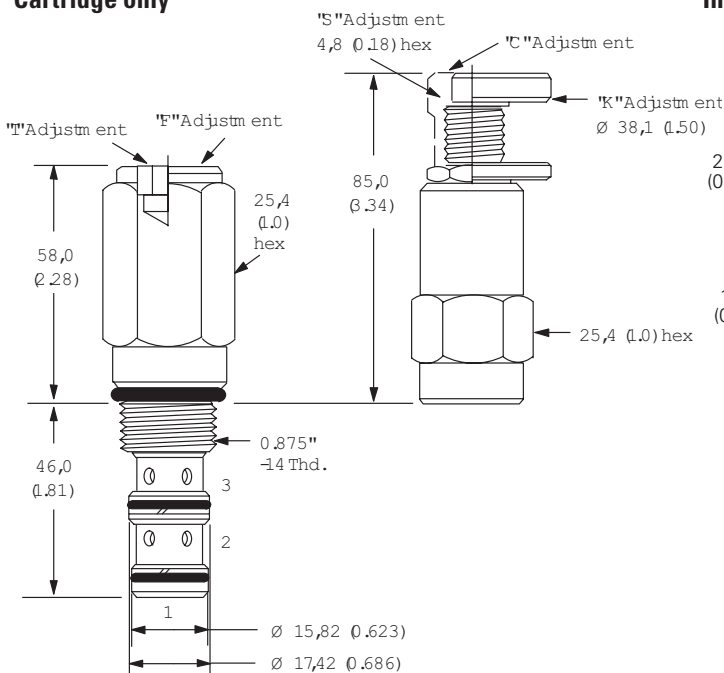

Installation drawing

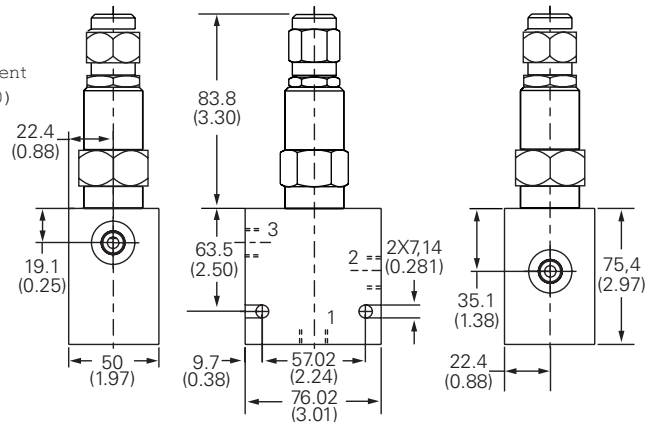

Warning

Aluminum housings can be used for pressures up to 210 bar (3000 psi). Steel housings must be used for operating pressures above 210 bar (3000 psi).

Where measurements are critical request certified drawings. We reserve the right to change specifications without notice.