

PSV10-10 - Pressure sequence valve

Spool direct acting, normally open, external drain
 23 L/min (6 USgpm) • 210 bar (3000 psi)

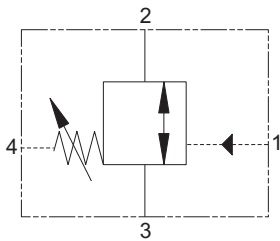

Operation

When a pre-set pilot pressure is reached the spool moves back against the spring opening the line between inlet and outlet.

When the pilot pressure falls the valve will return to its normal position.

Features

Cartridge design enabling speedy servicing when mounted in a body or in a composite manifold.

Sectional view

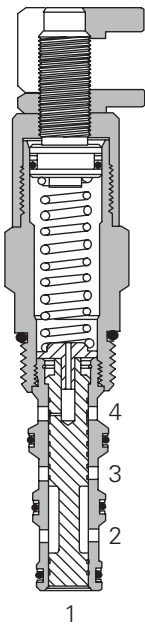

Performance data

Ratings and specifications

Performance data is typical with fluid at 21,8 cSt (105 SUS) and 49° C (120° F)

Typical application pressure (all ports)	210 bar (3000 psi)
Cartridge fatigue pressure (infinite life)	210 bar (3000 psi)
Maximum sequence pressure	165 bar (2400 psi)
Rated flow	23 L/min (6 USgpm)
Cavity	C-10-4
Standard housing materials	Aluminum
Temperature range	-40° to 120°C (-40° to 248°F)
Fluids	All general purpose hydraulic fluids such as: MIL-H-5606, SAE 10, SAE 20, etc.
Filtration	Cleanliness Code 18/ 16/13
Weight cartridge only	0,27 kg (0.60 lbs)
Seal kits	889625 Buna-N 566080 Viton®

Viton is a registered trademark of E.I. DuPont

⚠ Caution

When sudden pressure or velocity is applied at port 1, an orifice disc may be required.

Description

This valve provides a means of opening a pressure line when a predetermined pilot pressure is reached in a normally closed form.

The valve can be used in any pilot or small flow system as a remotely operated sequence valve.

Pressure drop curve

Port 3 to 2,
 valve fully open,
 spring omitted
 Cartridge only

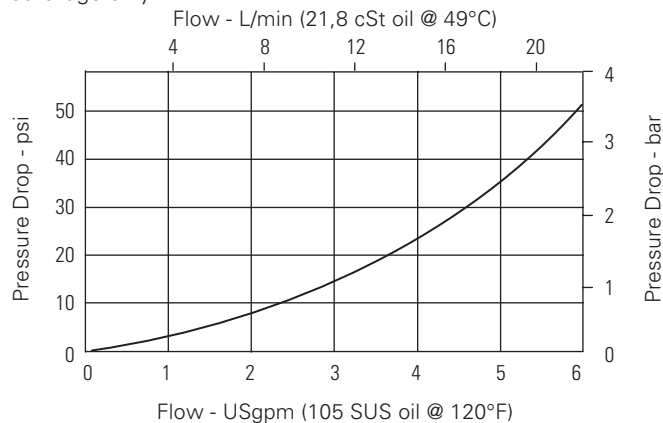

Where measurements are critical request certified drawings. We reserve the right to change specifications without notice.

PSV10-10 - Pressure sequence valve

Spool direct acting, normally closed, external drain
23 L/min (6 USgpm) • 210 bar (3000 psi)

Model code

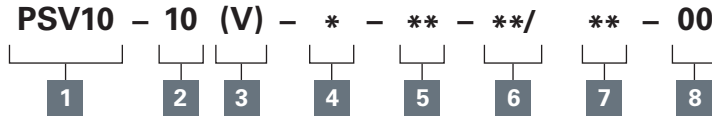

1 Function

PSV10 - Pressure sequence valve

2 Size

10 - 10 size

3 Seal material

Blank - Buna-N
V - Viton®

4 Adjustment

C - Cap
F - Factory set
I - Internal
K - Knob
S - Screw

5 Port size

0 - Cartridge only

Code	Port size	Housing number	
		Aluminum light duty	Aluminum fatigue rated
3B	3/8" BSPP	02-179705	-
6T	SAE 6	566161	-
2G	1/4" BSPP	-	876709
3G	3/8" BSPP	-	876715
6H	SAE 6	-	876708
8H	SAE 8	-	876713

See section J for housing.

6 Sequence pressure range

Note: Code based on pressure in psi.

2 - 3,5-14 bar (50-200 psi)
4 - 5-28 bar (75-400 psi)

6 - 7-40 bar (100-600 psi)
12 - 14-80 bar (200-1200 psi)
24 - 28-165 bar (400-2400 psi)

7 Setting pressure

Within ranges in **6**

Blank - Normal factory setting at approximate mid-range. User requested settings in 3,45 bar (50 psi) steps, Coded as in the following examples:

10 - 70 bar (1000 psi)
10.5 - 72,4 bar (1050 psi)

8 Special features

00 - None
(Only required if valve has special features, omitted if "00.")

Dimensions

mm (inch)

Torque cartridge in housing
47-54 Nm (35-40 ft. lbs)

Cartridge only

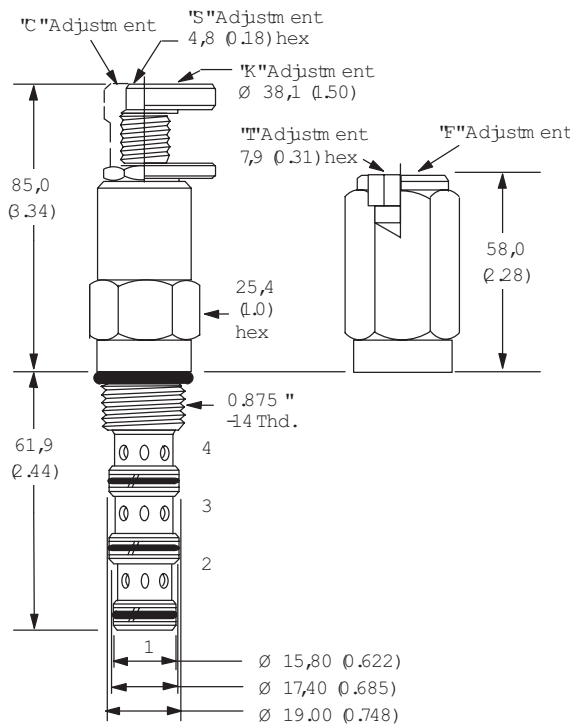

Installation drawing

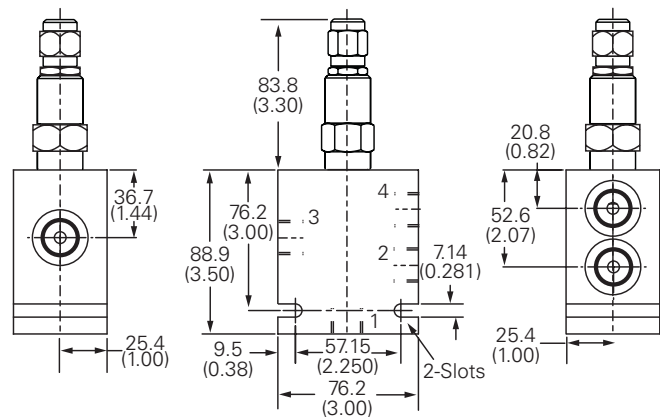

Where measurements are critical request certified drawings. We reserve the right to change specifications without notice.