

1PUL60 - Relief/unloading valve

Spool, pilot operated
60 L/min (16 USgpm) • 350 bar (5000 psi)

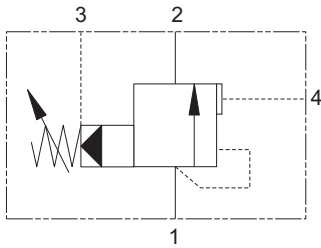

Operation

Inlet pressure is seen on the nose of the valve and system pressure (downstream of the system check valve) operates on the system pilot port. When pressure rises to the valve setting, the relief section opens and the system pressure acts on the pilot piston to hold the valve in the open position.

The ratio between the pilot piston diameter and the seat diameter to the relief valve pilot section ensures that the valve will be maintained in the fully open position until the system pressure drops to approximately 85% of the unload pressure.

Features

Valves are available as cartridges for installation into special line bodies or into custom designed Hydraulic Integrated Circuits. (NOTE: Provision must be made for a system check valve and a pilot line to signal the system pressure). Valve assemblies can be supplied complete in a line body for use in accumulator circuits. Bodied valves include a check valve and the required connection from the system to the valve pilot port.

Sectional view

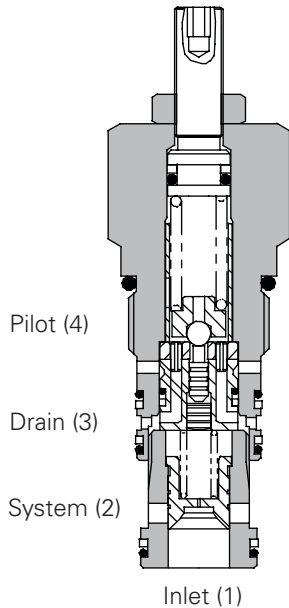

Performance data

Ratings and specifications

Figures based on: Oil Temp = 40° C Viscosity = 32 cSt (150 SUS)

Rated flow	60 L/min (16 USgpm)	
Max setting	350 bar (5000 psi)	
Differential Unload/Reload	10-15%	
Cartridge material	Working parts hardened and ground steel. External surfaces zinc plated.	
Body material	Standard steel	
Mounting position	Unrestricted	
Cavity number	A12088 (See Section M)	
Torque cartridge into cavity	75 Nm (55 lbs ft)	
Weight	1PUL60	0.46 kg (1.01 lbs)
	1PUL65	0.8 kg (1.76 lbs)
Seal kit number	1PUL60	SK750 (Nitrile), SK750V (Viton®)
Recommended filtration level	BS5540/4 Class 18/13 (25 micron nominal)	
Operating temp	-30° to +90°C (-22° to +194°F)	
Leakage	35 milliliters/min nominal	
Nominal viscosity range	5 to 500 cSt	

Viton is a registered trademark of E.I. DuPont

Description

These unloader valves are used to unload a pump, or pumps, to tank when pressure in a separate part of the circuit reaches a preset level. The valves will close, causing the circuit to reload, when the pressure drops to approximately 85% of the unload pressure. The most common application is to maintain a pressure in an accumulator which may be used in an emergency to operate an essential hydraulic function. (Eg, a brake circuit). The 1PUL60 valve has a drain port to ensure correct valve function while allowing the bypassed oil to be used for a secondary circuit requirement.

Pressure drop curves

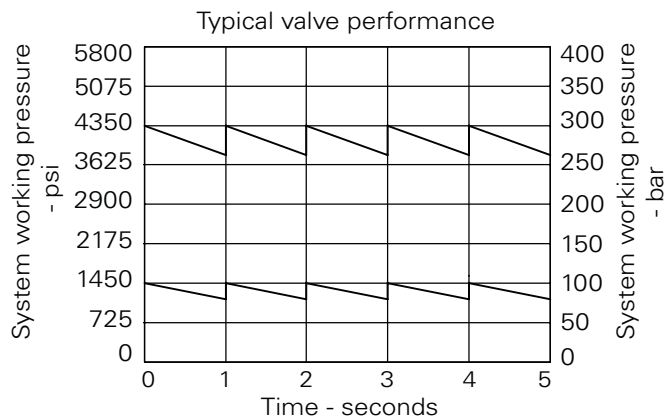

Where measurements are critical request certified drawings. We reserve the right to change specifications without notice.

1PUL60 - Relief/unloading valve

Spool, pilot operated
60 L/min (16 USgpm) • 350 bar (5000 psi)

Model code

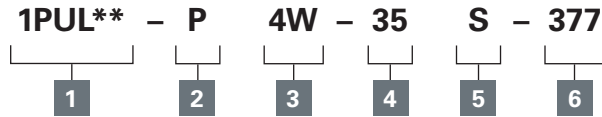

1 Function

1PUL60 - Cartridge only
1PUL6 - Cartridge and body

2 Adjustment means

P - Leakproof screw adjustment
G - Tamperproof cap
(See page E-7 for dimensions)

3 Port sizes

Code	Port size	Housing number - Sub Assembly	
		Aluminium	Steel
4W	1/2" BSP		BXP4046-4W-S-377
8T	1/2" SAE	BXP24046-8T-S	

4 Pressure range @ 4.8 L/min

Note: Code based on pressure in bar.
10 - 40-100 bar. Std setting 75 bar
20 - 70-210 bar. Std setting 100 bar
35 - 50-350 bar. Std setting 200 bar

5 Seals

S - Nitrile (for use with most industrial hydraulic oils)
SV - Viton (For high temperature and most special fluid applications)

6 Body material

377 - Steel
Omit for aluminium (up to 210 bar)

Dimensions

mm (inch)

Cartridge only

Basic Code
1PUL60

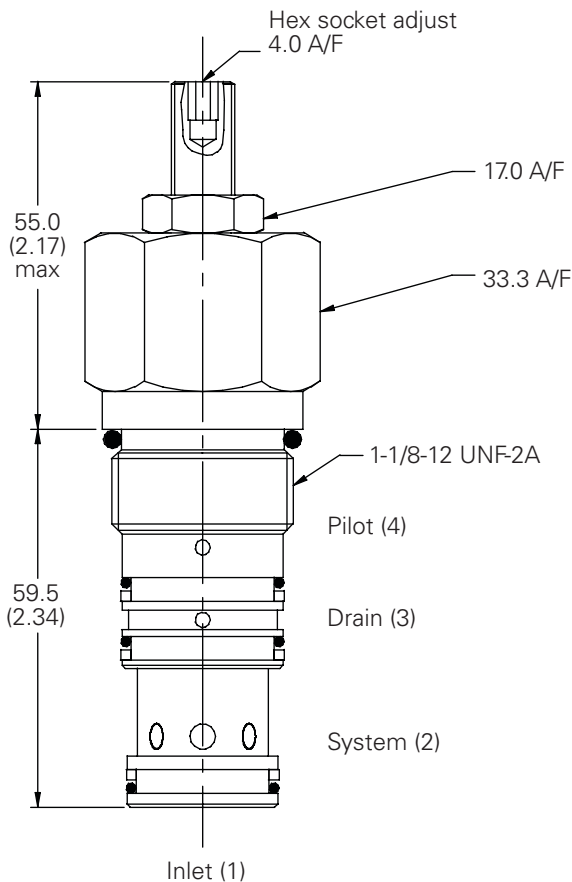

Note: For applications above 210 bar (3000 psi) please consult over technical department or use the steel body option.

Cartridge only

1/2" Ports
Basic Code
1PUL65
With System Check

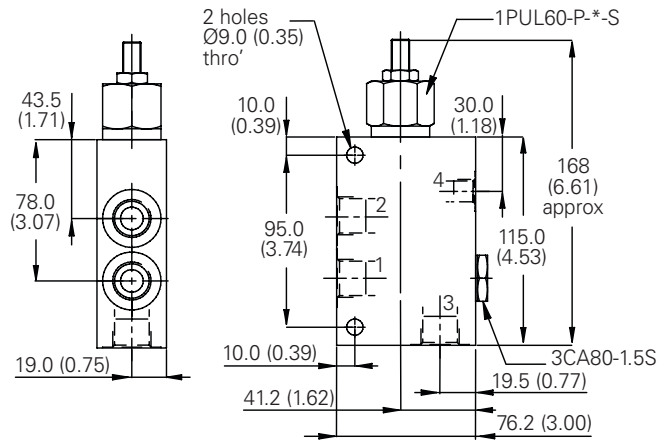

Typical Connections
Port 1 Pressure
Port 2 System
Port 3 Accumulator
Port 4 Drain

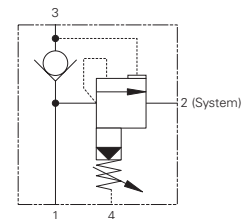

Where measurements are critical request certified drawings. We reserve the right to change specifications without notice.