

DSB*

SELF-REVERSING VALVE

SERIES 10

MOUNTING SURFACES

DSB3 ISO 4401-03 (CETOP 03)

DSB5 ISO 4401-05 (CETOP 05)

p max (see performances table)

Q nom (see performances table)

OPERATING PRINCIPLE

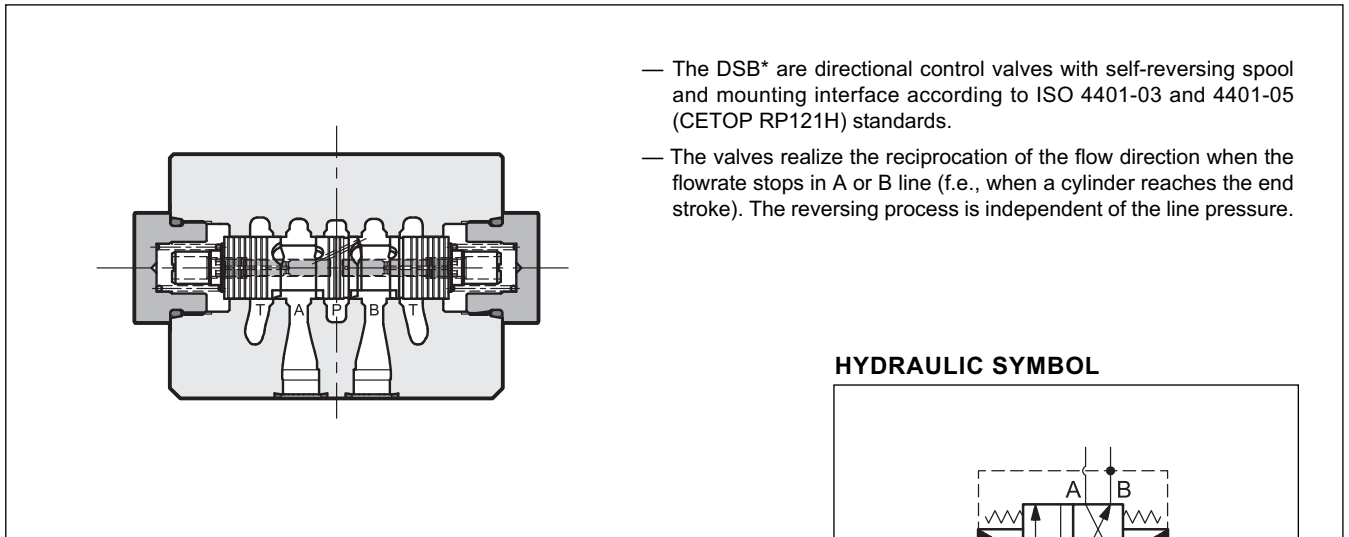

- The DSB* are directional control valves with self-reversing spool and mounting interface according to ISO 4401-03 and 4401-05 (CETOP RP121H) standards.
- The valves realize the reciprocation of the flow direction when the flowrate stops in A or B line (f.e., when a cylinder reaches the end stroke). The reversing process is independent of the line pressure.

HYDRAULIC SYMBOL

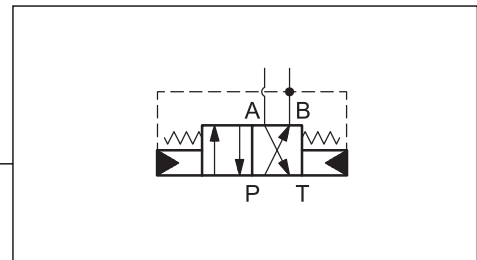

PERFORMANCES

(measured with mineral oil of viscosity 36 cSt at 50°C)

		DSB3	DSB5
Maximum operating pressure on port P	bar	350	320
Minimum allowed pressure	bar	50	60
Maximum flow rate	l/min	30	100
Minimum allowed flow rate	l/min	3	10
Ambient temperature range	°C	-20 / +50	
Fluid temperature range	°C	-20 / +80	
Fluid viscosity range	cSt	10 + 400	
Recommended viscosity	cSt	25	
Fluid contamination degree		according to ISO 4406:1999 class 20/18/15	
Mass	kg	0,9	2,8
Surface finishing		zinc-nickel surface treatment	

1 - IDENTIFICATION CODE

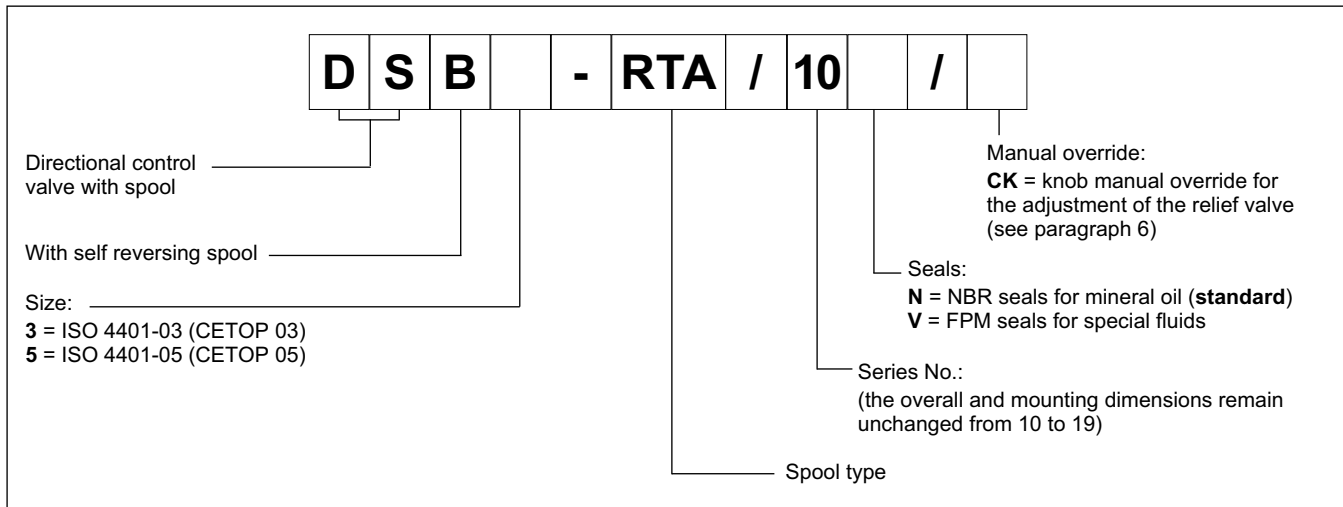

2 - PRESSURE DROPS Δp -Q

(values obtained with viscosity 36 cSt at 50 °C)

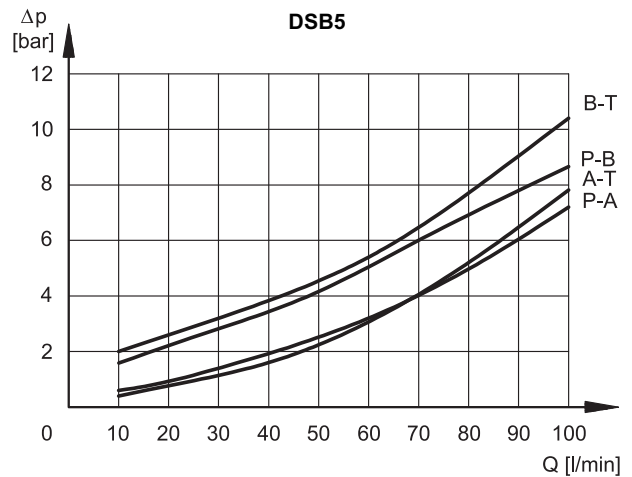
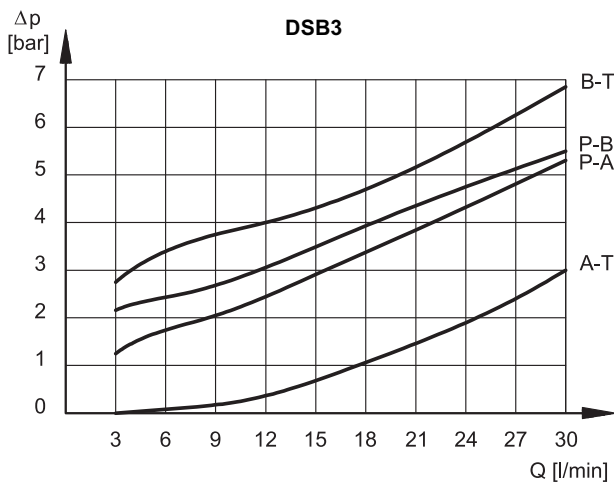

3 - HYDRAULIC FLUIDS

Use mineral oil-based hydraulic fluids HL or HM type, according to ISO 6743-4. For these fluids, use NBR seals. For fluids HFDR type (phosphate esters) use FPM seals (code V). For the use of other kinds of fluid such as HFA, HFB, HFC, please consult our technical department.

Using fluids at temperatures higher than 80 °C causes a faster degradation of the fluid and of the seals characteristics. The fluid must be preserved in its physical and chemical characteristics.

5 - OVERALL AND MOUNTING DIMENSIONS DSB3

dimensions in mm

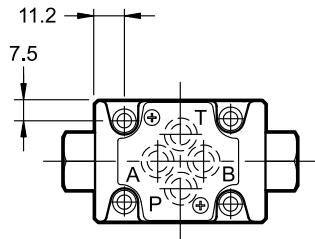
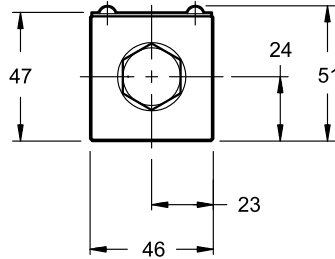
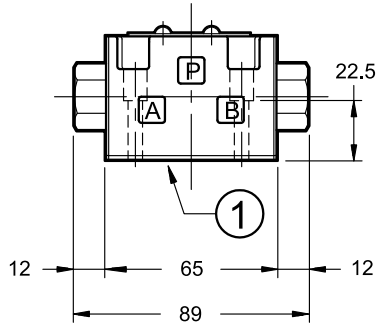

MOUNTING INTERFACE

ISO 4401-03-02-0-05
(CETOP 4.2-4-03-350)

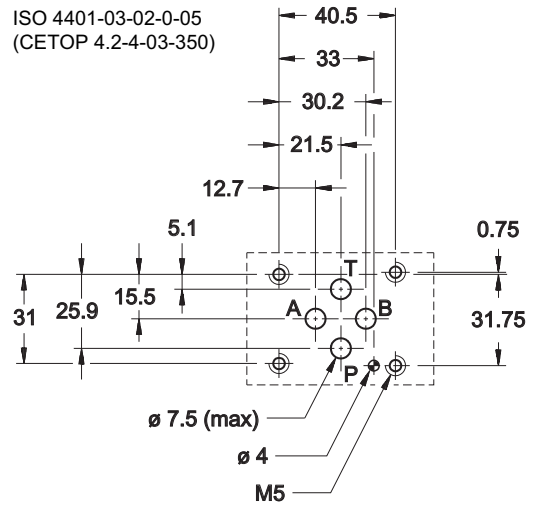

Valve fastening: N. 4 bolts SHC M5x30 - ISO 4762
Tightening torque: 5 Nm (bolts A 8.8)
Threads of mounting holes: M5x10

1	Mounting surface with sealing rings: N. 4 OR type 2037 (9.25x1.78) 90 shore
---	-----------------------------------------------------------------------------------

5 - OVERALL AND MOUNTING DIMENSIONS DSB5

dimensions in mm

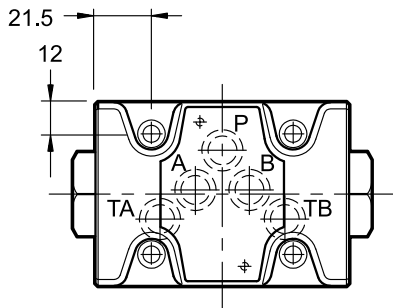
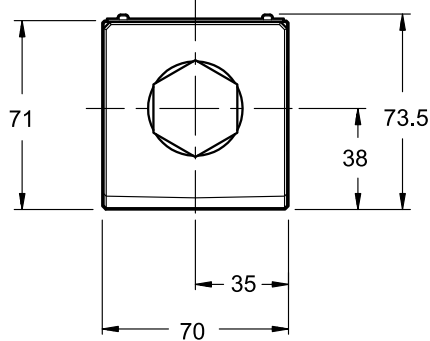
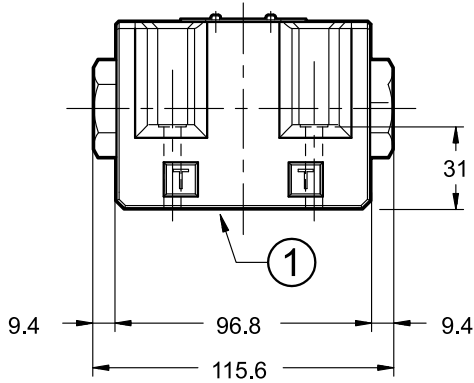

MOUNTING INTERFACE

ISO 4401-05-04-0-05
(CETOP 4.2-4-05-320)

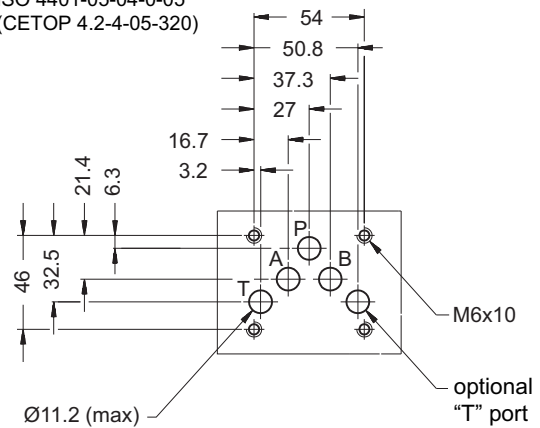

Valve fastening: N. 4 bolts SHC M6x40 - ISO 4762

Tightening torque: 8 Nm (bolts A 8.8)

Threads of mounting holes: M6x10

1 Mounting surface with sealing rings:
N. 5 OR type 2050 (12.42x1.78)
90 shore

6 - KNOB MANUAL OVERRIDE

The knob manual override **CK** allows to set the pressure of the relief valve without using shut-off valves.

CK for DSB3

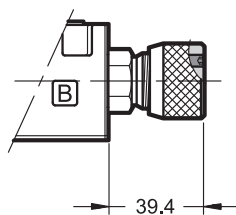

Allen key for set screw: 2,5 mm

CK for DSB5

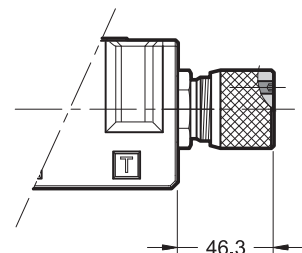

Allen key for set screw: 3 mm

7 - INSTALLATION

The valves can be mounted in any position. Valve fixing is by means of screws or tie rods, with the valve mounted on a lapped surface, with values of planarity and smoothness that are equal to or better than those indicated in the drawing.

If the minimum values of planarity and/or smoothness are not met, fluid leakage between valve and mounting surface can easily occur.

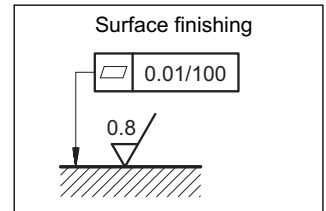

We suggest to use the circuits shown, connecting the A port with the rear chamber of the cylinder. In this way, with the start of the pump, the valve places itself, so as to retract the rod. To work properly the valve needs an area ratio of the cylinder chambers included between 1:1,25 and 1:2.

7.1 - Standard valve

To set the system relief valve correctly, the self-reversing function must be inactive.

To do so, close the shut-off valve, start the pump, set the pressure relief valve and stop the pump. Then, open the shut-off valve and restart the pump.

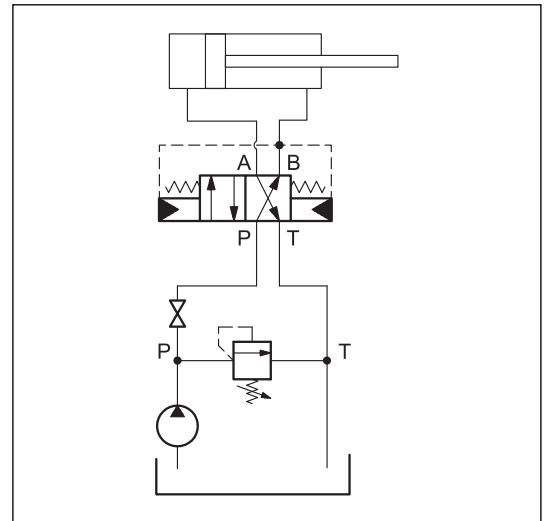

7.2 - Valve with knob manual override

To set the system relief valve correctly, the self-reversing function must be inactive.

To do so, completely unscrew the set screw then tighten the knob until it is at mechanical stop. The spool is now clamped in position P → B and A → T. Start the pump, set the pressure of the relief valve and then stop the pump. Re-establish the working conditions of the valve, unscrewing almost completely the knob and screwing the set screw, until its point is aligned with the edge of the knob.

The valve is in normal working conditions when the knob is tightened and the point of the set screw is aligned with the edge of the knob.



Do not use the manual override when the valve is on: if it is necessary stop the pump.

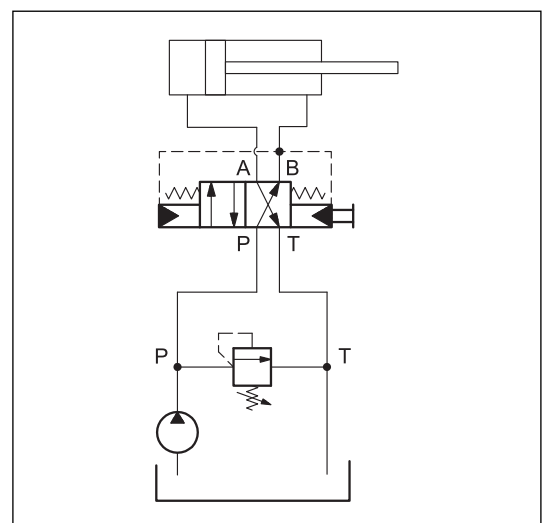



8 - SUBPLATES (see catalogue 51 000)

	DSB3	DSB5
Type with rear ports	PMMD-AI3G	PMD4-AI4G - 3/4" BSP threaded
Type with side ports	PMMD-AL3G	PMD4-AL4G - 1/2" BSP threaded
Threading of ports P, T, A, B	3/8" BSP	-



DIPLOMATiC OLEODiNAMiCA S.p.A.
20015 PARABIAGO (MI) • Via M. Re Depaolini 24
Tel. +39 0331.895.111
Fax +39 0331.895.339
www.diplomatic.com • e-mail: sales.exp@diplomatic.com

