



M63

PRESSURE GAUGE

SERIES 10

according to EN 837-1

TECHNICAL CHARACTERISTICS

Nominal diameter	mm	63
Nominal pressure	bar	0 ÷ 6 0 ÷ 10 0 ÷ 16 0 ÷ 25 0 ÷ 60 0 ÷ 100 0 ÷ 160 0 ÷ 250 0 ÷ 400
Static pressure	3/4 of the end scale value	
Dynamic pressure	2/3 of the end scale value	
Limit pressure	end scale value for short period	
Precision class according to EN 837-1	1,6	
Thermal drift	± 0,4% / 10K in the measure range	
Protection class according to EN 60529 / IEC 60529	IP65	
Ports according to EN 837-1	1/4" BSP	
Ports material	copper alloy	
Sensible element: 0 ÷ 6, 0 ÷ 10, 0 ÷ 16, 0 ÷ 25, 0 ÷ 60. 0 ÷ 100, 0 ÷ 160, 0 ÷ 250, 0 ÷ 400.	copper alloy, type-C, braze welding spring copper alloy, helical, braze welding spring	
Movements	copper alloy	
Dial	white plastic with lock pins in black plastic	
Case	stainless steel with natural finishing, and OR between case and shank	
Display	transparent plastic	
Filling liquid	glycerin 85% + distilled water 15%	
CE Marking	in compliance with PED 2014/68/EU	
Working temperature range	°C	-20 / +60
Mass	kg	0,24

DESCRIPTION

- The pressure gauges M63 are pressure indicators used on hydraulic systems.
- They guarantee a correct pressure measurement also with pulsations and vibrations.
- They are available in 9 different pressure scales and with 2 connection types for mounting with radial port or rear port with flange connector.
- The case is made of stainless steel and the connection is made of copper alloy.
- The filling in liquid is made of 85% glycerin and 15% distilled water.
- The pressure gauges with a end scale of 250 bar and 400 bar are equipped with the CE mark on the dial for the fluid group 1 according to Annex II, scheme 1 of the PED directive 2014/68/EU. All the others do not need the CE marking, as per art. 4, sec. 3 of the same directive.
- The construction and the realisation have been done according to EN 837-1.

HYDRAULIC SYMBOL

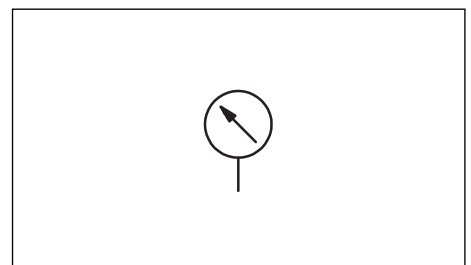

1 - IDENTIFICATION CODE

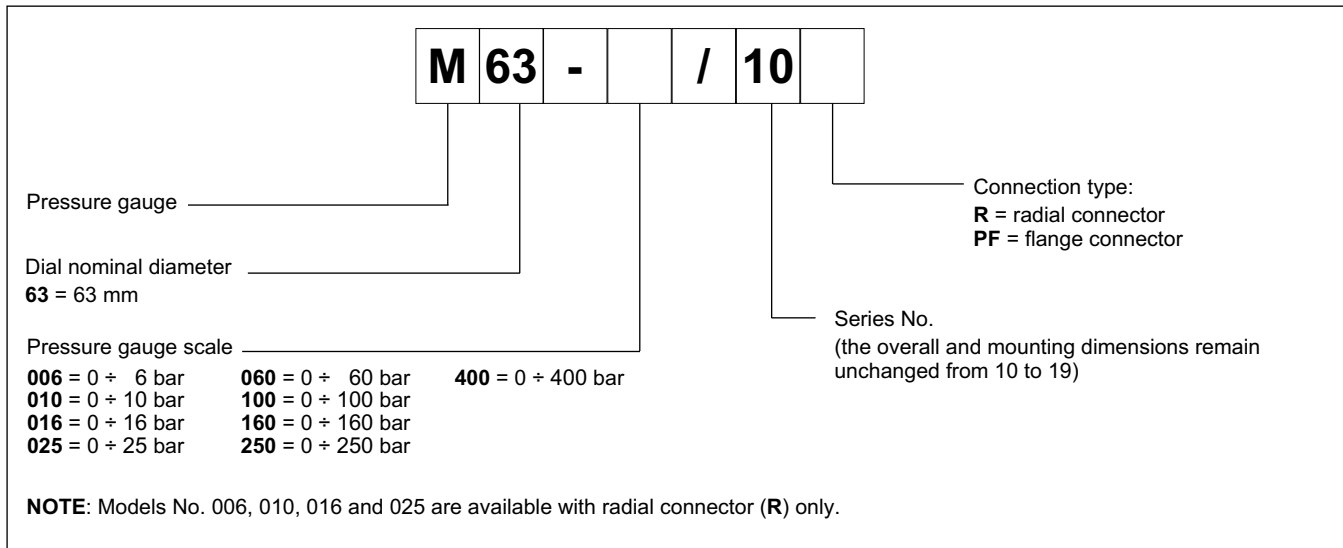

2 - OVERALL AND MOUNTING DIMENSIONS

