

General Description

Series 620 - 649 in-line pressure control valves open the system to tank when the system pressure reaches the pressure setting of the control valve. The pressure setting is externally adjustable so that it can be tuned accordingly within its range. However, the valve can be factory set to a specified pressure setting.

Specifications

Service App.	Hydraulic and Pneumatic
Maximum Operating Pressure	Working: 0.3 to 248.4 Bar (4 to 3600 PSI) in 13 ranges Reset: Range 1: 80% of cracking press. Ranges 2 - 13: 90% of cracking pressure
Sizes	NPT 1/4", 1/2", 3/4" IST SAE 6, SAE 10, SAE 12 FLD SAE 6, SAE 10, SAE 12
Ports	NPT Pipe threads IST Internal straight threads FLD Flared Tube Connection SAE 37°
Material	Body, Cap Brass, aluminum alloy, stainless steel Finish Aluminum alloy, anodized; stainless steel Poppet 416 Stainless Steel (Hard seat) 303 Stainless Steel (Soft seat) Seat (soft) Ranges 1 -3: Synthetic rubber - Code 2 Ranges 4 - 13: PTFE Spring Stainless steel Cap O-ring Synthetic rubber
Operating Temperature	-40°C to +121°C (-40°F to +250°F) Higher on special order

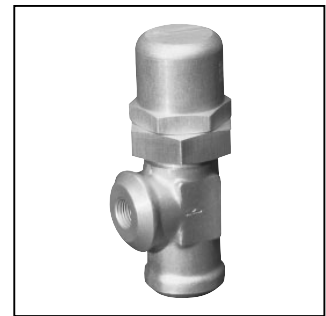
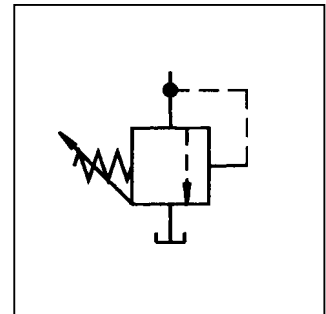
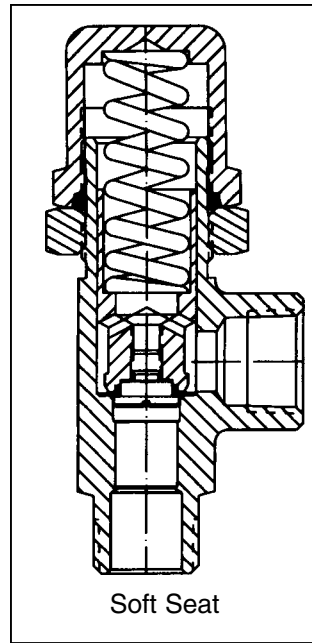

Hard Seat
 available only in
 Brass and Stainless Steel

Features

- Externally adjustable.
- Available for hydraulic or pneumatic service.
- Quick response for venting applications.

Dimensions

Inch equivalents for millimeter dimensions are shown in (**)

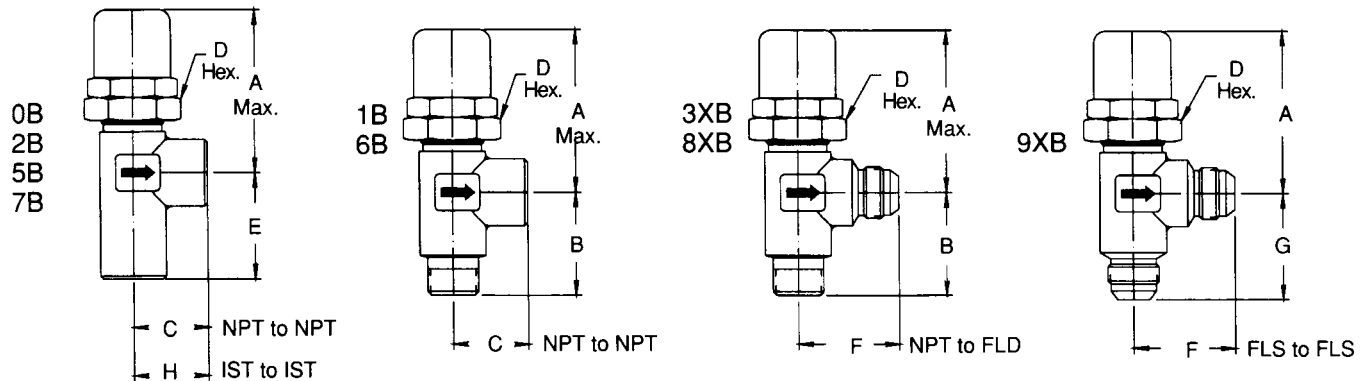

Valve Size		Dimensions								Maximum Rated Flow LPM (GPM)	Weights (Approx.)		
Pipe	Tube	A	B	C	D	E	F	G	H		Allum. Alloy	Brass	Stainless Steel
1/4	6	60.3 (2.38)	34.9 (1.38)	27.0 (1.06)	31.8 (1.25)	32.5 (1.28)	36.5 (1.44)	38.1 (1.50)	27.0 (1.06)	15.1 (4.0)	4 oz.	10 oz.	12 oz.
1/2	10	94.5 (3.72)	54.0 (2.13)	38.1 (1.50)	44.5 (1.75)	54.8 (2.16)	52.4 (2.06)	55.6 (2.19)	38.1 (1.50)	37.9 (10.0)	14 oz.	2 lbs. 2 oz.	2 lbs. 4 oz.
3/4	12	94.5 (3.72)	54.0 (2.13)	39.7 (1.56)	44.5 (1.75)	55.6 (2.19)	53.2 (2.09)	55.6 (2.19)	39.7 (1.56)	56.8 (15.0)	14 oz.	2 lbs. 2 oz.	2 lbs. 4 oz.

2502-H1.p65, dd

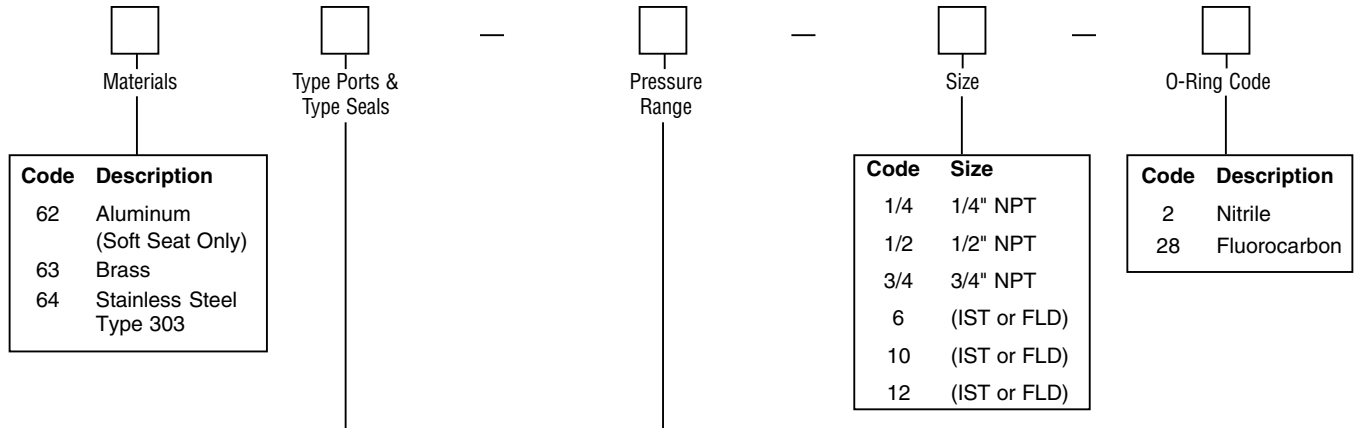

Code	Inlet	Outlet	Code	Inlet	Outlet
Hard Seat			Soft Seat		
0B	IST	IST	5B	IST	IST
1B	NPT	NPT	6B	NPT	NPT
2B	NPT	NPT	7B	NPT	NPT
3XB	NPT	FLD	8XB	NPT	FLD
			629XB	FLD	FLD only

Hard Seat available in Brass and Stainless Steel only.

Code	Description
1	0.3 - 1.0 Bar (4-15 PSI)
2	0.7 - 3.5 Bar (10-50 PSI)
3	2.8 - 8.6 Bar (40-125 PSI)
4	7.9 - 17.3 Bar (115-250 PSI)
5	16.2 - 31.1 Bar (235-450 PSI)
6	29.7 - 44.9 Bar (430-650 PSI)
7	43.5 - 58.7 Bar (630-850 PSI)
8*	43.5 - 70.4 Bar (630-1020 PSI)
9*	55.2 - 103.5 Bar (800-1500 PSI)
10*	96.6 - 144.9 Bar (1400-2100 PSI)
11*	103.5 - 189.8 Bar (1500-2750 PSI)
12*	138.0 - 213.9 Bar (2000-3100 PSI)
13*	207.0 - 248.4 Bar (3000-3600 PSI)

* Hard Seat only.

PTFE seats for Ranges 4, 5, 6 and 7 only.

Pressure Range

Range Bar (PSI)	Pre-Set Cracking Pressure	Soft Seat Material (when used)	Range Dash Number
0.3 - 1.0 Bar (4-15 PSI)	0.7 Bar (10 PSI)	Synthetic Rubber	-1
0.7 - 3.5 Bar (10-50 PSI)	2.4 Bar (35 PSI)	Synthetic Rubber	-2
2.8 - 3.5 Bar (40-125 PSI)	6.2 Bar (90 PSI)	Synthetic Rubber	-3
7.9 - 17.3 Bar (115-250 PSI)	13.8 Bar (200 PSI)	PTFE	-4
16.2 - 31.1 Bar (235-450 PSI)	24.8 Bar (360 PSI)	PTFE	-5
29.7 - 44.9 Bar (430-650 PSI)	38.0 Bar (550 PSI)	PTFE	-6
43.5 - 58.7 Bar (630-850 PSI)	51.8 Bar (750 PSI)	PTFE	-7
43.5 - 70.4 Bar (630-1020 PSI)	58.7 Bar (850 PSI)	PTFE	-8
55.2 - 103.5 Bar (800-1500 PSI)	69.0 Bar (1000 PSI)	PTFE	-9
96.6 - 144.9 Bar (1400-2100 PSI)	120.8 Bar (1750 PSI)	PTFE	-10
103.5 - 189.8 Bar (1500-2750 PSI)	151.8 Bar (2200 PSI)	PTFE	-11
138.0 - 213.9 Bar (2000-3100 PSI)	179.4 Bar (2600 PSI)	PTFE	-12
207.0 - 248.4 Bar (3000-3600 PSI)	220.8 Bar (3200 PSI)	PTFE	-13

Definitions:

Cracking pressure – Liquid: 15 tp 20 DPM
 Air: steady stream of bubbles
 Reseat leakage – Less than 1 DPM or 1 BPM



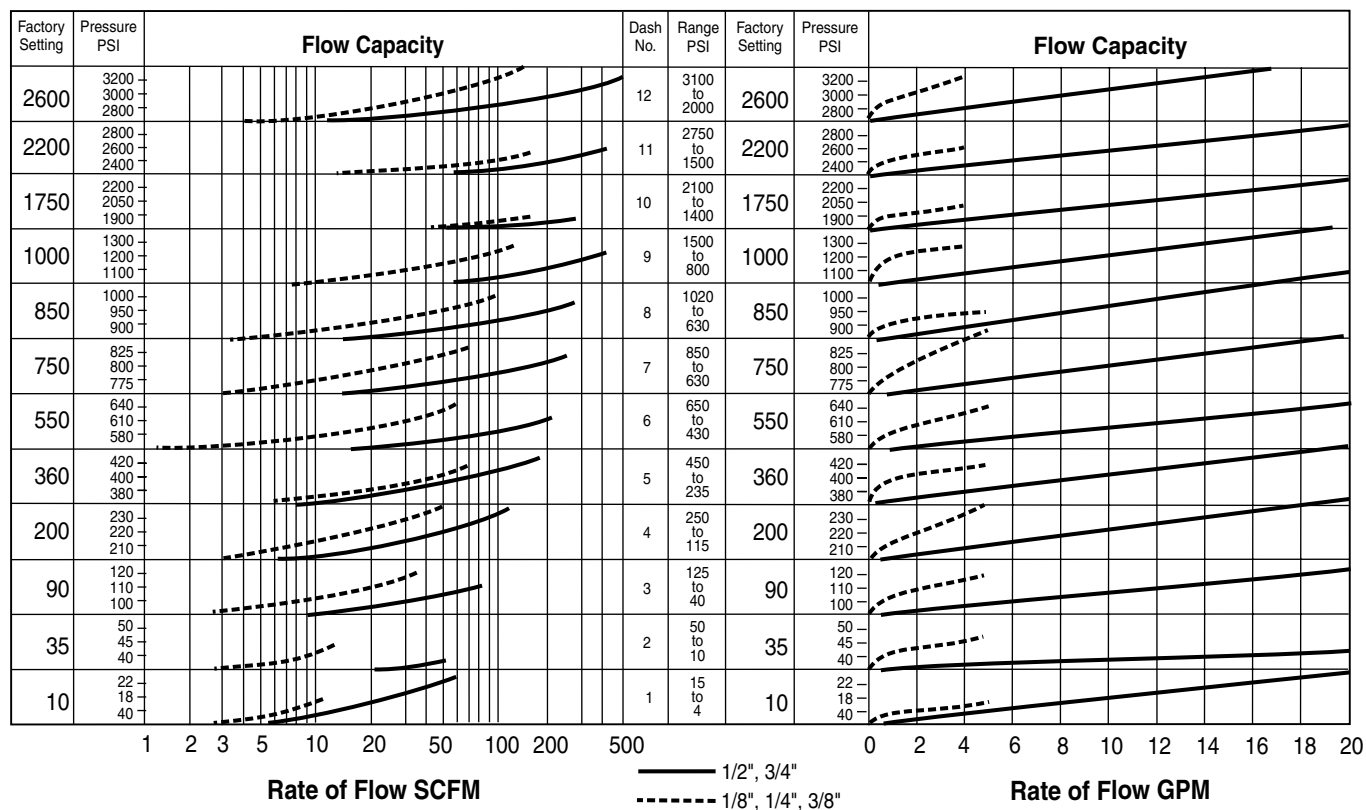

Examples

Pneumatic:

- Establish cracking pressure setting of 1/2" valve for flow of 70 SCFM at 27.6 Bar (400 PSI) pressure:
1. Project 70 SCFM on vertical scale.
 2. Project 27.6 Bar (400 PSI) scale horizontally intersecting 1.
 3. Project line parallel to curves back to vertical line 1.
 4. Read cracking pressure setting: 24.8 Bar (360 PSI).

Hydraulic:

- Find amount of pressure increase above 24.8 Bar (360 PSI) cracking pressure when flow through 3/4" valve is increased to 54 LPM (14 GPM):
1. From 360 on vertical pressure scale, follow 3/4" curve until it intersects with the vertical line representing 54 LPM (14 GPM).
 2. Project intersecting point horizontally and read pressure, i.e., 29 Bar (420 PSI).
 3. Accumulated Pressure:
 $420 \text{ minus } 360 = 4.1 \text{ Bar (60 PSI)}$.

