

**General Description**

Series ICP pilot-operated check valves allow free flow in one direction, and prevent any flow in the opposite direction until the pilot is actuated, allowing the valve to open and permit flow in the reverse direction.

**Features**

- One of two poppet ratios may be selected.
- The -19 poppet is 2-stage, which helps eliminate shock. It permits the use of lower pilot pressures.

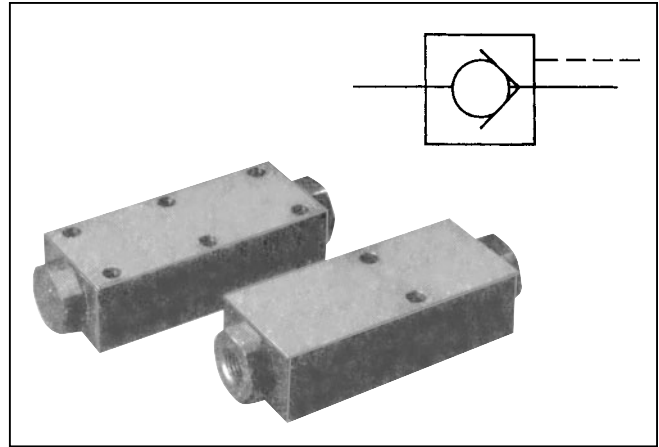

**Specifications**

<b>Maximum Operating Pressure</b>	210 Bar (3000 PSI)
<b>Nominal Flow</b>	30 LPM (8 GPM)
<b>Maximum Flow</b>	45 LPM (12 GPM)
<b>Poppet Styles</b>	Single stage: 3:1 area ratio Two stage, decompression: 19:1 area ratio
<b>Mounting</b>	In-line, in any position
<b>Material</b>	Steel



**Ordering Information**

Example: "ICP6003M—" means Model ICP, 3/8" NPTF 3:1 pilot piston area ratio, standard nitrile seal.

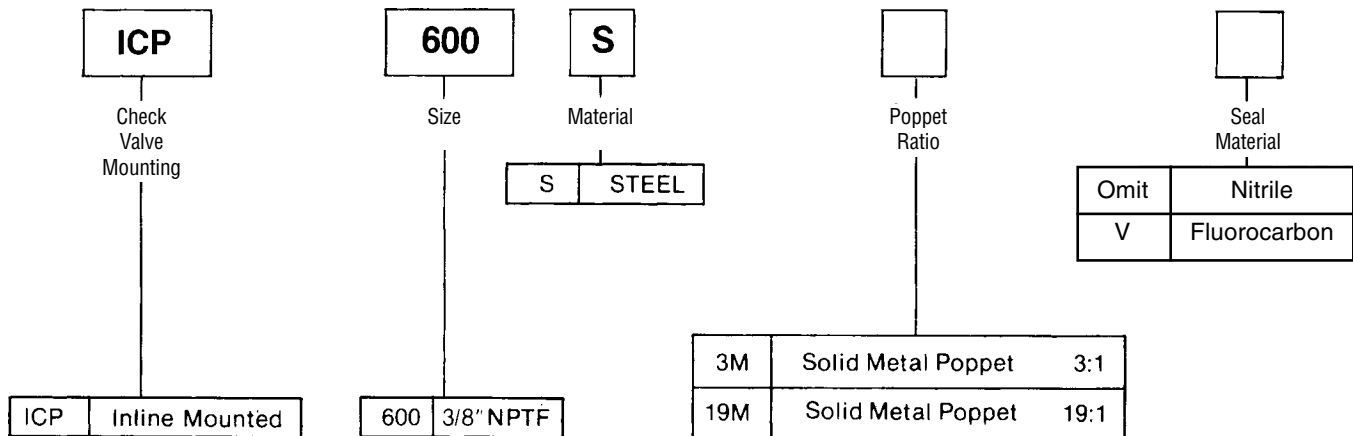

**Performance Curves**

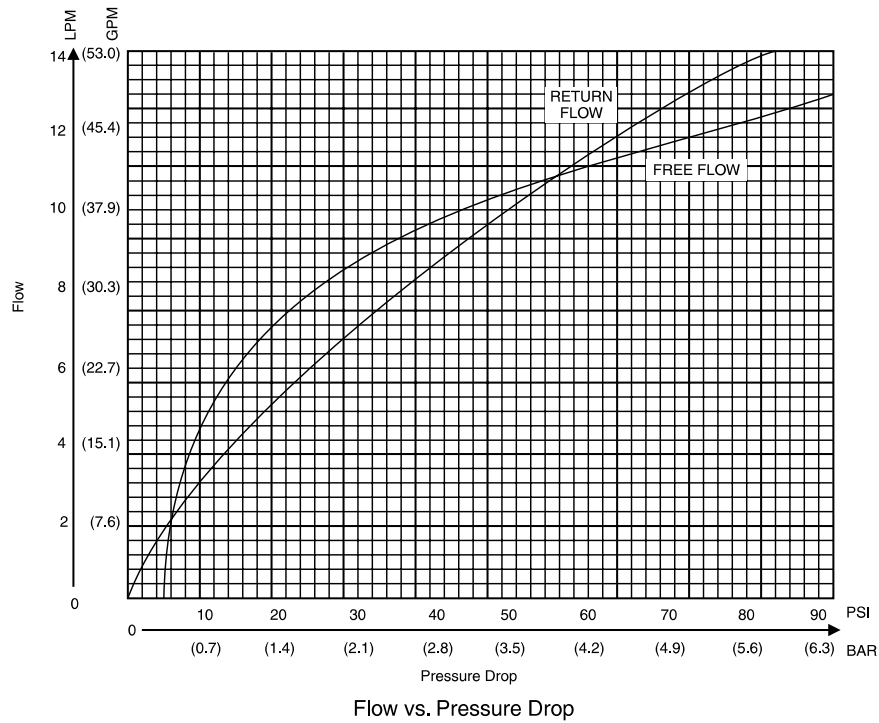

**Dimensions**

Millimeter equivalents for inch dimensions are shown in (\*\*)

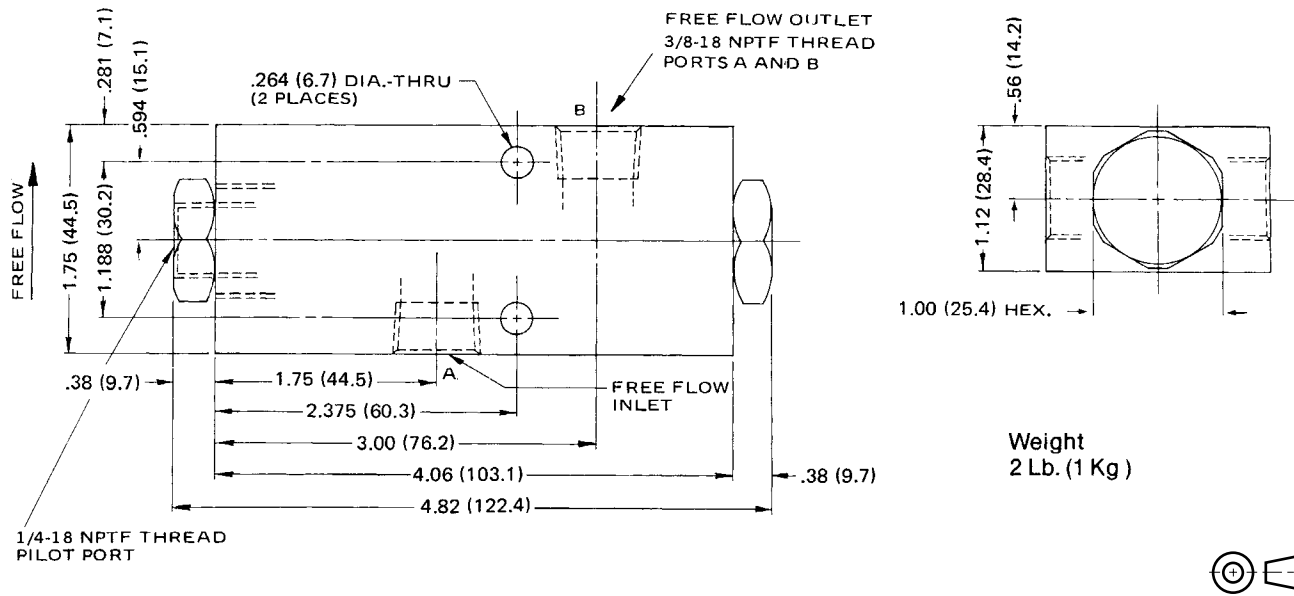

Valve Model	Port Size	Flow (Max) GPM (L/M)	Δ P @ Max Free Flow PSI (Bar)	Δ P @ Max Reverse Flow PSI (Bar)	Area Ratio	
					Pilot Piston Area To Decompression Poppet Area	Pilot Piston Area To Check Valve Area
ICP 600S3*	3/8 NPTF	12 (45.4)	78 (5.5)	60 (4.2)	—	3:1
ICP 600S19*	3/8 NPTF	12 (45.4)	78 (5.5)	60 (4.2)	19:1	3:1

2502-F1.p65, dd



**Contents**

**In-Line Mounted Flow Control Valves**

Series F ..... Flow Control ..... G2 - G5

Series 6F ..... Flow Control (Metric Ports) ..... G6 - G7

Series PC\*K ..... Pressure Compensated, Fixed ..... G8 - G10

Series PC\*M ..... Pressure Compensated, Adjustable ..... G11 - G13

Series N ..... Needle ..... G14 - G16

Series 6N ..... Needle (Metric Ports) ..... G17 - G18

Series MV ..... Metering ..... G19 - G22

Series 6MV ..... Metering (Metric Ports) ..... G23 - G24

Series 133, 135 and 143 ..... Needle ..... G25 - G26

Series S133, S135 and S143 ..... Needle, Soft Seat ..... G25 - G26

Series T143 - T148 ..... Toggle ..... G27

Series 154 ..... Needle, High Pressure ..... G28 - G29

Series 6611 ..... Flow Combiner / Divider ..... G30

Series FS ..... Flow Control ..... G31 - G35

Series PC\*MS ..... Pressure Compensated ..... G36 - G40

Series TPC ..... Temperature & Pressure Compensated ..... G41 - G45

Series FG3PKC ..... Temperature & Pressure Compensated ..... G46 - G49

Series MVI ..... Cartridge-type Needle ..... G50 - G53

Series D ..... Cam-Operated, 2-Way ..... G54 - G70

Series NS ..... Needle ..... G71 - G74

