

General Description

Series R5U pilot operated, pressure unloading valves have a similar design to the subplate mounted R4U series. The SAE flanges allow to mount the valve directly on the outlet flanges of pumps.

A typical application is the unloading of a pump in an accumulator circuit. The combination of an R5U, C5V and R5V on a double pump generates a high pressure / low pressure pump system without the need of a manifold block or piping between the valves.

Features

- Pilot operated unloading valve.
- 3-port body with SAE 61 flange.
- 4 sizes (SAE 3/4", 1", 1 1/4", 1 1/2").
- 3 pressure stages.
- 3 adjustment modes:
 - Hand knob
 - Acorn nut with lead seal
 - Key lock
- With optional vent function.

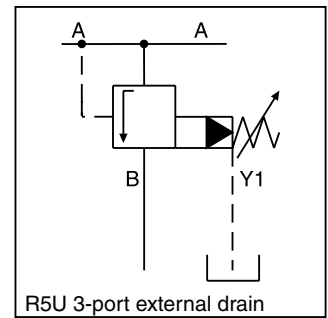
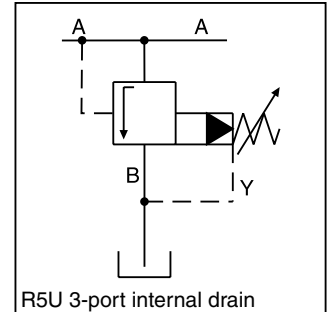

D

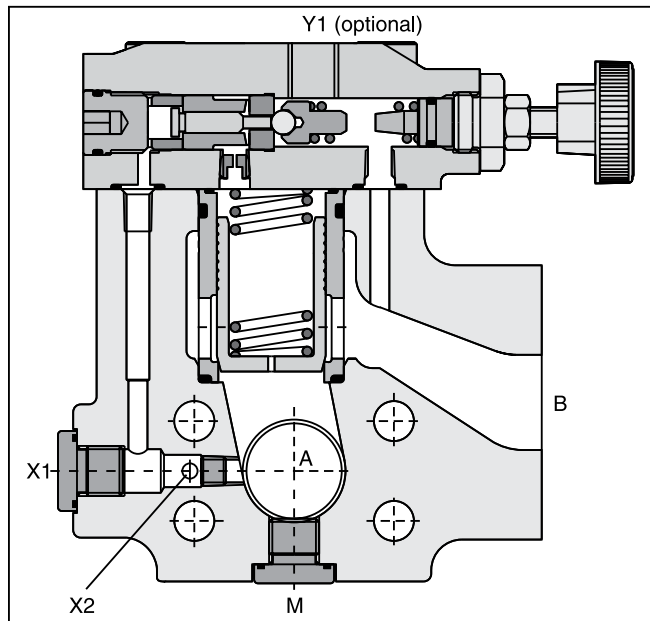

High Pressure / Low Pressure System

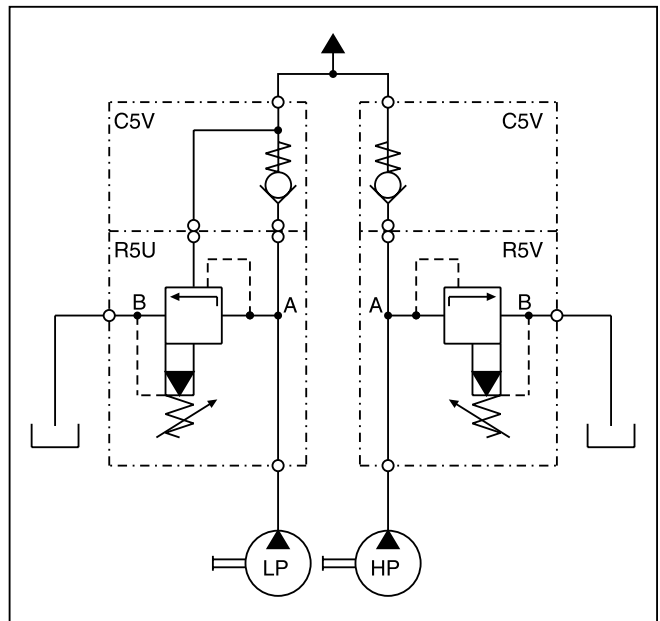

Ordering Information

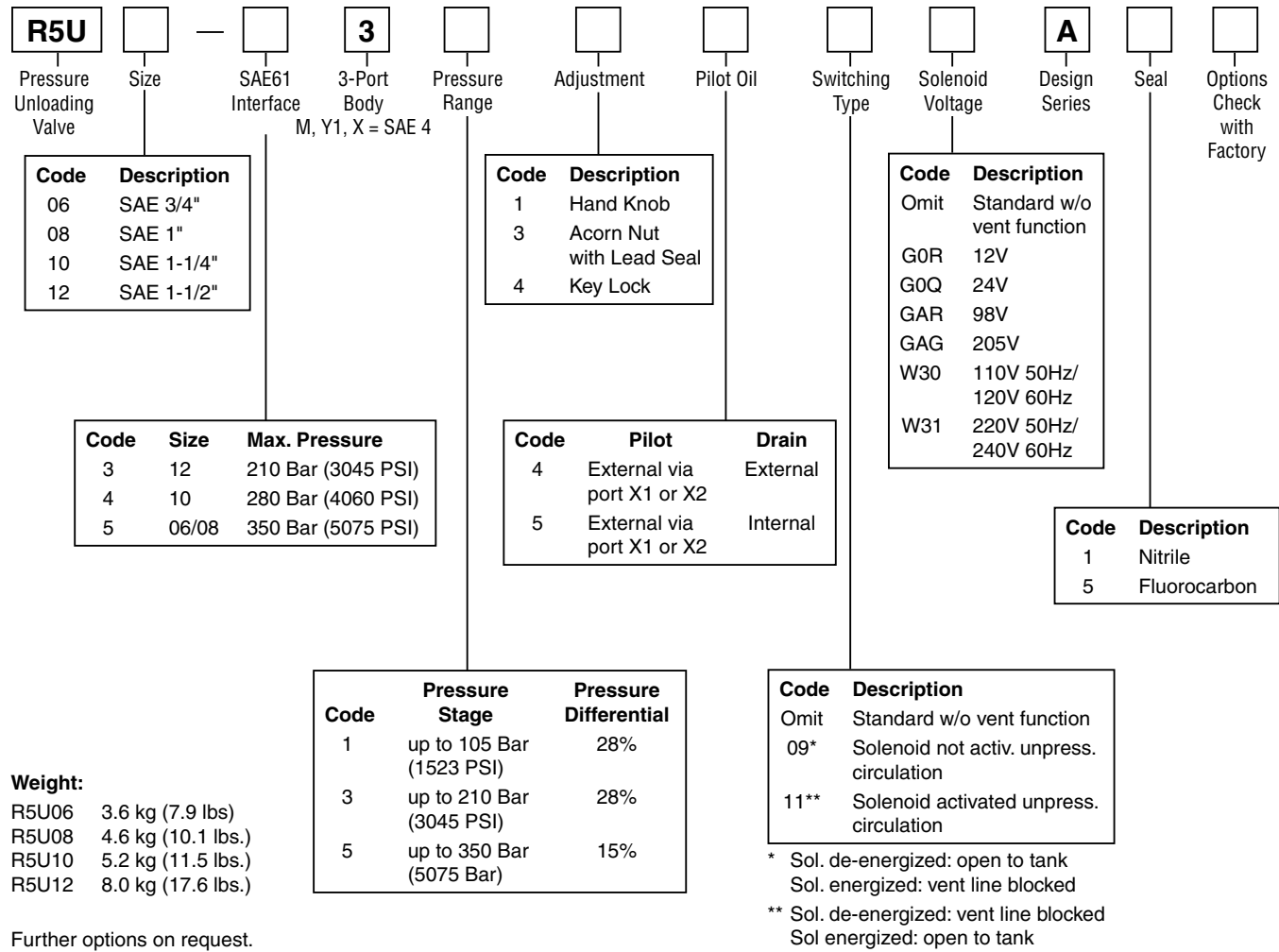

Performance Curves

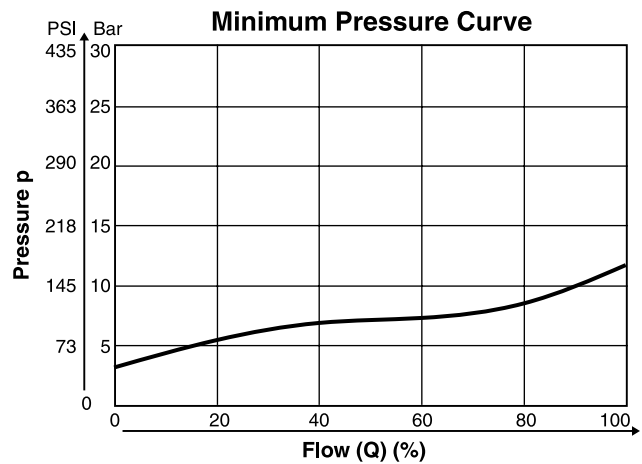
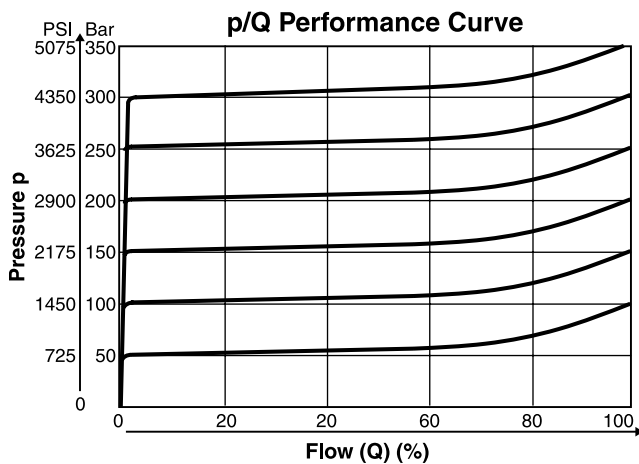

The performance curves are measured with external drain.
 For internal drain the tank pressure has to be added to curve.

R5U.indd, dd

General							
Size		06	08	10	12		
Mounting	Flanged according to SAE 61						
Mounting Position	Unrestricted						
Ambient Temperature	-20°C to +50°C (-4°F to +122°F)						
Hydraulic							
Maximum Operating Pressure	Ports A,B, X	350 Bar (5075 PSI)	350 Bar (5075 PSI)	280 Bar (4060 PSI)	210 Bar (3045 PSI)		
	Ports Y, Y1	30 Bar (435 PSI)	30 Bar (435 PSI)	30 Bar (435 PSI)	30 Bar (435 PSI)		
Pressure Ranges	105 Bar (1523 PSI), 210 Bar (3045 PSI), 350 Bar (5075 PSI)						
Nominal Flow		90 LPM (23.8 GPM)	300 LPM (79.4 GPM)	600 LPM (158.7 GPM)	600 LPM (158.7 GPM)		
Fluid	Hydraulic oil as per DIN 51524 ... 51525						
Fluid Temperature	-20°C to +80°C (-4°F to +176°F)						
Viscosity Permitted Recommended	10 to 650 cSt / mm ² /s (46 to 3013 SSU) 30 cSt / mm ² /s (139 SSU)						
Filtration	ISO Class 4406 (1999) 18/16/13 (acc. NAS 1638: 7)						
Electrical							
Duty Ratio	100%						
Solenoid Connection	Connector as per EN175301-803						
Protection Class	IP65 in accordance with EN60529 (plugged and mounted)						
Supply Voltage	Code	G0R	G0Q	GAR	GAG	W30	W31
		12V	24V	98V	205V	110V at 50Hz 120V at 60Hz	220V at 50Hz 240V at 60Hz
Tolerance Supply Voltage		+5 to -10	+5 to -10	+5 to -10	+5 to -10	±5	±5
Power Consumption	Hold	31W	31W	31W	31W	78W	78W
	In Rush	31W	31W	31W	31W	264W	264W
Response Time	Energized / De-energized AC 20/18ms, DC 46/27 ms						
Maximum Switching Frequency	AC up to 7200 switchings/hour DC up to 16,000 switchings/hour						
Coil Insulation Class	H (180°C) (356°F)						

D

Inch equivalents for millimeter dimensions are shown in (**)

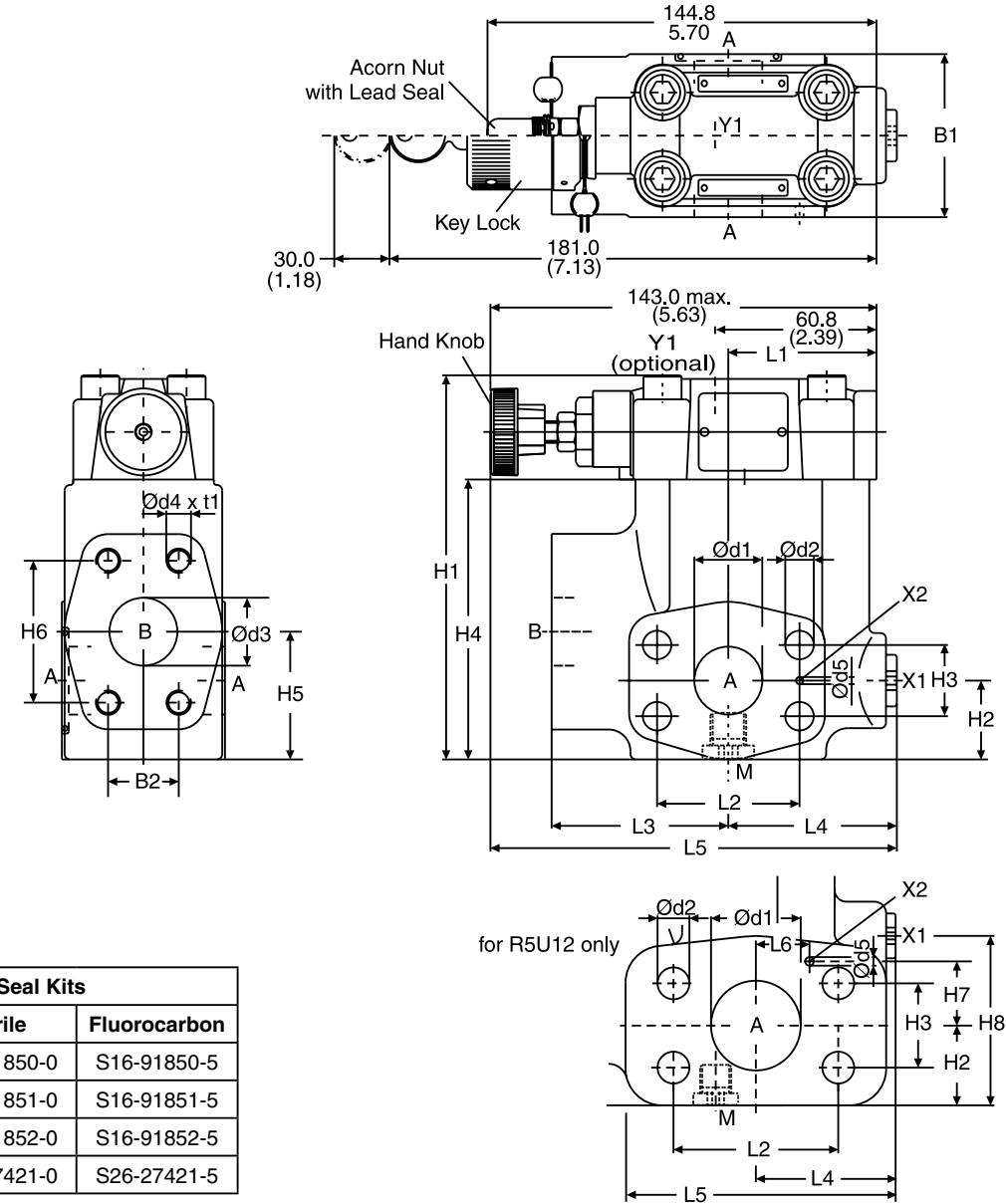

Seal Kits		
Size	Nitrile	Fluorocarbon
06	S16-91850-0	S16-91850-5
08	S16-91851-0	S16-91851-5
10	S16-91852-0	S16-91852-5
12	S26-27421-0	S26-27421-5

Size	B1	B2	H1	H2	H3	H4	H5	H6	L1	L2	L3	L4	L5	d1	d2	d3	d4	t1	d5	L6	H7	H8
06	60.0 (2.36)	22.2 (0.87)	119.0 (4.69)	28.0 (1.10)	22.2 (0.87)	81.0 (3.19)	41.6 (1.64)	47.6 (1.87)	50.0 (1.98)	47.6 (1.87)	63.0 (2.48)	56.0 (2.20)	152.0 (5.98)	19.0 (0.75)	10.5 (0.41)	19.0 (0.75)	3/8"-16 UNC	20.0 (0.79)	3.0 (0.12)	-	-	-
08	60.0 (2.36)	26.2 (1.03)	141.0 (5.55)	29.0 (1.14)	26.2 (1.03)	103.0 (4.06)	47.0 (1.85)	52.4 (2.06)	55.8 (2.20)	52.4 (2.06)	65.0 (2.56)	58.0 (2.28)	149.0 (5.87)	25.0 (0.98)	10.5 (0.41)	25.0 (0.98)	3/8"-16 UNC	23.0 (0.91)	3.0 (0.12)	-	-	-
10	75.0 (2.95)	30.2 (1.19)	151.0 (5.94)	34.5 (1.36)	30.2 (1.19)	113.0 (4.45)	64.0 (2.52)	58.7 (2.31)	57.8 (2.28)	58.7 (2.31)	61.0 (2.40)	62.0 (2.44)	150.5 (5.93)	32.0 (1.26)	12.5 (0.49)	32.0 (1.26)	7/16"-14 UNC	22.0 (0.87)	3.0 (0.12)	-	-	-
12	80.0 (3.15)	35.7 (1.41)	178.0 (7.01)	34.0 (1.34)	35.7 (1.41)	140.0 (5.51)	73.0 (2.87)	69.8 (2.75)	37.3 (1.47)	69.8 (2.75)	92.5 (3.64)	55.2 (2.17)	171.2 (6.74)	38.0 (1.50)	13.5 (0.53)	38.0 (1.50)	1/2"-13 UNC	27.0 (1.06)	3.0 (0.12)	22.4 (0.88)	27.2 (1.07)	73.0 (2.87)

Port	Function	Port Size			
		R5U06	R5U08	R5U10	R5U12
A (2)	Pressure	3/4" SAE 61	1" SAE 61	1-1/4" SAE 61	1-1/2" SAE 61
B	Tank	3/4" SAE 61	1" SAE 61	1-1/4" SAE 61	1-1/2" SAE 61
X1	External Pilot Port*	SAE 4			
Y1	External Drain	SAE 4			
M	Pressure Gauge	SAE 4			

* closed when supplied.

R5U.indd, dd

Inch equivalents for millimeter dimensions are shown in (**)

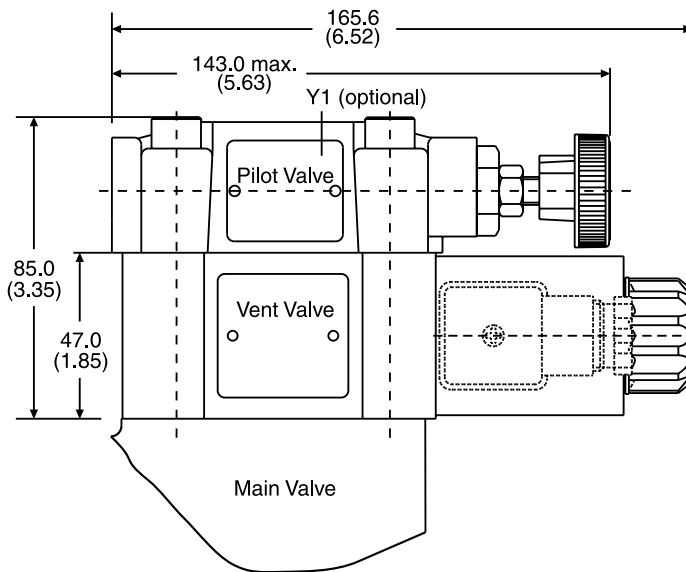
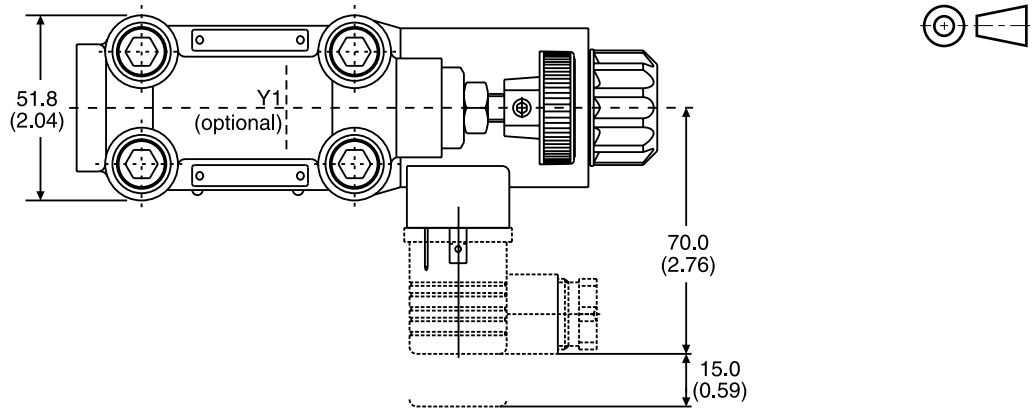

D

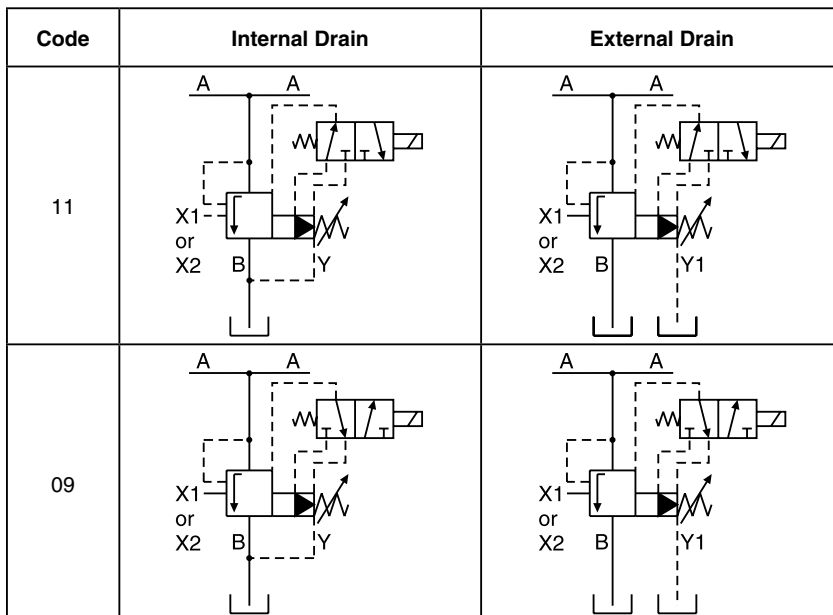

Vent Valve Seal Kits	
Nitrile	Fluorocarbon
DC Solenoid	
S26-58515-0	S26-58515-5
AC Solenoid	
S26-35237-0	S26-35237-5