

# PRE\*G

## PILOT OPERATED PRESSURE RELIEF VALVES WITH PROPORTIONAL CONTROL AND INTEGRAL ELECTRONICS

### SERIES 31

**SUBPLATE MOUNTING  
ISO 6264**

**p** max **350** bar  
**Q** max (see table of performances)

#### OPERATING PRINCIPLE

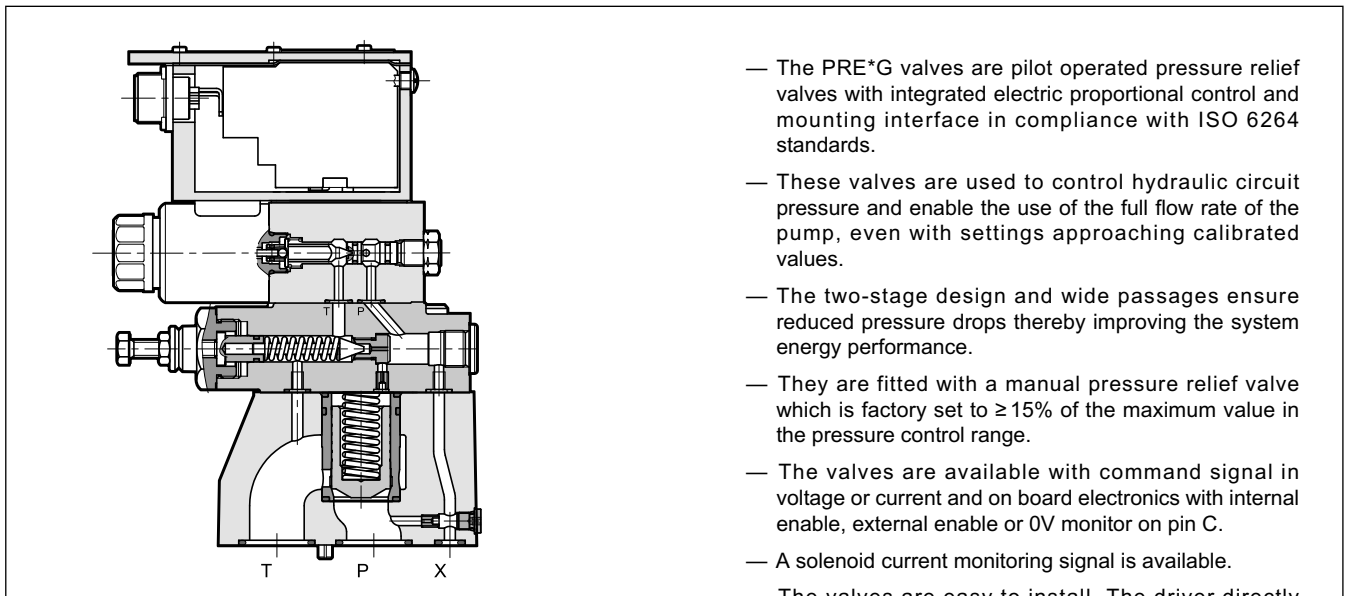

- The PRE\*G valves are pilot operated pressure relief valves with integrated electric proportional control and mounting interface in compliance with ISO 6264 standards.
- These valves are used to control hydraulic circuit pressure and enable the use of the full flow rate of the pump, even with settings approaching calibrated values.
- The two-stage design and wide passages ensure reduced pressure drops thereby improving the system energy performance.
- They are fitted with a manual pressure relief valve which is factory set to  $\geq 15\%$  of the maximum value in the pressure control range.
- The valves are available with command signal in voltage or current and on board electronics with internal enable, external enable or 0V monitor on pin C.
- A solenoid current monitoring signal is available.
- The valves are easy to install. The driver directly manages digital settings.

#### PERFORMANCES

(obtained with mineral oil with viscosity of 36 cSt at 50°C and p = 140 bar)

		PRE10G	PRE25G	PRE32G
Maximum operating pressure	bar	350		
Maximum flow	l/min	200	400	500
Step response		see paragraph 6		
Hysteresis	% of p nom	< 3%		
Repeatability	% of p nom	< $\pm 1\%$		
Electrical characteristic		see paragraph 2		
Ambient temperature range	°C	-20 / +60		
Fluid temperature range	°C	-20 / +80		
Fluid viscosity range	cSt	10 ÷ 400		
Fluid contamination degree		According to ISO 4406:1999 class 18/16/13		
Recommended viscosity	cSt	25		
Mass	kg	5,5	6,3	8,5

— They are available in three sizes with flow rates up to 500 l/min and in four pressure control ranges up to 350 bar.

#### HYDRAULIC SYMBOL

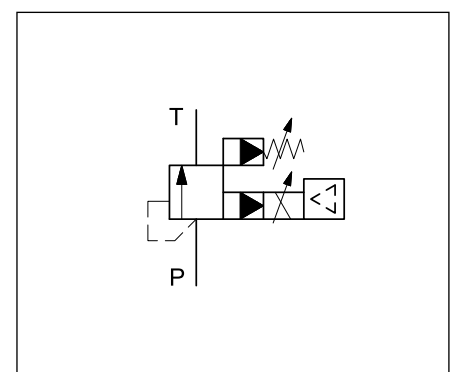



## 1 - IDENTIFICATION CODE

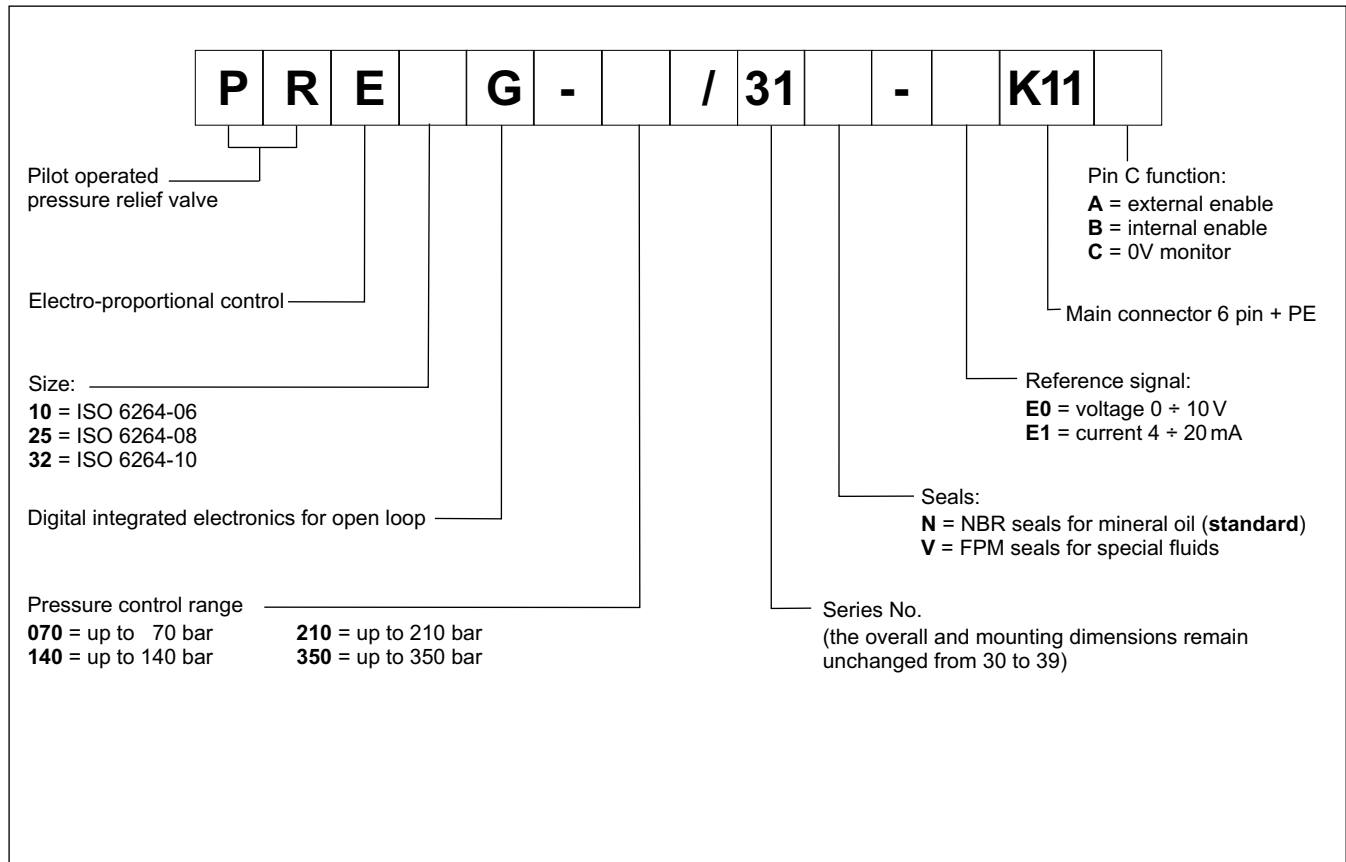

## 2 - ELECTRICAL CHARACTERISTICS

### 2.1 - Electrical on board electronics

Duty cycle		100% (continuous operation)
Protection class according to IEC 60529		IP65 / IP67
Supply voltage	V DC	24 (from 19 to 30 VDC), ripple max 3 Vpp
Power consumption	VA	25
Maximum solenoid current	A	1.88
Fuse protection, external		2A time lag
Command signals: voltage (E0) current (E1)	V DC mA	0 ÷ 10 (Impedance Ri > 11 kOhm) 4 ÷ 20 (Impedance Ri = 58 Ohm)
Monitor signal (current to solenoid): voltage (E0) current (E1)	V DC mA	0 ÷ 10 (Impedance Ro > 1 kOhm) 4 ÷ 20 (Impedance Ro = 500 Ohm)
Managed breakdowns		Overload and electronics overheating, cable breakdown, supply voltage failures
Communication		LIN-bus Interface (with the optional kit)
Connection		7 - pin MIL-C-5015-G (DIN-EN 175201-804)
Electromagnetic compatibility (EMC) emissions EN 61000-6-4 immunity EN 61000-6-2		According to 2014/30/EU standards

### 2.2 - On-board electronics diagrams

**VERSION A - External Enable**

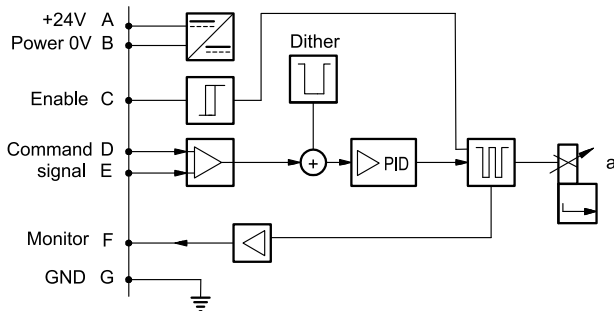

**VERSION B - Internal Enable**

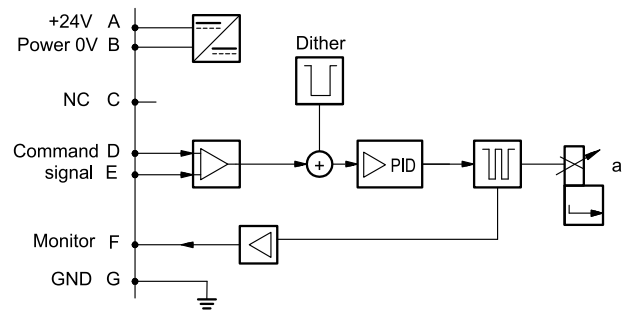

**VERSION C - 0V Monitor**

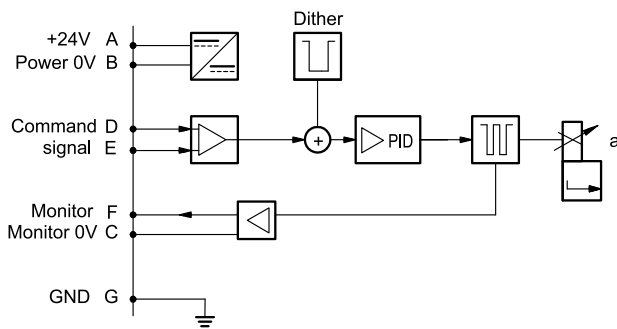

### 3 - VERSIONS WITH VOLTAGE COMMAND (E0)

The reference signal is between 0 ÷ 10V. The monitor feature of versions B and C becomes available with a delay of 0,5 sec from the power-on of the card.

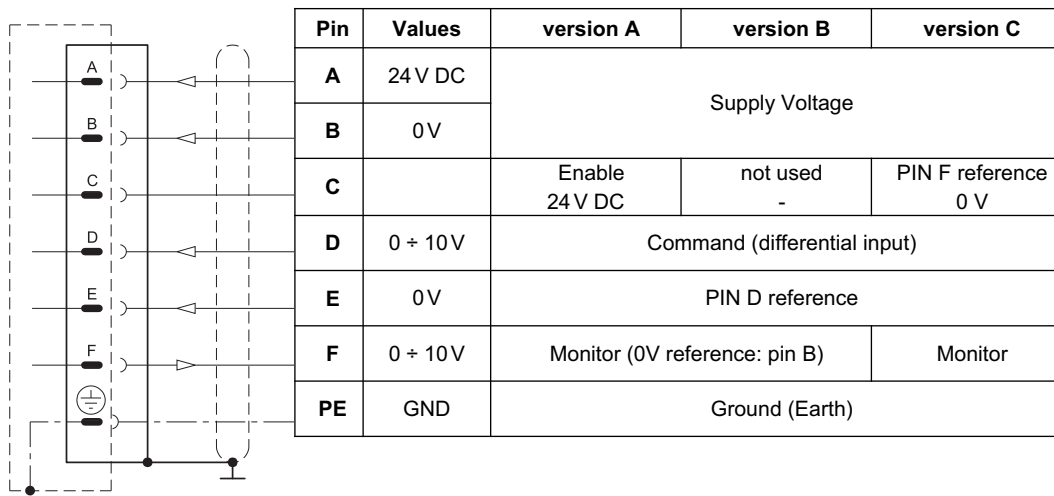
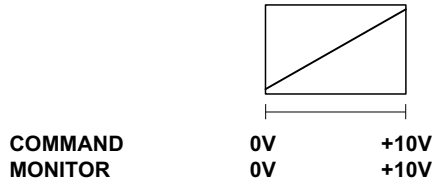

### 4 - VERSIONS WITH CURRENT COMMAND (E1)

The reference signal is supplied in current 4 ÷ 20 mA. If the current for command is lower, the card shows a breakdown cable error. To reset the error is sufficient to restore the signal.

The monitor feature of versions B and C becomes available with a delay of 0,5 sec from the power-on of the card.

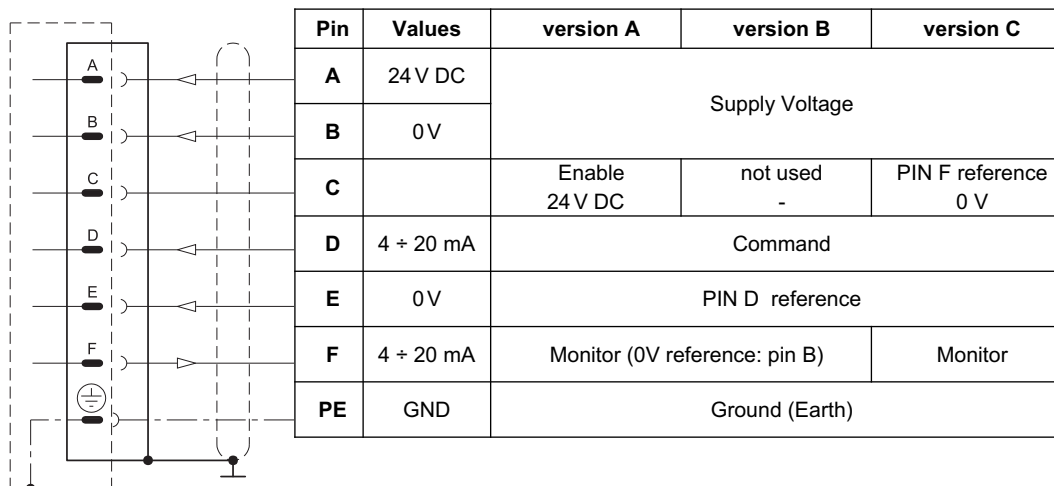
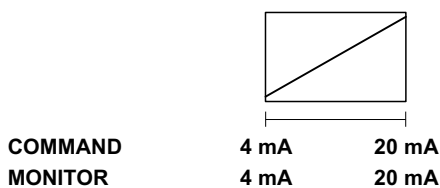



**5 - CHARACTERISTIC CURVES**

(obtained with mineral oil with viscosity of 36 cSt at 50°C)

**PRESSURE CONTROL  $p = f(I)$**

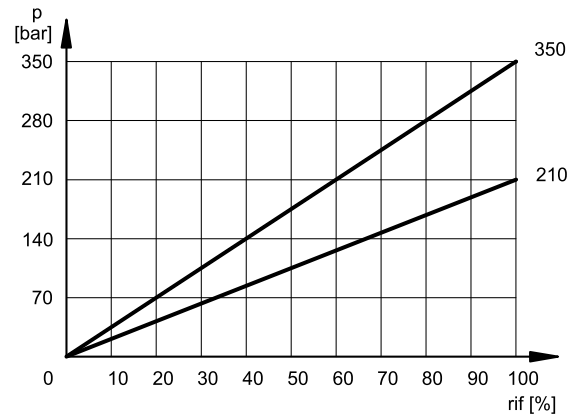
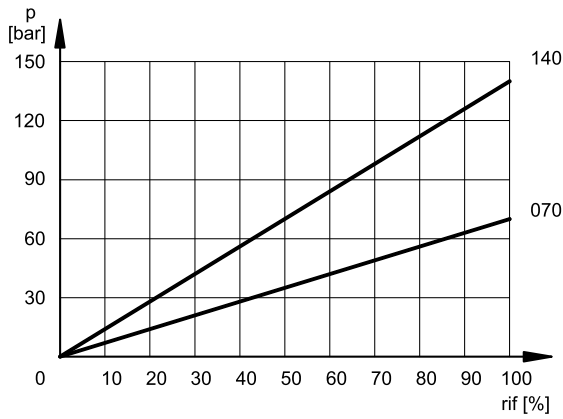

**PRESSURE CONTROL  $p = f(Q)$**

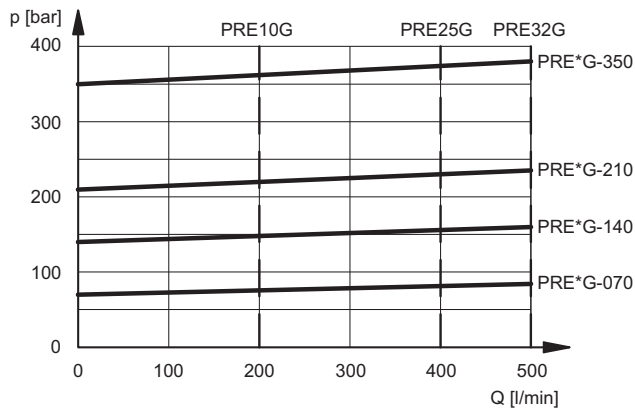

**PRESSURE DROPS  $\Delta p = f(Q)$**

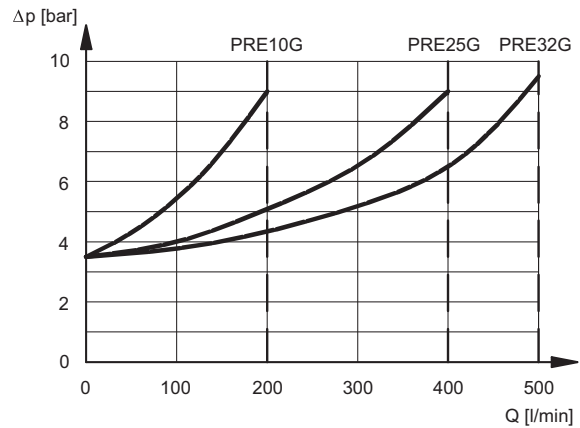

**6 - STEP RESPONSE**

(obtained with mineral oil with viscosity of 36 cSt at 50°C)

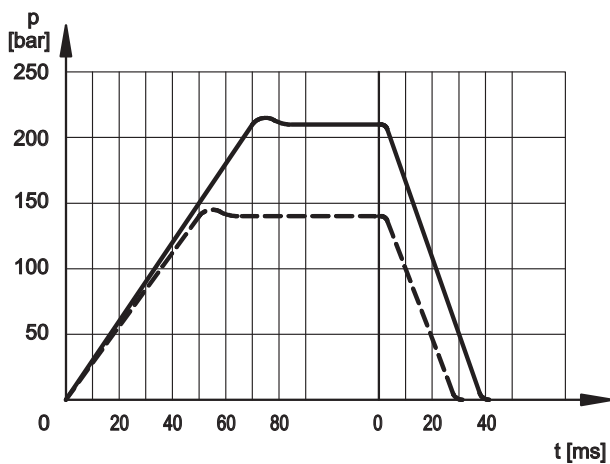

—— full-scale 210 bar  
- - - - full-scale 140 bar

**NOTE:** Response times are obtained with PRE25G valves.

## 7 - OVERALL AND MOUNTING DIMENSIONS PRE10G

dimensions in mm

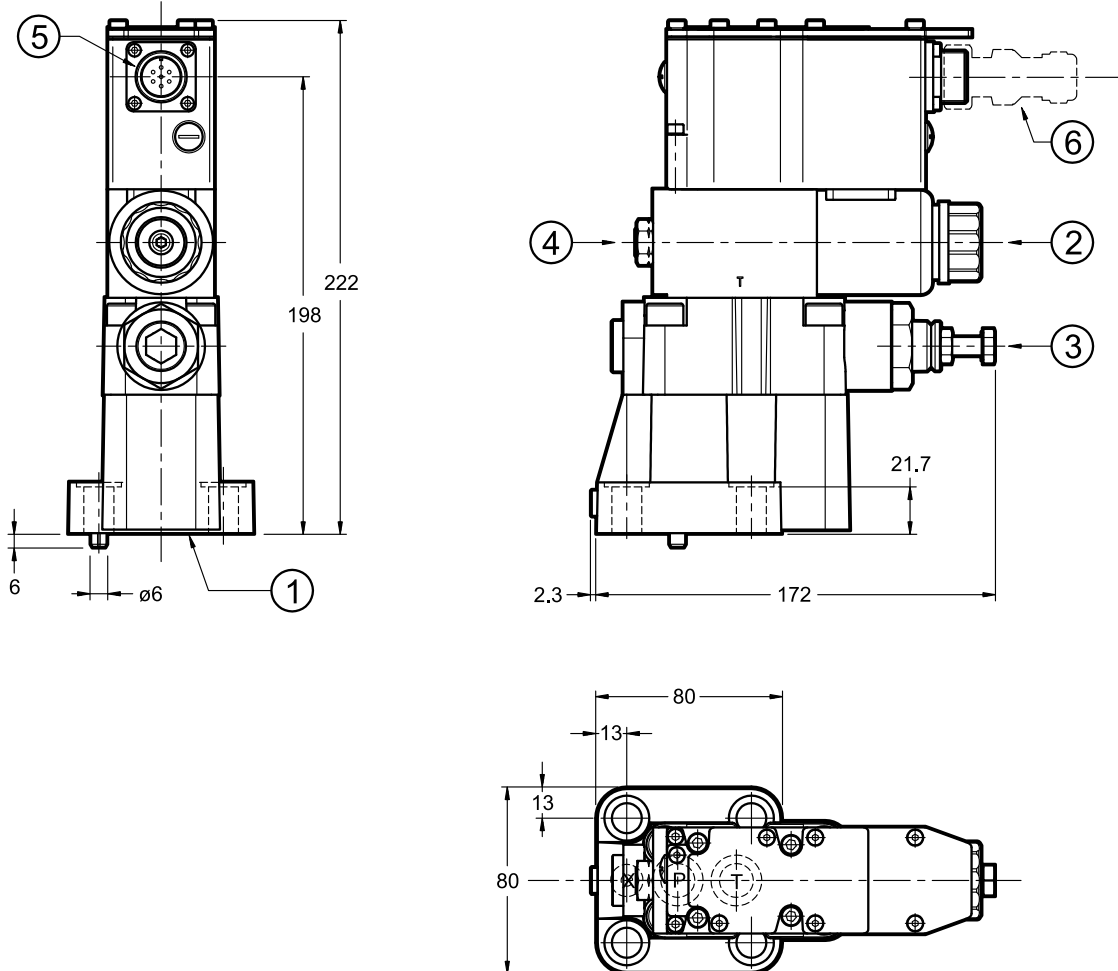

**NOTE:**

at the first start up, or after a long period of no use, it is necessary to vent the air through the breather (2) placed at the end of the solenoid tube.

Fastening bolts: 4 SHCS M12x40 - ISO 4762  
 Torque: 69 Nm (viti A8.8)  
 Thread of mounting holes: M12x20

**MOUNTING INTERFACE:**

ISO 6264-06-09-\*97  
 (CETOP 4.4.2-2-R06-350)

1	Mounting surface with sealing rings: 2 OR type 123 (17.86x2.62) - 90 Shore 1 OR type 109 (9.13x2.62) - 90 Shore
2	Breather: Allen key 4
3	Factory-set pressure relief valve
4	Factory sealing setting (we recommend not unscrewing the nut)
5	Main connection
6	Mating electrical connector <b>to be ordered separately.</b> See at section 12

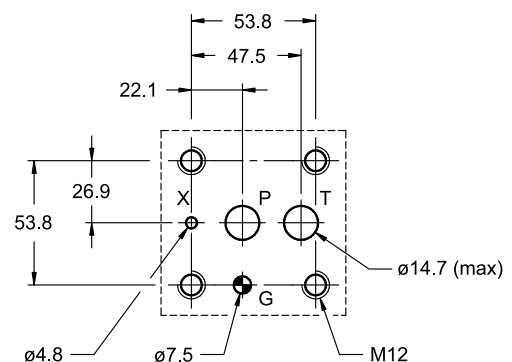

## 8 - OVERALL AND MOUNTING DIMENSIONS PRE25G

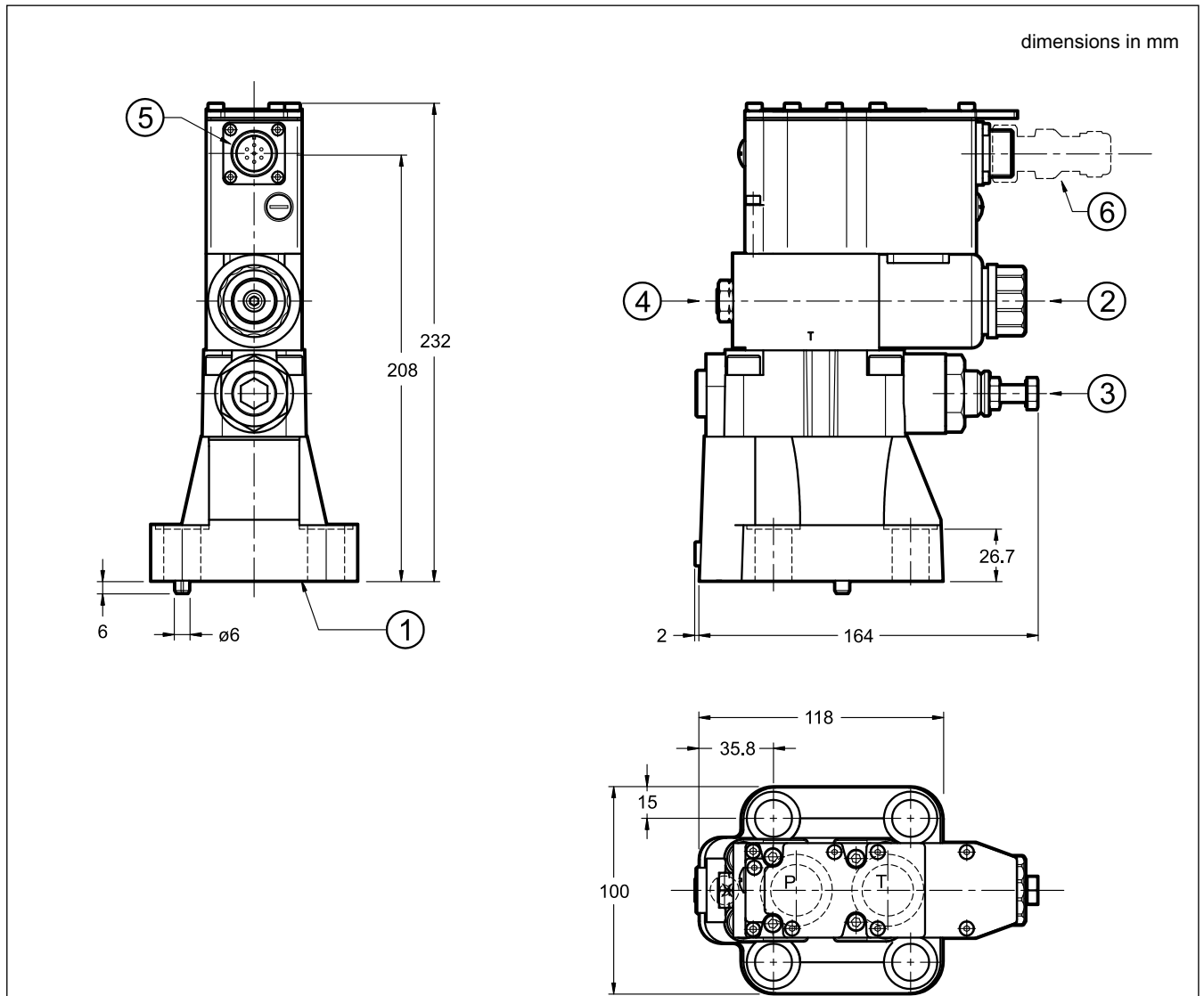

**NOTE:**

at the first start up, or after a long period of no use, it is necessary to vent the air through the breather (2) placed at the end of the solenoid tube.

Fastening bolts: 4 SHCS M16x60 - ISO 4762  
 Torque: 170 Nm (viti A8.8)  
 Thread of mounting holes: M16x25

**MOUNTING INTERFACE:**

ISO 6264-08-13-\*97  
 (CETOP 4.4.2-2-R08-350)

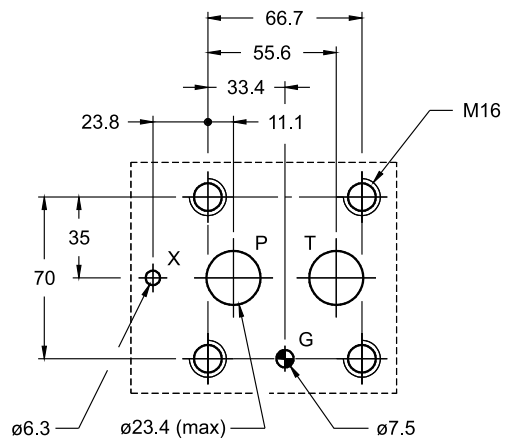

1	Mounting surface with sealing rings: 2 OR type 3118 (29.82x2.62) - 90 Shore 1 OR type 109 (9.13x2.62) - 90 Shore
2	Breather: Allen key 4
3	Factory-set pressure relief valve
4	Factory sealing setting (we recommend not unscrewing the nut)
5	Main connection
6	Mating electrical connector <b>to be ordered separately.</b> See at section 12

## 9 - OVERALL AND MOUNTING DIMENSIONS PRE32G

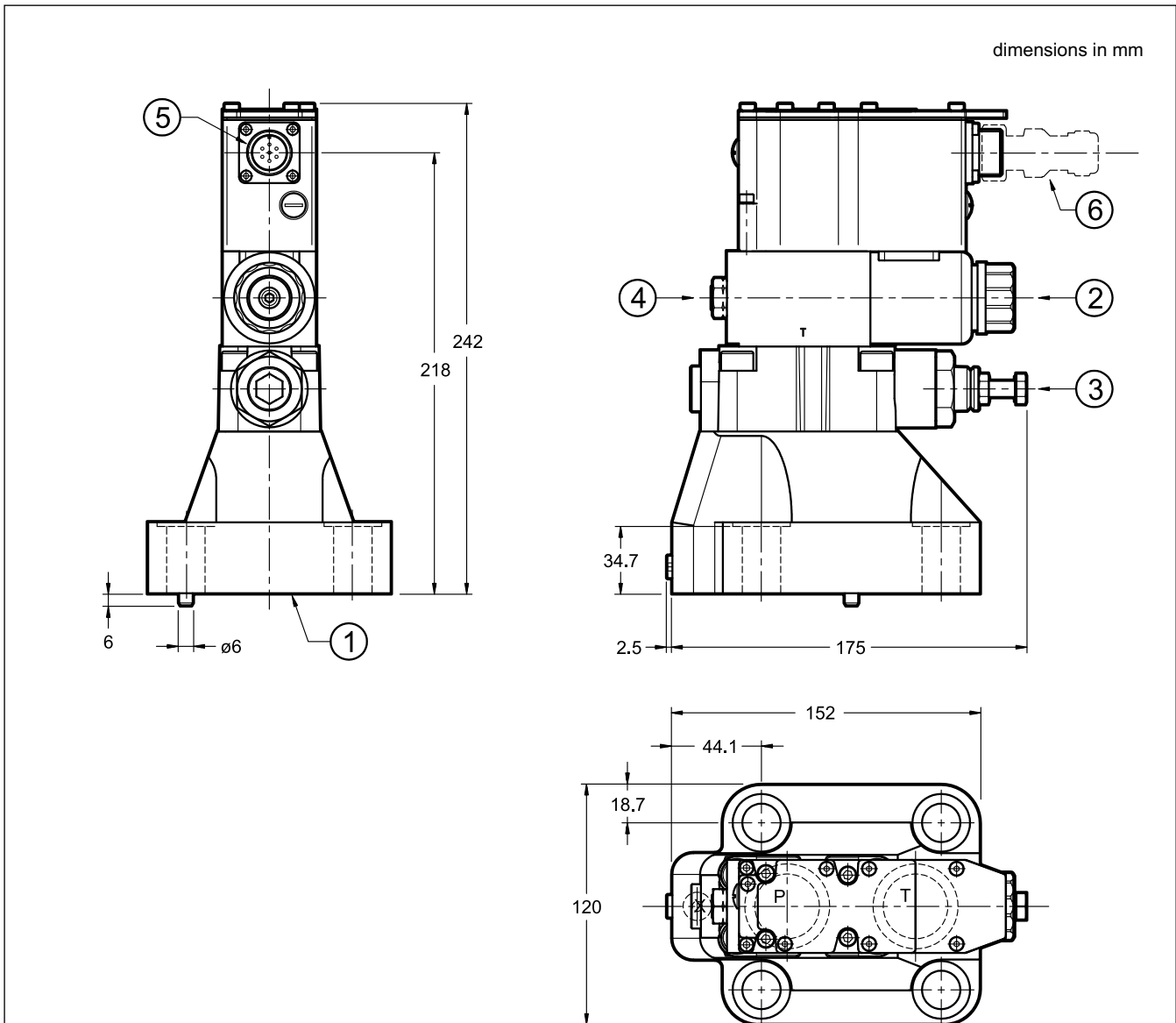

**NOTE:**

at the first start up, or after a long period of no use, it is necessary to vent the air through the breather (2) placed at the end of the solenoid tube.

Fastening bolts: 4 SHCS M18x60 - ISO 4762  
 Torque: 235Nm (viti A8.8)  
 Thread of mounting holes: M18x27

**MOUNTING INTERFACE**

ISO 6264-10-17-\*97  
 (CETOP 4.4.2-2-R10-350)

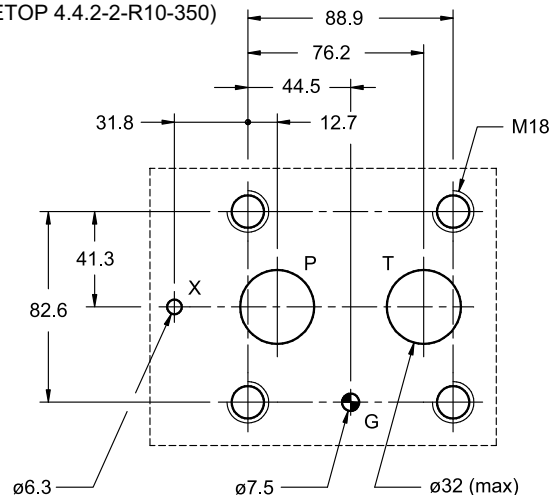

1	Mounting surface with sealing rings: 2 OR type 4137 (34.52x3.53) - 90 Shore 1 OR type 109 (9.13x2.62) - 90 Shore
2	Breather: Allen key 4
3	Factory-set pressure relief valve
4	Factory sealing setting (we recommend not unscrewing the nut)
5	Main connection
6	Mating electrical connector <b>to be ordered separately.</b> See at section 12



## 10 - HYDRAULIC FLUIDS

Use mineral oil-based hydraulic fluids HL or HM type, according to ISO 6743-4. For these fluids, use NBR seals. For fluids HFDR type (phosphate esters) use FPM seals (code V). For the use of other kinds of fluid such as HFA, HFB, HFC, please consult our technical department.

Using fluids at temperatures higher than 80 °C causes a faster degradation of the fluid and of the seals characteristics.

The fluid must be preserved in its physical and chemical characteristics.

## 11 - INSTALLATION

We recommend to install the valves either in horizontal position, or vertical position with the solenoid downward. If the valve is installed in vertical position and with the solenoid upward, you must consider possible variations of the minimum controlled pressure, if compared to what is indicated in paragraph 5.

Ensure that there is no air in the hydraulic circuit. In particular applications, can be necessary to vent the air entrapped in the solenoid tube, by using the appropriate drain screw in the solenoid tube.

Ensure the solenoid tube is always filled with oil. At the end of the operation, make sure of having correctly replaced the drain screw.

**Connect the valve T port directly to the tank. Add any backpressure value detected in the T line to the controlled pressure value.**

**Maximum admissible backpressure in the T line, under operational conditions, is 2 bar.**

Valves are fixed by means of screws or tie rods on a flat surface with planarity and roughness equal to or better than those indicated in the relative symbols. If minimum values are not observed, fluid can easily leak between the valve and support surface.

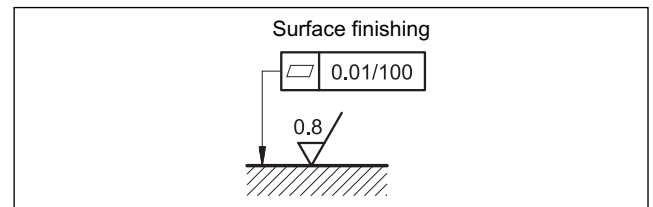

## 12 - ACCESSORIES

(to be ordered separately)

### 12.1 - Mating connector

These valves have a plug for 7-pin mating connector, that is placed on the box of the integral motion control.



So as to avoid electromagnetic troubles and comply with the electromagnetic compatibility regulation EMC, it is recommended the use of a metal connector.

If a plastic connector is used, make sure that the protection characteristics IP and EMC of the valve are guaranteed.

Duplomatic offers a metal cable connector type MIL-C-5015-G (EN 175201-804).

name: **EX7S/L/10** code **3890000003**

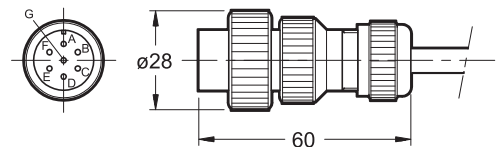

### 12.2 - Connection cables size

Power supply:

- up to 20 m cable length : 1,0 mm<sup>2</sup>
- up to 40 m cable length : 1,5 mm<sup>2</sup>

Signal: 0,50 mm<sup>2</sup>

A suitable cable would have 7 isolated conductors, a separate screen for the signal wires and an overall screen.

### 12.3 - Kit for start-up LINPC-USB

Device for service start-up and diagnostic, see catalogue 89850.



### 13 - SUBPLATES

(see catalogue 51 000)

	PRE10G	PRE25G	PRE32G
Type	PMRQ3-AI4G rear ports	PMRQ5-AI5G rear ports	PMRQ7-AI7G rear ports
P, T port dimensions	1/2" BSP	1" BSP	1" 1/4 BSP
X port dimensions	1/4" BSP	1/4" BSP	1/4" BSP



**DIPLOMATiC OLEODiNAMiCA S.p.A.**  
20015 PARABIAGO (MI) • Via M. Re Depaolini 24  
Tel. +39 0331.895.111  
Fax +39 0331.895.339  
www.diplomatic.com • e-mail: sales.exp@diplomatic.com

