

General Description

Series PRDM are direct operated pressure reducing valves that are used to regulate pressure in one area of a hydraulic circuit at a predetermined level below normal system pressure. Additionally, an integral pressure relieving function for the secondary reduced pressure circuit is incorporated into the design.

B

Operation

These valves are “normally open” devices that allow fluid to flow through the controlled port during their non-actuated or “at rest” condition. When downstream pressure exceeds the value set by the spring force, the control piston moves off its seat, closing off the flow path and thus reducing the fluid passing through from the main system. The cushioned piston modulates to maintain the preset pressure in this branch of the hydraulic circuit. If, due to external forces, the pressure continues to rise in this branch circuit, the piston will keep moving against the spring force allowing fluid to be drained to tank, thereby limiting maximum pressure to the valve’s setting.

Features

- PRDM Manapak sandwich valves may be selected to reduce pressure in the 'P' port, 'A' port or 'B' port.
- The direct operated, cushioned piston design results in fast response, low leakage and minimal hysteresis.
- Up to nine pressure adjustment ranges are available with maximum pressure settings.
- Adjustment options include: internal hex screw, hand knob or internal hex with keylock.
- Fluorocarbon seals are available.
- Available gage port connections include SAE and NPT.

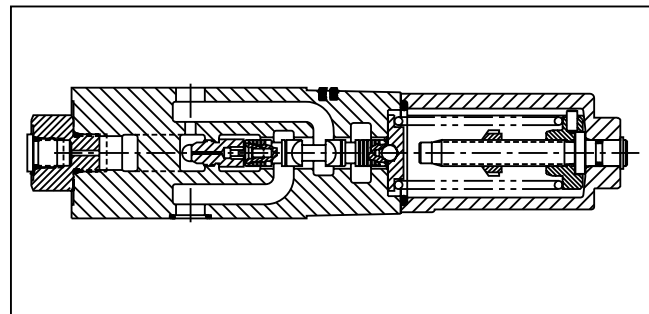
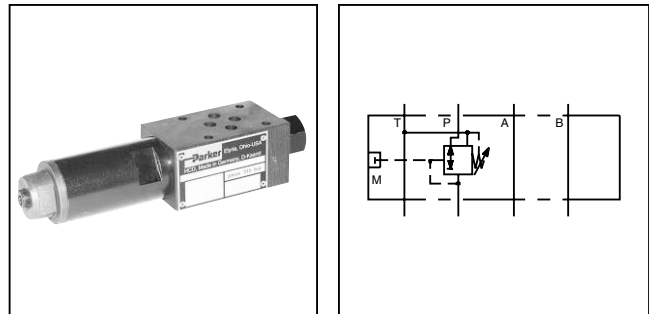

Specifications

	PRDM2	PRDM3
Mounting Pattern	NFPA D03, CETOP 3, NG6	NFPA D05, CETOP 5, NG10
Maximum Operating Pressure P, A, B	350 Bar (5000 PSI)	315 Bar (4560 PSI)
T	10 Bar (145 PSI)	10 Bar (145 PSI)
Max. Flow	40 LPM (10.5 GPM)	80 LPM (21 GPM)
Pressure Range	Code Range 01 1.0 to 14 Bar (15 to 200 PSI) 02* 1.5 to 25 Bar (22 to 363 PSI) 05** 2 to 50 Bar (29 to 725 PSI) 06* 1.5 to 64 Bar (22 to 928 PSI) 10** 4 to 100 Bar (58 to 1450 PSI) 15** 6 to 150 Bar (87 to 2175 PSI) 16* 3 to 160 Bar (44 to 2320 PSI) 21 3 to 210 Bar (44 to 3045 PSI) 35* 10 to 315 Bar (147 to 4560 PSI)	
Viscosity Range	12-230 cSt (62-1190 SSU)	
Filtration	ISO Code 18/16/13 or Better	

* PRDM2 only

** PRDM3 only.

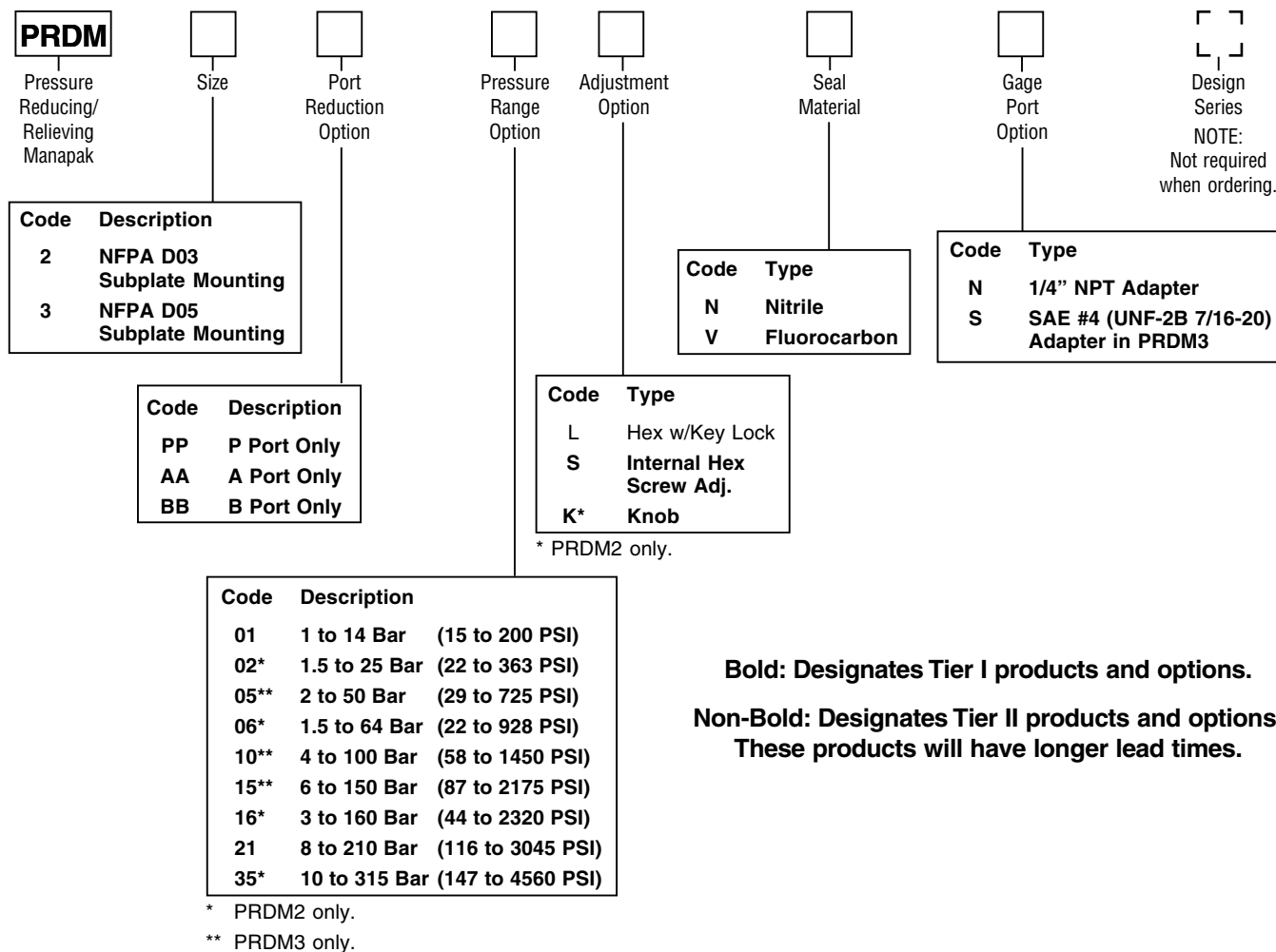

Bold: Designates Tier I products and options.
Non-Bold: Designates Tier II products and options.
 These products will have longer lead times.

Manapak Bolt Kits

Size "2"				Size "3"			
No. of Manapaks	Manapak & Valve Combination	Bolt Kit	Bolt Length mm (in)	No. of Manapaks	Manapak & Valve Combination	D3W-30 D3DW & D31VW*	Bolt Length mm (in)
1	Manapak & D1	BK243	73.2 (2.88)	1	Manapak & D3	BK141	88.9 (3.50)
2	Manapak & D1	BK225	111.3 (4.38)	2	Manapak & D3	BK142	139.7 (5.50)
3	Manapak & D1	BK244	152.4 (6.00)	3	Manapak & D3	BK143	190.5 (7.50)
4	Manapak & D1	BK245	190.5 (7.50)				

* D31VW with internal pilot and internal drain only.

Bolt Kits must be ordered separately.

Weights:

PRDM2 1.3 kg (2.9 lbs.)
 PRDM3 2.6 kg (5.8 lbs.)

Schematics

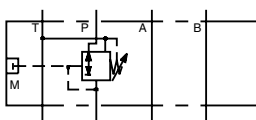

PP Option

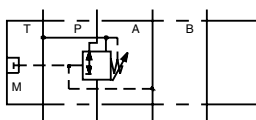

AA Option

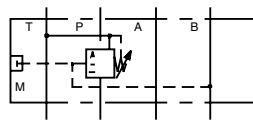

BB Option

B

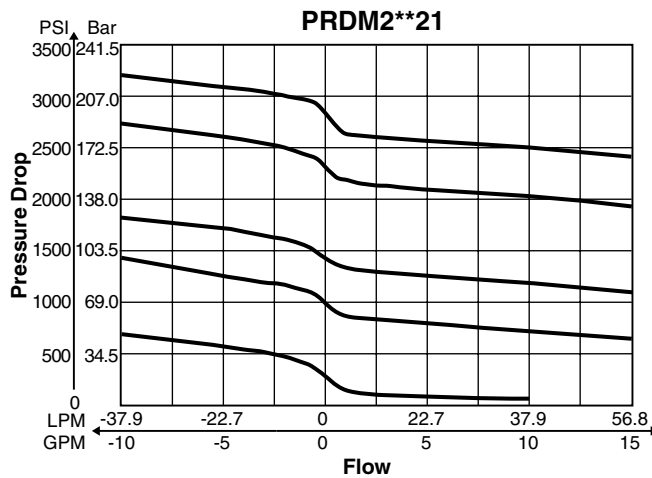
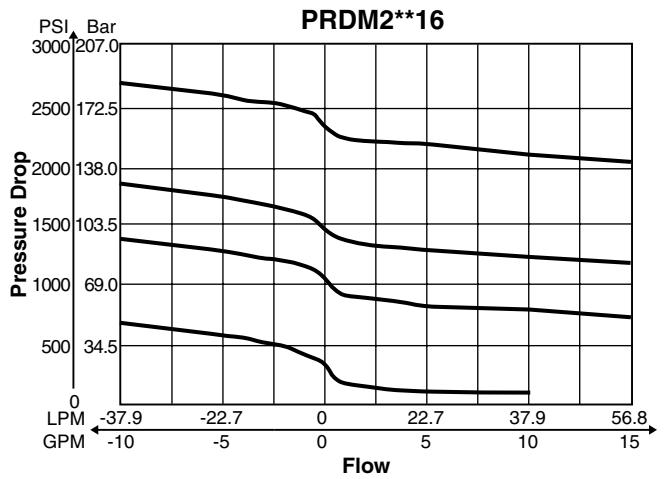
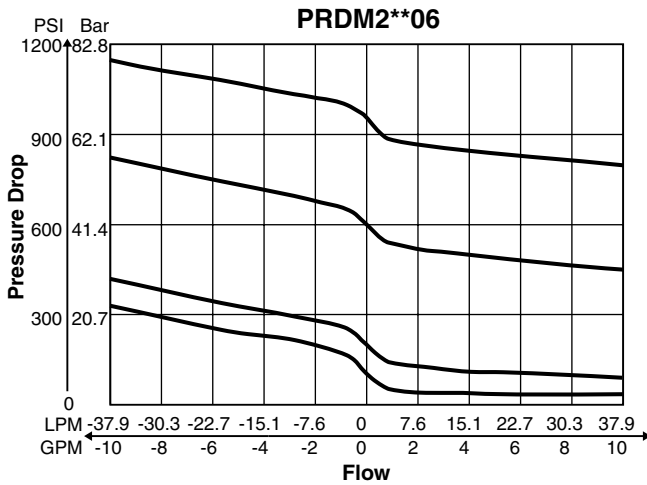
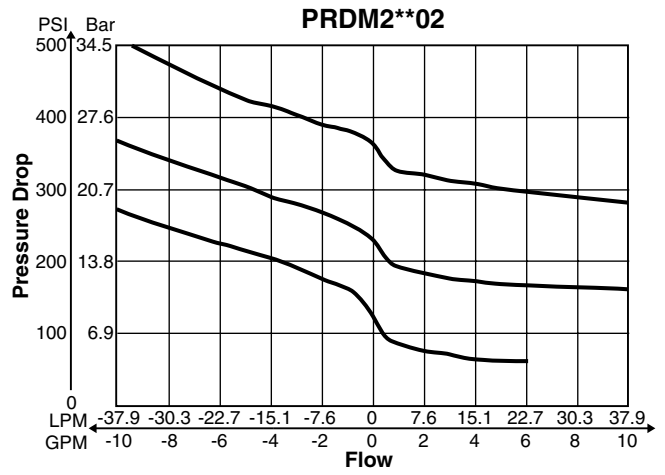
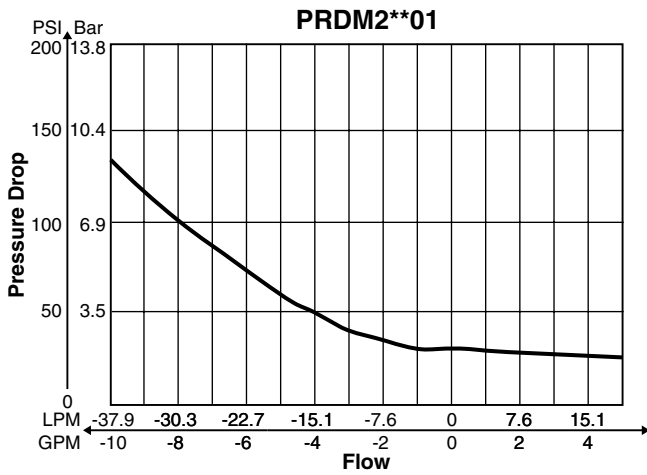

NOTE: Lowest pressure setting dependent upon system resistance.

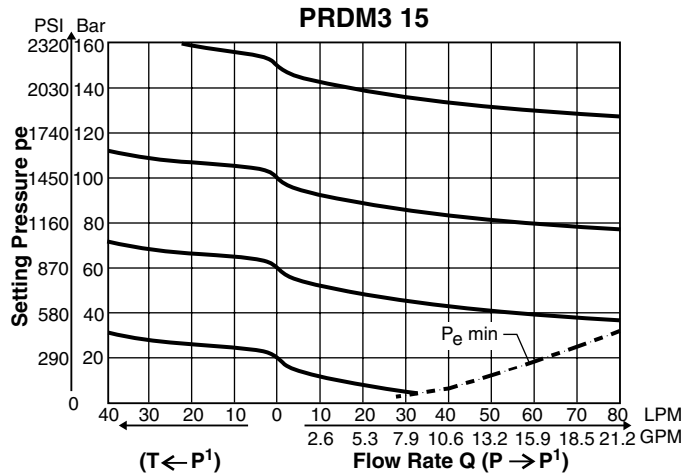
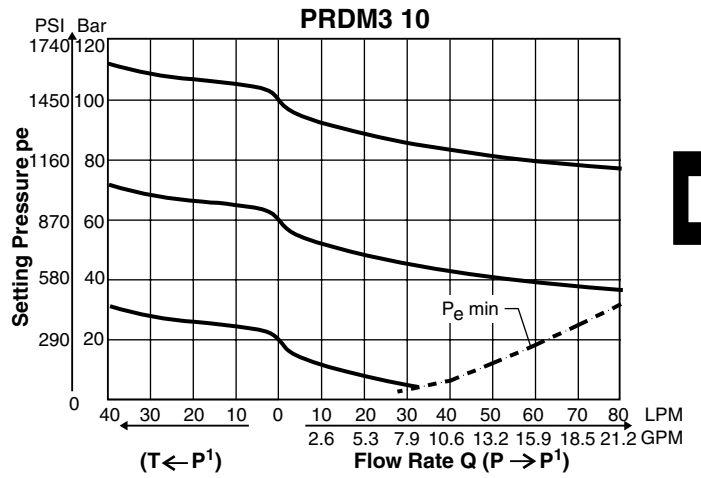
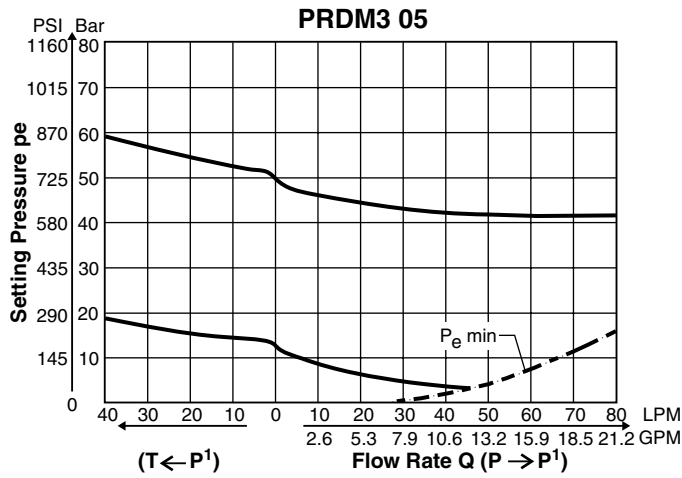

NOTE: Lowest pressure setting dependent upon system resistance.

PRDM2

Inch equivalents for millimeter dimensions are shown in (**)

B

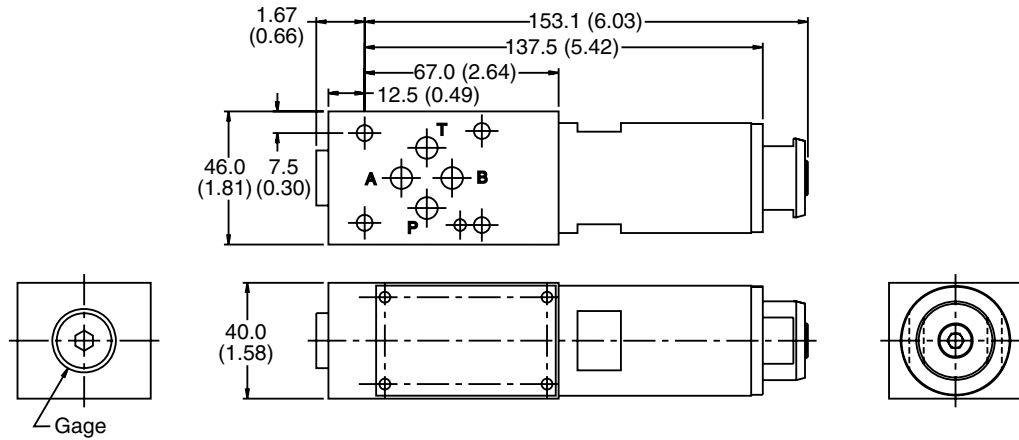
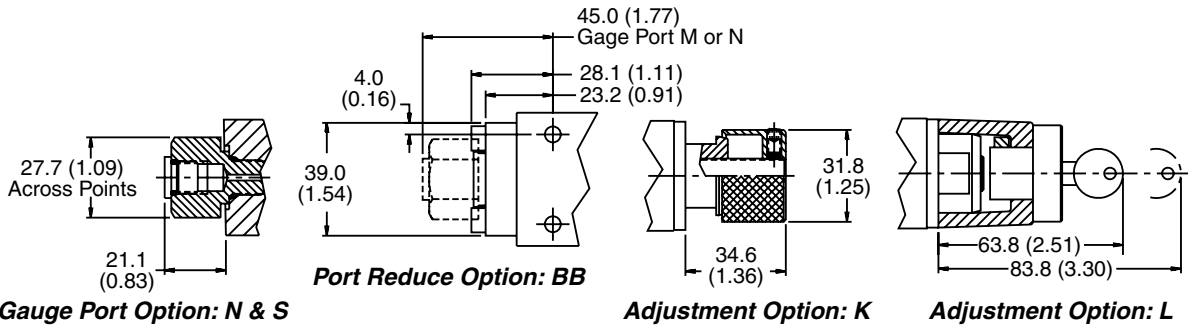

PRDM3

Inch equivalents for millimeter dimensions are shown in (**)

