

# Motor controller

## CMMP-AS-...-M0

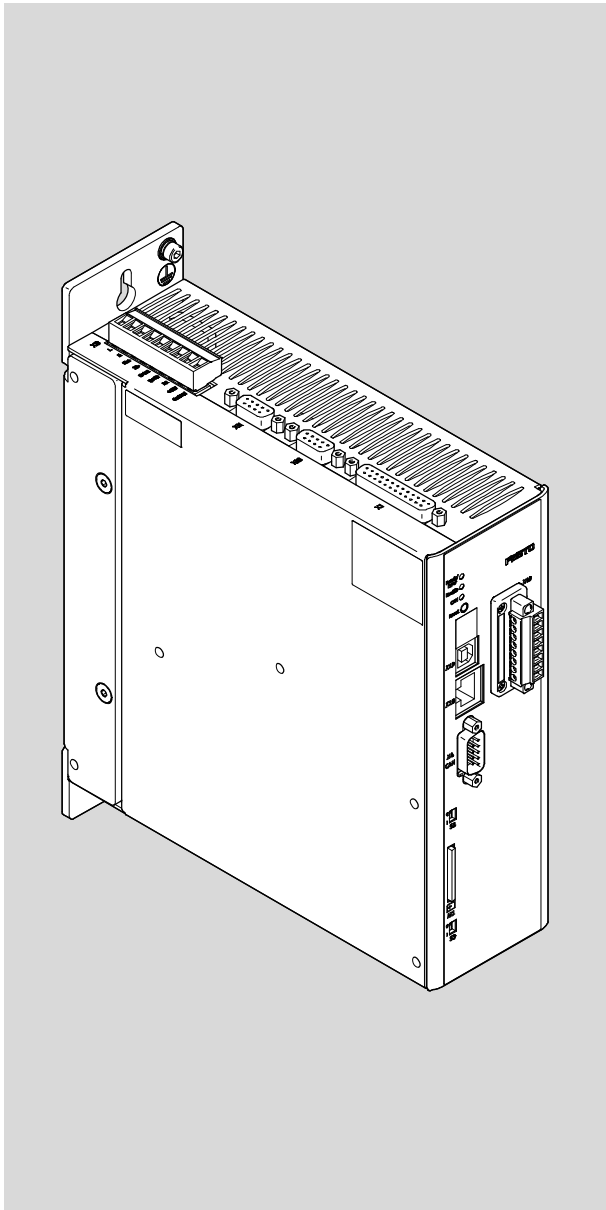

# FESTO

### Description

Mounting and installation

For motor controller CMMP-AS-...-M0

Translation of the original instructions  
GDCP-CMMP-M0-HW-EN

CANopen®, Heidenhain®, EnDat®, PHOENIX®, Windows® are registered trademarks of the respective trademark owners in certain countries.

Identification of hazards and instructions on how to prevent them:



**Danger**

Immediate dangers which can lead to death or serious injuries



**Warning**

Hazards that can cause death or serious injuries



**Caution**

Hazards that can cause minor injuries or serious material damage

Other symbols:



**Note**

Material damage or loss of function



Recommendations, tips, references to other documentation



Essential or useful accessories



Information on environmentally sound usage

Text designations:

- Activities that may be carried out in any order
- 1. Activities that should be carried out in the order stated
  - General lists
- ➔ Result of an action/References to more detailed information

## Table of Contents – CMMP-AS-...-M0

Instructions on this documentation .....	6
Target group .....	6
Product identification, versions .....	6
Service .....	6
Specified standards/directives .....	6
Documentation .....	8
<b>1 Safety and requirements for product use .....</b>	<b>9</b>
1.1 Safety .....	9
1.1.1 Safety instructions for commissioning, repair and de-commissioning .....	9
1.1.2 Protection against electric shock through protective extra-low voltage (PELV) ..	10
1.1.3 Intended use .....	10
1.2 Requirements for product use .....	11
1.2.1 Transport and storage conditions .....	11
1.2.2 Technical requirements .....	11
1.2.3 Qualification of the specialists (requirements for the personnel) .....	11
1.2.4 Range of application and certifications .....	11
<b>2 Product overview .....</b>	<b>13</b>
2.1 The entire system for the CMMP-AS-...-M0 .....	13
2.2 Scope of delivery .....	14
2.3 Device view .....	15
<b>3 Mechanical installation .....</b>	<b>19</b>
3.1 Important notes .....	19
3.2 Mounting .....	20
3.2.1 Motor controller .....	20
<b>4 Electrical installation .....</b>	<b>23</b>
4.1 Safety instructions .....	23
4.2 Allocation of the plug connectors .....	25
4.3 Connection: I/O communication [X1] .....	29
4.3.1 Plug [X1]: .....	29
4.3.2 Pin assignment [X1] .....	29
4.3.3 Use analogue inputs as digital inputs .....	30
4.4 Connection: Resolver [X2A] .....	32
4.4.1 Plug [X2A] .....	32
4.4.2 Pin assignment [X2A] .....	32
4.5 Connection: Encoder [X2B] .....	33
4.5.1 Plug [X2B] .....	33

4.5.2	Pin assignment [X2B] .....	33
4.6	Connection: CAN bus [X4] .....	36
4.6.1	Plug [X4] .....	36
4.6.2	Pin assignment [X4] .....	36
4.7	Connection: Motor [X6] .....	37
4.7.1	Plug [X6] .....	37
4.7.2	Pin assignment [X6] .....	37
4.8	Connection: Voltage supply [X9] .....	39
4.8.1	Plug .....	39
4.8.2	Pin assignment [X9] – single-phase .....	39
4.8.3	Pin assignment [X9] – triple-phase .....	40
4.8.4	Mains fuse .....	41
4.8.5	AC supply .....	41
4.8.6	Braking resistor .....	43
4.9	Connection: Incremental encoder input [X10] .....	44
4.9.1	Plug [X10] .....	44
4.9.2	Pin assignment [X10] .....	44
4.9.3	Type and design of the cable [X10] .....	45
4.9.4	Connection instructions [X10] .....	45
4.10	Connection: Incremental encoder output [X11] .....	45
4.10.1	Plug [X11] .....	45
4.10.2	Pin assignment [X11] .....	45
4.11	FCT interfaces .....	46
4.11.1	Overview of interfaces .....	46
4.11.2	USB [X19] .....	46
4.11.3	Ethernet TCP/IP [X18] .....	47
4.12	Connection: I/O interface for STO [X40] .....	49
4.12.1	Plug [X40] .....	49
4.12.2	Pin assignment [X40] .....	49
4.12.3	Circuitry with use of the STO safety function [X40] .....	49
4.12.4	Circuitry without use of the STO safety function [X40] .....	49
4.13	Instructions on safe and EMC-compliant installation .....	51
4.13.1	Explanations and terms .....	51
4.13.2	General remarks on EMC .....	51
4.13.3	EMC areas: First and second environment .....	52
4.13.4	EMC-compliant wiring .....	53
4.13.5	Operation with long motor cables .....	55
4.13.6	ESD protection .....	55
<b>5</b>	<b>Commissioning .....</b>	<b>56</b>
5.1	General connection instructions .....	56
5.2	Tools / material .....	56
5.3	Connecting the motor .....	56

5.4	Connect motor controller CMMP-AS-...-M0 to the power supply .....	57
5.5	Connecting a PC .....	57
5.6	Check operating status .....	58
<b>6</b>	<b>Service functions and diagnostic messages .....</b>	<b>59</b>
6.1	Protective and service functions .....	59
6.1.1	Overview .....	59
6.1.2	Phases and mains failure detection .....	59
6.1.3	Overload current and short-circuit monitoring .....	59
6.1.4	Overvoltage monitoring for the intermediate circuit .....	59
6.1.5	Temperature monitoring for the heat sink .....	59
6.1.6	Monitoring of the motor .....	60
6.1.7	I2t monitoring .....	60
6.1.8	Power monitoring for the brake chopper .....	60
6.1.9	Commissioning status .....	61
6.1.10	Rapid discharge of the intermediate circuit .....	61
6.1.11	Detection of faults in conjunction with the functional safety engineering .....	61
6.2	Operating mode and diagnostic messages .....	61
6.2.1	Operation and display components .....	61
6.2.2	7-segment display .....	62
6.2.3	Acknowledgement of error messages .....	63
6.2.4	Diagnostic messages .....	63
<b>7</b>	<b>Maintenance, care, repair and replacement .....</b>	<b>64</b>
7.1	Maintenance and care .....	64
7.2	Repair .....	64
7.3	Replacement and disposal .....	64
7.3.1	Dismounting and installation .....	64
7.3.2	Disposal .....	64
<b>A</b>	<b>Technical appendix .....</b>	<b>65</b>
A.1	Technical data CMMP-AS-...-M0 .....	65
A.1.1	Interfaces .....	73
A.2	Supported encoders .....	79
<b>B</b>	<b>Diagnostic messages .....</b>	<b>81</b>
B.1	Explanations of the diagnostic messages .....	81
B.2	Diagnostic messages with instructions for fault clearance .....	82
<b>Index</b>	<b>.....</b>	<b>121</b>

**Instructions on this documentation**

This documentation is intended to help you safely work with the motor controller CMMP-AS-...-M0 and describes the mounting and installation processes.

**Target group**

This documentation is intended exclusively for technicians trained in control and automation technology, who have experience in installation, commissioning, programming and diagnostics of positioning systems.

**Product identification, versions**



This description refers to the following versions:

- CMMP-AS-...-M0 from Rev 01
- FCT plug-in CMMP-AS from Version 2.3.x.



**Note**

Before using a newer firmware version, check whether a newer version of the FCT plug-in or user documentation is available for it  
 Support Portal: → [www.festo.com/sp](http://www.festo.com/sp)

Rating plate (example)	Meaning	
	Type designation	CMMP-AS-C2-3A-M0
	Part number	1622901
	Serial number	XX
	Revision status	Rev XX
	Input data	100 ... 230 V AC ±10%
		50 ... 60 Hz 3 A
	Output data	0 ... 270 V AC
	0 ... 1000 Hz 2.5 A	
Max. ambient temperature	40 °C	

Tab. 1 Rating plate example CMMP-AS-C2-3A-M0

**Service**

Please consult your regional Festo contact if you have any technical problems.

**Specified standards/directives**

Issue status	
2006/42/EC	EN 60204-1:2006-06/A1:2009-02
2006/95/EC	EN 50178:1997-10
2004/108/EC	IEC 61131-2:2007-09
EN 61800-3:2004-12 + A1:2012-3	

Tab. 2 Standards/directives specified in the document

**Production time period**

On the type plate, the first 2 characters of the serial number indicate the production period in encrypted form (→ Tab. 1) The letter specifies the manufacturing year and the character behind it (number or letter) indicates the month of production.

Manufacturing year					
X = 2009	A = 2010	B = 2011	C = 2012	D = 2013	E = 2014
F = 2015	H = 2016	J = 2017	K = 2018	L = 2019	M = 2020

Tab. 3 Manufacturing year (20-year cycle)

Manufacturing month	
1	January
3	March
5	May
7	July
9	September
N	November
2	February
4	April
6	June
8	August
O	October
D	December

Tab. 4 Manufacturing month

**Type codes**

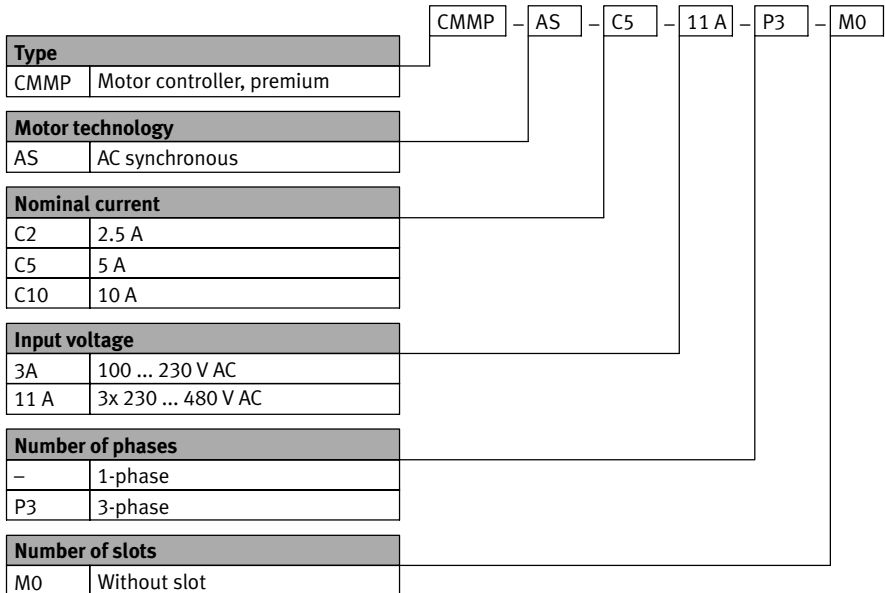

Fig. 1 Type codes

**Documentation**

You will find additional information on the motor controller in the following documentation:

<b>User documentation on the motor controller CMMP-AS-...-M0</b>	
<b>Name, type</b>	<b>Table of contents</b>
Hardware description, GDCP-CMMP-M0-HW-...	Mounting and installation of the motor controller CMMP-AS-...-M0 for all variants/output classes (1-phase, 3-phase), pin assignments, error messages, maintenance.
Function descriptions, GDCP-CMMP-M0-FW-...	Functional description (firmware) CMMP-AS-...-M0, Instructions on commissioning.
Description FHPP, GDCP-CMMP-M3/-M0-C-HP-...	Control and parameterisation of the motor controller via the FHPP Festo profile. <ul style="list-style-type: none"> <li>– Motor controller CMMP-AS-...-M3 with the following field-busses: CANopen, PROFINET, PROFIBUS, EtherNet/IP, DeviceNet, EtherCAT.</li> <li>– Motor controller CMMP-AS-...-M0 with fieldbus CANopen.</li> </ul>
Description CiA 402 (DS 402), GDCP-CMMP-M3/-M0-C-CO-...	Control and parameterisation of the motor controller via the device profile CiA 402 (DS 402) <ul style="list-style-type: none"> <li>– Motor controller CMMP-AS-...-M3 with the following field-busses: CANopen and EtherCAT.</li> <li>– Motor controller CMMP-AS-...-M0 with fieldbus CANopen.</li> </ul>
Description CAM-Editor, P.BE-CMMP-CAM-SW-...	Cam disc function (CAM) of the motor controller CMMP-AS-...-M3/-M0.
Description of the safety function STO, GDCP-CMMP-AS-M0-S1-...	Functional safety engineering for the motor controller CMMP-AS-...-M0 with the integrated safety function STO.
Help for the FCT plug-in CMMP-AS	User interface and functions of the CMMP-AS plug-in for the Festo Configuration Tool → <a href="http://www.festo.com/sp">www.festo.com/sp</a> .

Tab. 5 Documentation on the motor controller CMMP-AS-...-M0



# 1 Safety and requirements for product use

## 1.1 Safety

### 1.1.1 Safety instructions for commissioning, repair and de-commissioning



#### **Warning**

Danger of electric shock.

- When cables are not mounted to the plugs [X6] and [X9].
- When connecting cables are disconnected when powered.

Touching live parts can result in severe injuries and even death.

The product may only be operated in a built-in status and when all protective measures have been initiated.

Before touching live parts during maintenance, repair and cleaning work and when there have been long service interruptions:

1. Switch off power to the electrical equipment via the mains switch and secure it against being switched on again.
2. After switch-off, wait at least 5 minutes discharge time and check that power is turned off before accessing the controller.



The safety functions do not protect against electric shock but only against dangerous movements!



#### **Note**

Danger from unexpected movement of the motor or axis.

- Make sure that the movement does not endanger anyone.
- Perform a risk assessment in accordance with the EC machinery directive.
- Based on this risk assessment, design the safety system for the entire machine, taking into account all integrated components. This also includes the electric drives.
- Bypassing safety equipment is impermissible.

### 1.1.2 Protection against electric shock through protective extra-low voltage (PELV)



#### Warning

- Use for the electrical power supply only PELV circuits in accordance with EN 60204-1 (Protective Extra-Low Voltage, PELV). Also take into account the general requirements for PELV circuits in accordance with EN 60204-1.
- Use only power sources which guarantee reliable electrical isolation of the operating voltage as per EN 60204-1.

Through the use of PELV circuits, protection from electric shock (protection from direct and indirect contact) in accordance with EN 60204-1 is ensured (Electrical equipment of machines. General requirements).

### 1.1.3 Intended use

The CMMP-AS-...-M0 is intended for ...

- Use in control cabinets for power supply to AC servo motors and their regulation of torques (current), rotational speed and position.

The CMMP-AS-...-M0 is intended for installation in machines or automated systems and may be used only as follows:

- in excellent technical condition,
- in original status without unauthorised modifications,
- within the limits of the product defined by the technical data (→ Appendix A Technical appendix),
- in an industrial environment.

The product is intended for use in industrial areas. When used outside an industrial environment, e.g. in commercial and mixed residential areas, measures for radio interference suppression may be necessary.



#### Note

In the event of damage caused by unauthorised manipulation or other than intended use, the guarantee is invalidated and the manufacturer is not liable for damages.

## 1.2 Requirements for product use

- Make this documentation available to the design engineer, installer and personnel responsible for commissioning the machine or system in which this product is used.
- Make sure that the specifications of the documentation are always complied with. Also consider the documentation for the other components and modules.
- Take into consideration the legal regulations applicable for the destination, as well as:
  - regulations and standards,
  - regulations of the testing organizations and insurers,
  - national specifications.

### 1.2.1 Transport and storage conditions

- Protect the product during transport and storage from impermissible burdens, such as:
  - mechanical loads,
  - impermissible temperatures,
  - moisture,
  - aggressive atmospheres.
- Store and transport the product in its original packaging. The original packaging offers sufficient protection from typical stresses.

### 1.2.2 Technical requirements

General conditions for the correct and safe use of the product, which must be observed at all times:

- Comply with the connection and environmental conditions of the product (→ Appendix A) and all connected components specified in the technical data.  
Only compliance with the limit values or load limits will enable operation of the product in compliance with the relevant safety regulations.
- Observe the instructions and warnings in this documentation.

### 1.2.3 Qualification of the specialists (requirements for the personnel)

The product may only be placed in operation by a qualified electrotechnician who is familiar with:

- the installation and operation of electrical control systems,
- the applicable regulations for operating safety-engineered systems,
- the applicable regulations for accident protection and occupational safety, and
- the documentation for the product.

### 1.2.4 Range of application and certifications

Standards and test values, which the product complies with and fulfils, can be found in the “Technical data” section (→ Appendix A). The product-relevant EU directives can be found in the declaration of conformity.



Certificates and declaration of conformity on this product can be found at  
→ [www.festo.com/sp](http://www.festo.com/sp).

The current revisions and special configurations of earlier revisions (order code ...-C1) of the product have been certified by Underwriters Laboratories Inc. (UL) for the USA and Canada. These are marked as follows:



UL Listing Mark for Canada and the United States



**Note**

Observe the following if the UL requirements are to be complied with in your application:

- Rules for observing the UL certification can be found in the separate UL special documentation. The technical data stated therein take priority.
- The technical data in this documentation may show values deviating from this.

Certain configurations of earlier revisions of the product have been certified by Underwriters Laboratories Inc. (UL) for the USA. These are marked as follows:



UL Listing Mark for the United States

## 2 Product overview

### 2.1 The entire system for the CMMP-AS-...-M0

A motor controller CMMP-AS-...-M0 entire system is shown in → Fig. 2.1 → Page 14. For operation of the motor controller, the following components are required:

- Mains power switch
- FI circuit breaker (RCD), all-current sensitive 300 mA
- Automatic circuit breaker
- Power supply 24 V DC
- Motor controller CMMP-AS-...-M0
- Motor with motor and encoder cables

A Windows PC with USB or Ethernet connection is required for parametrisation.



Observe the instructions regarding mains fuses in → Chapter 4.

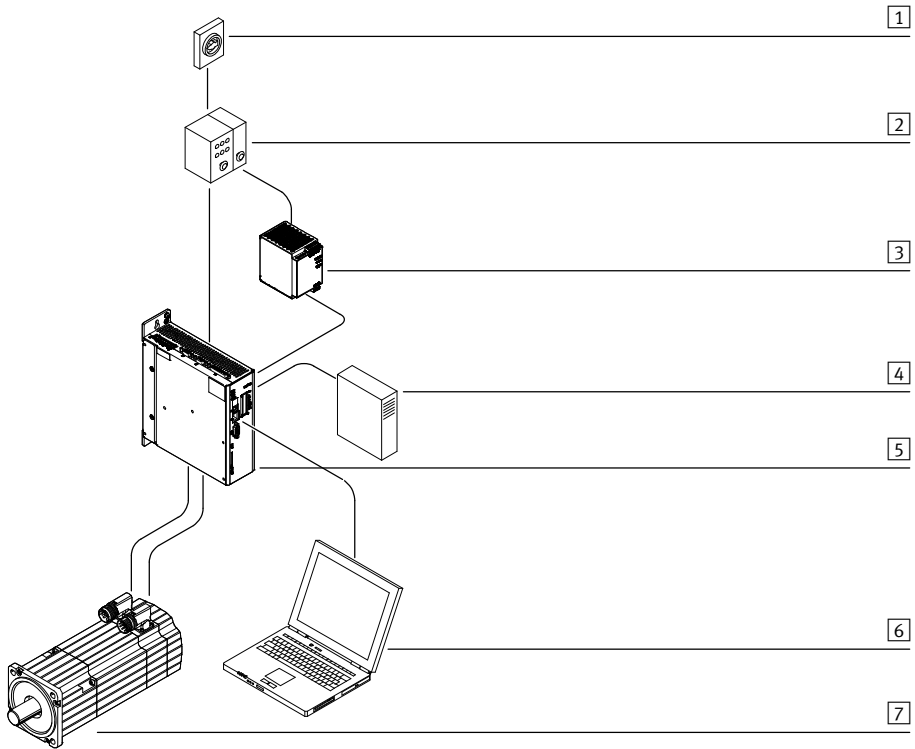

- |   |                                     |   |                                   |
|---|-------------------------------------|---|-----------------------------------|
| 1 | Power switch                        | 5 | Motor controller CMMP-AS-...-M0   |
| 2 | Fuse                                | 6 | PC                                |
| 3 | Power pack for logic voltage        | 7 | Motor (e.g. EMMS-AS with encoder) |
| 4 | Optional: external braking resistor |   |                                   |

Fig. 2.1 Complete structure CMMP-AS-...-M0 with motor and PC

## 2.2 Scope of delivery

The delivery includes:

Scope of delivery	
Motor controller	CMMP-AS-...-M0
Operator package	CD
	Brief description
Assortment of plugs	NEKM-C-7, NEKM-C-8

Tab. 2.1 Scope of delivery

### 2.3 Device view

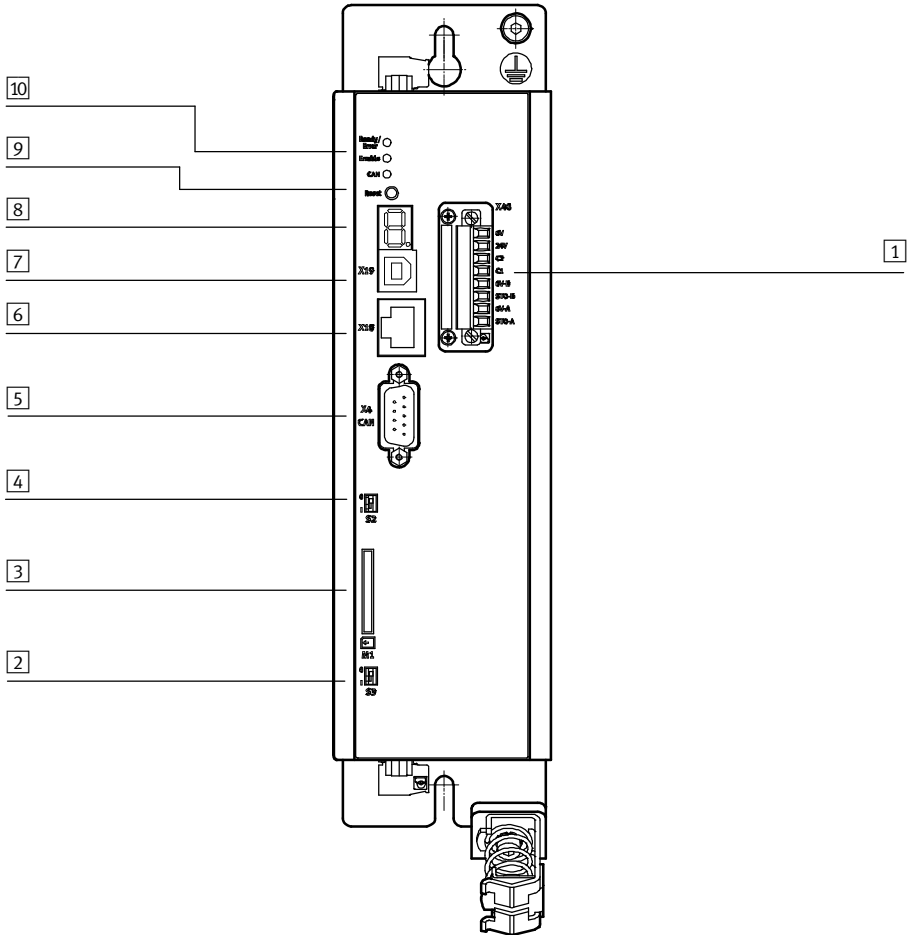

- |   |   |    |                          |
|---|---|----|--------------------------|
| 1 | Digital I/O interface for control of the STO function [X40] | 5  | CANopen interface [X4]   |
| 2 | Activation of firmware download [S3]                        | 6  | Ethernet interface [X18] |
| 3 | SD-/MMC card slot [M1]                                      | 7  | USB interface [X19]      |
| 4 | Activation of CANopen terminating resistor [S2]             | 8  | 7-segment display        |
|   |   | 9  | Reset button             |
|   |   | 10 | LEDs                     |

Fig. 2.2 Motor controller CMMP-AS-...-M0: Front view

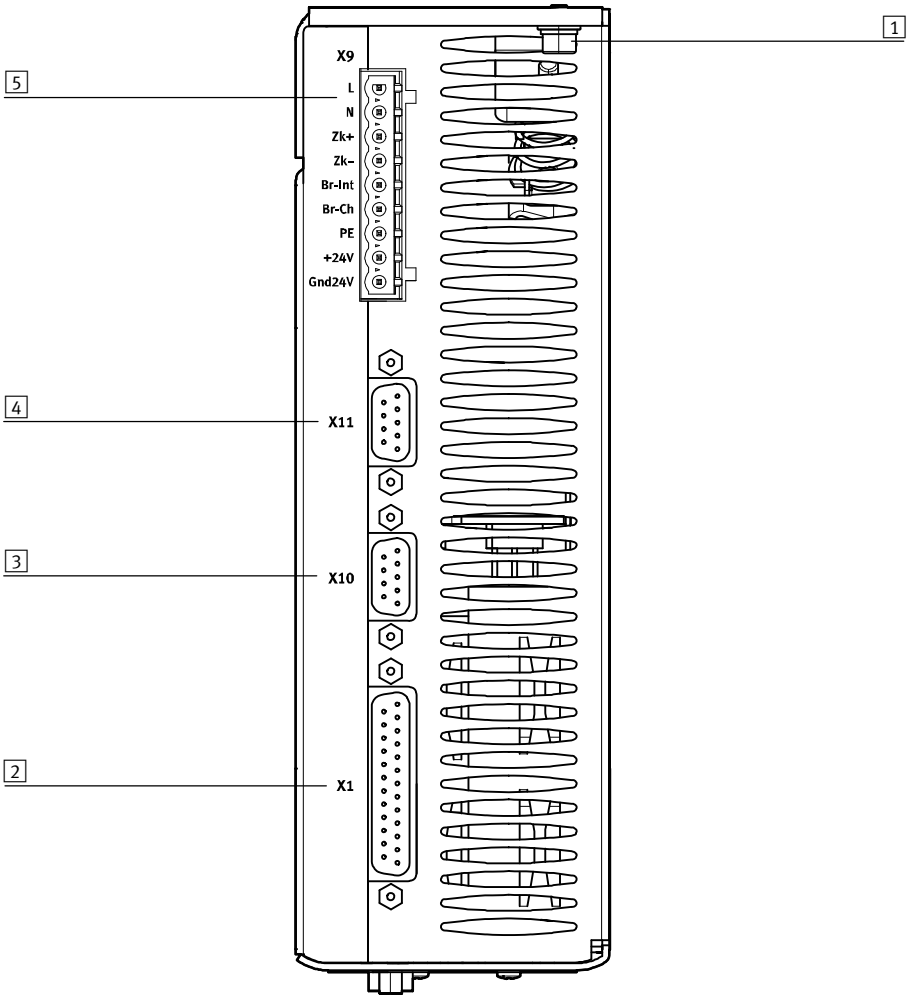

- |  |   |
|--|---|
| <b>1</b> PE connection                   | <b>4</b> Incremental encoder output [X11] |
| <b>2</b> I/O communication [X1]          | <b>5</b> Power supply [X9]                |
| <b>3</b> Incremental encoder input [X10] |   |

Fig. 2.3 Motor controller CMMP-AS-...-3A-M0: Top view



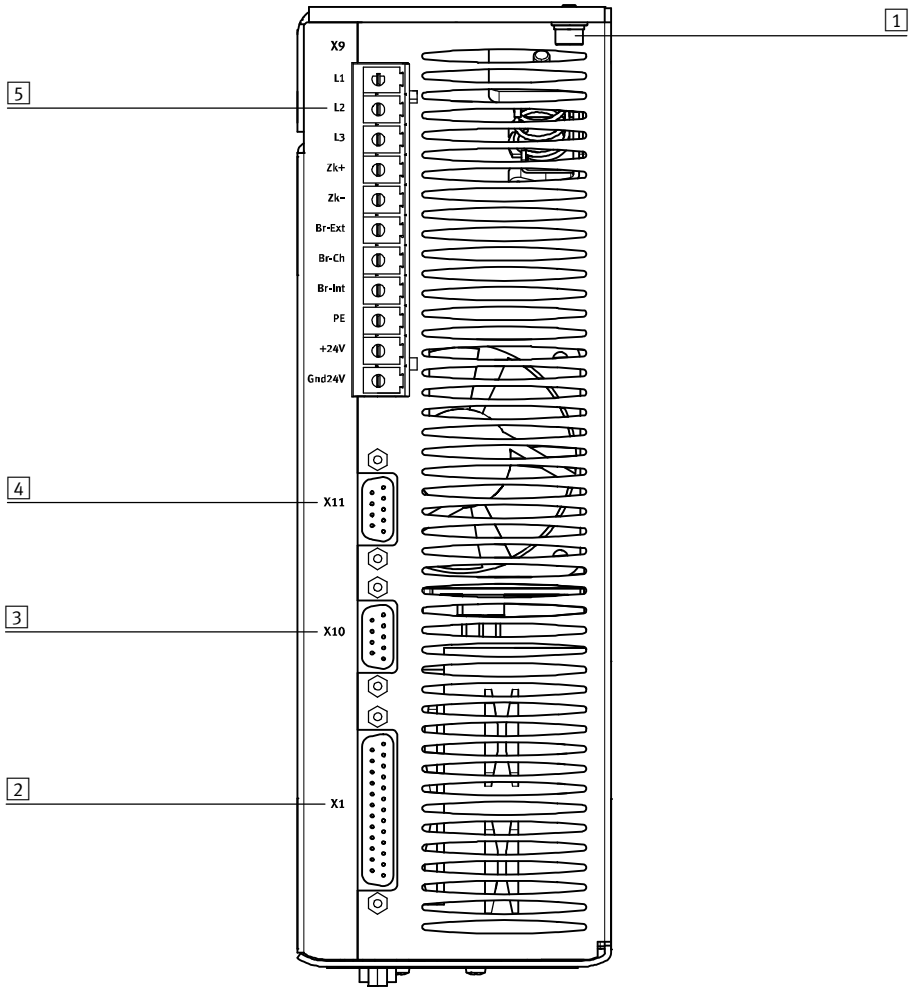

- |  |   |
|--|---|
| <b>1</b> PE connection                   | <b>4</b> Incremental encoder output [X11] |
| <b>2</b> I/O communication [X1]          | <b>5</b> Power supply [X9]                |
| <b>3</b> Incremental encoder input [X10] |   |

Fig. 2.4 Motor controller CMMP-AS-...-11A-P3-M0: Top view

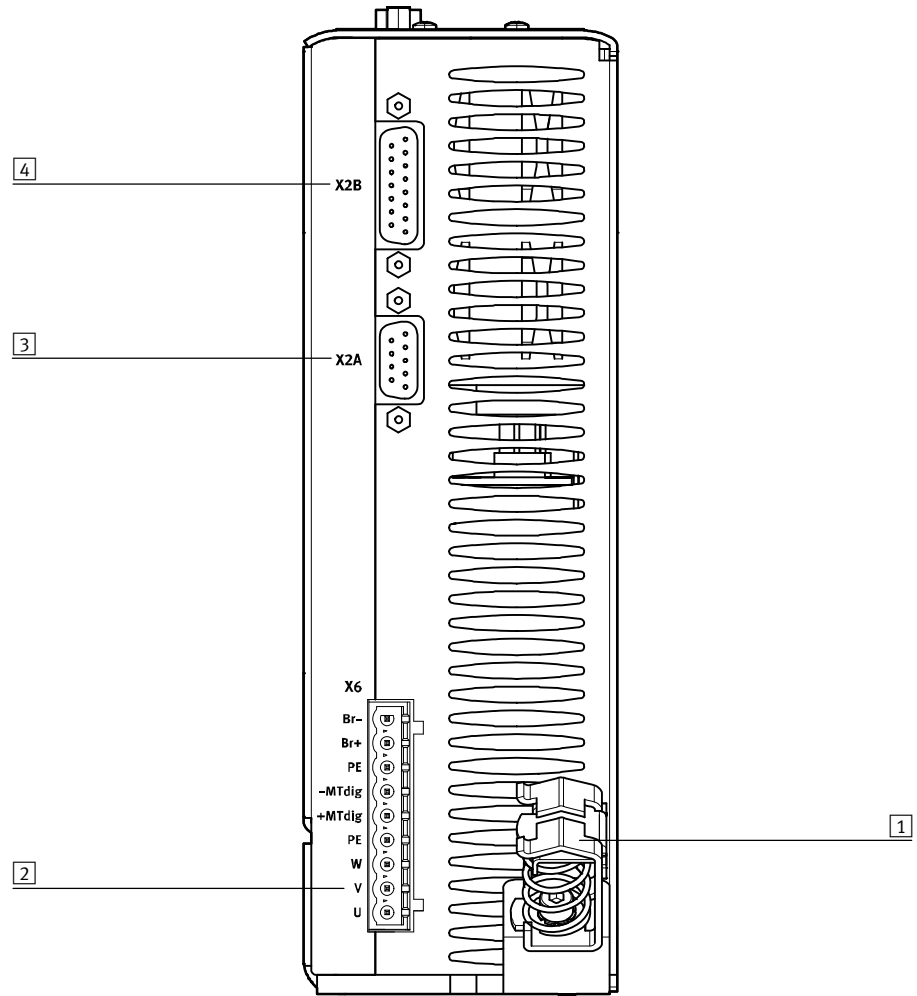

- 1 Spring-loaded terminal connection for the outer shield of the motor cable
- 2 Motor connection [X6]
- 3 Connection for the resolver [X2A]
- 4 Connection for the encoder [X2B]

Fig. 2.5 Motor controller CMMP-AS-...-M0: Bottom view

## 3 Mechanical installation

### 3.1 Important notes



**Note**

Proceed carefully when mounting. During mounting and subsequent operation of the drive, ensure that no metal shavings, metal dust or mounting parts (screws, nuts, pieces of wire) fall into the motor controller.



**Note**

The motor controllers CMMP-AS-...-M0

- Use only as installed devices for control cabinet mounting.
- Mounting orientation with the power supply [X9] on top.
- Mount it with the clip on the mounting plate.
- Installation clearances:  
For sufficient ventilation of the device, a minimum clearance of 100 mm to other sub-assemblies is required above and below the device.
- An installation clearance of 150 mm underneath the device is recommended for optimum wiring of the motor or encoder cable!
- The motor controllers of the CMMP-AS-...-M0 family are designed in such a way that they can be mounted directly on a heat-dissipating mounting plate if used as intended and installed correctly. We wish to point out that excessive heating can lead to premature aging and/or damage to the device. With high thermal stress on the motor controller CMMP-AS-...-M0, a mounting distance (→ Fig. 3.2) is recommended!

## 3.2 Mounting



Observe the safety instructions → Chapter 1 during mounting and installation work.



### Please note

#### Damage to the motor controller due to incorrect handling.

- Switch off the supply voltage before mounting and installation work. Switch on supply voltage only when mounting and installation work are completely finished.
- Observe the handling specifications for electrostatically sensitive devices. Do not touch the printed circuit board and the pins of the manifold rail in the motor controller.



### 3.2.1 Motor controller

Mounting clips are located at the top and bottom of the motor controller CMMP-AS-...-M0. They are used to attach the motor controller vertically to a mounting plate. The clips are part of the radiator profile, ensuring an optimal heat transfer to the mounting plate.



Please use size M5 screws to attach the motor controller CMMP-AS-...-M0.

3 Mechanical installation

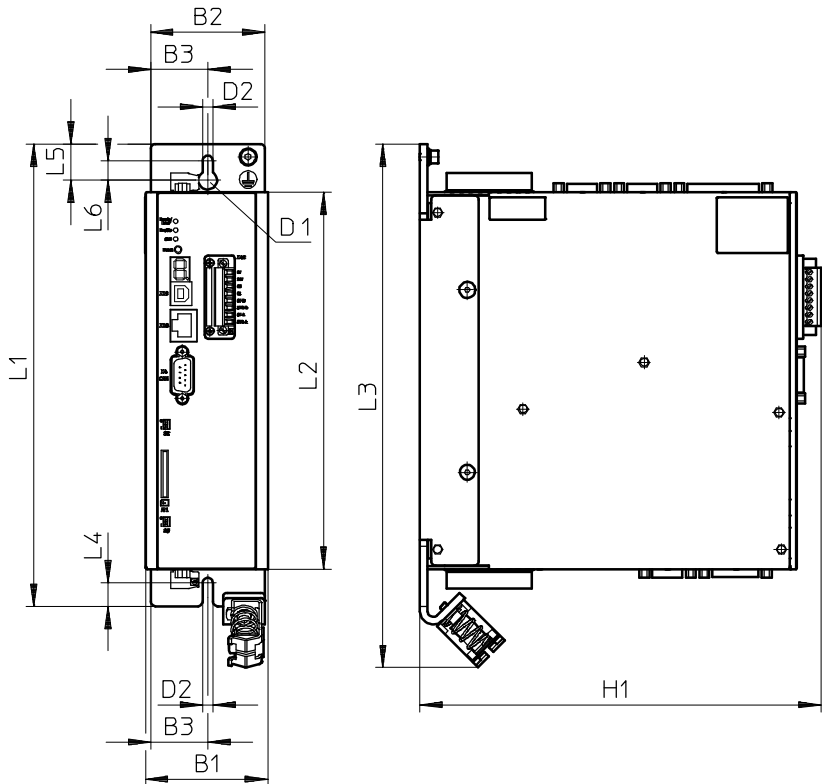

Fig. 3.1 Motor controller CMMP-AS-...-M0: Mounting plate

CMMP-AS-...		H1	L1	L2	L3	L4	L5	L6	B1	B2	B3	D1	D2
-3A-M0	[mm]	207	248	202	281	12.5	19	10.5	66	61	30.7	10	5.5
-11A-P3-M0	[mm]	247	297	252	330	12.5	19	10.5	79	75	37.5	10	5.5

Tab. 3.1 Motor controller CMMP-AS-...-M0: Dimensions table

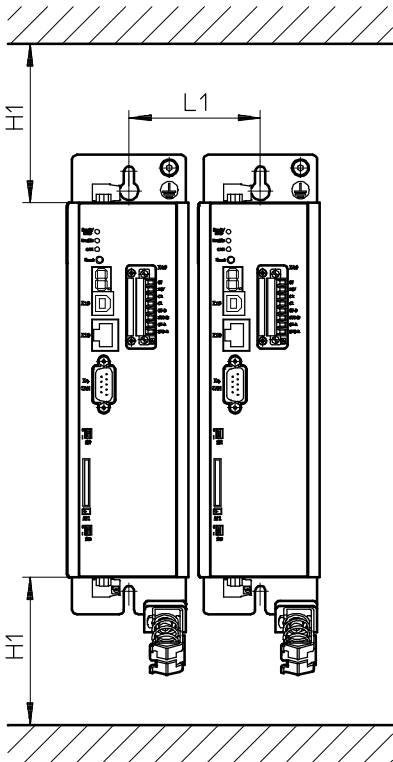

Fig. 3.2 Motor controller CMMP-AS-...-M0: Mounting distance and installation clearance

Motor controller		L1	H11)
CMMP-AS-...-3A-M0	[mm]	≥ 71	≥ 100
CMMP-AS-...-11A-P3-M0	[mm]	≥ 85	≥ 100

1) An installation clearance of 150 mm underneath the device is recommended for optimum wiring of the motor or encoder cable!

Tab. 3.2 Motor controller CMMP-AS-...-M0: Mounting distance and installation clearance

## 4 Electrical installation

### 4.1 Safety instructions



#### Warning

##### Danger of electric shock

Motor controllers are devices with increased leakage current (> 3.5 mA). If wiring is incorrect or the device is defective, high voltage can occur on the housing, which can result in serious injury or even death if the housing is touched.

- Before commissioning, also for brief measuring and test purposes, connect the PE protective conductor:
  - to the earthing screw of the controller housing
  - to pin PE [X9], power supply.  
The cross section of the protective conductor at PE [X9] must correspond at least to the cross section of the external conductor L [X9].
- Observe the regulations of EN 60204-1 for the protective earthing.



#### Warning

##### Danger of electric shock

- when the module or cover plate is not mounted on the card slot [EXT]
- when cables are not mounted to the plugs [X6] and [X9]
- if connecting cables are disconnected when powered.

Touching live parts causes severe injuries and can lead to death. Before mounting and installation work:

1. Switch off power to the electrical equipment via the mains switch and secure it against being switched on again.
2. After switch-off, wait at least 5 minutes discharge time and check that power is turned off before accessing the controller.



#### Warning

##### Danger of electric shock

This product can cause a DC current in the protective ground conductor. In cases where an error current protection unit (RCD) or an error current monitoring device (RCM) is used to protect against direct or indirect contact, only the Type B kind of RCD or RCM is permitted on the power supply side of this product.





### Caution

#### Danger from unexpected movement

Faulty pre-assembled lines may destroy the electronics and trigger unexpected movements of the motor.

- When wiring the system, use only the supplied plug connectors and preferably the cables listed in the catalogue as accessories.  
→ [www.festo.com/catalogue](http://www.festo.com/catalogue)
- Lay all flexible lines so that they are free of kinks and free of mechanical stress; if necessary use chain link trunking.



### Note

ESD (electrostatic discharge) can cause damage to the device or other system parts at plug connectors that are not used.

- Before installation: Earth the system parts and use appropriate ESD equipment (e.g. shoes, earthing straps etc.).
- After installation: Seal unassigned Sub-D plug connectors with protective caps (available at authorized dealers).
- Observe the handling specifications for electrostatically sensitive devices.





## 4.2 Allocation of the plug connectors

The motor controller CMMP-AS-...-M0 is connected to the supply voltage, the motor, the external braking resistor and the holding brake in accordance with the following circuit diagrams.

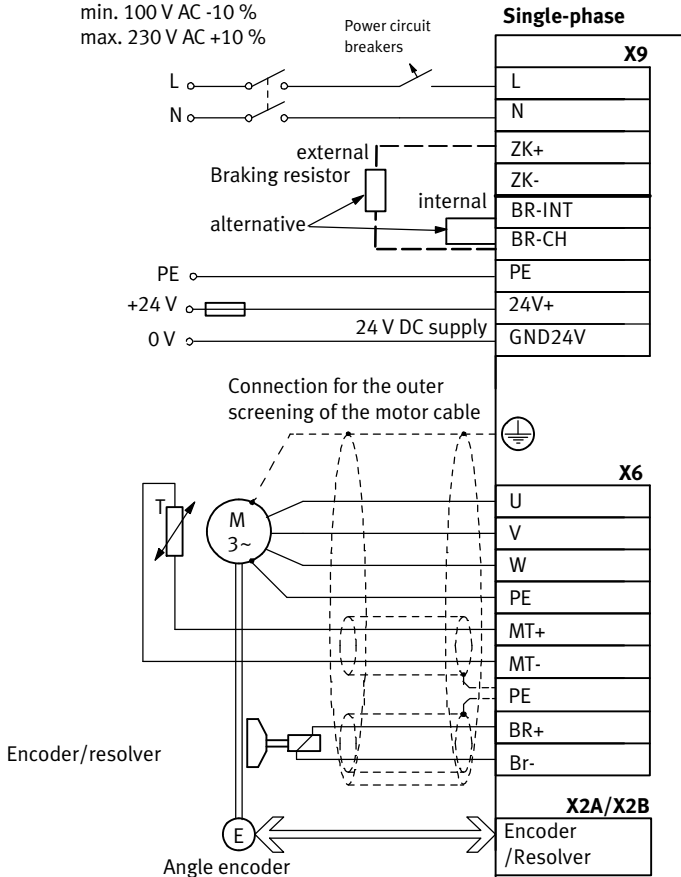

Fig. 4.1 CMMP-AS-...-3A-M0: Single-phase connection to the supply voltage and the motor

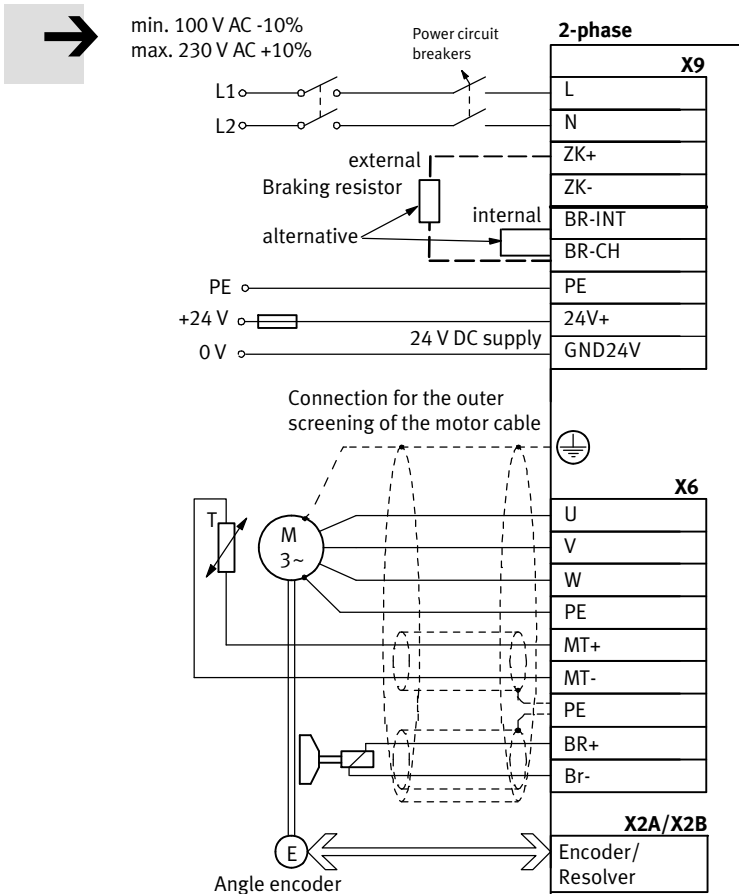

Fig. 4.2 CMMP-AS-...-3A-M0: Dual-phase connection L1/L2 to the supply voltage and the motor

**Note**  
 The **maximum voltage** of 230 V AC +10 % must be present between the **external conductors**.  
 In typical European low voltage networks that have a nominal star voltage of 230 V, a mesh voltage of approx. 400 V develops between two external conductors, which could result in damage to the motor controller!

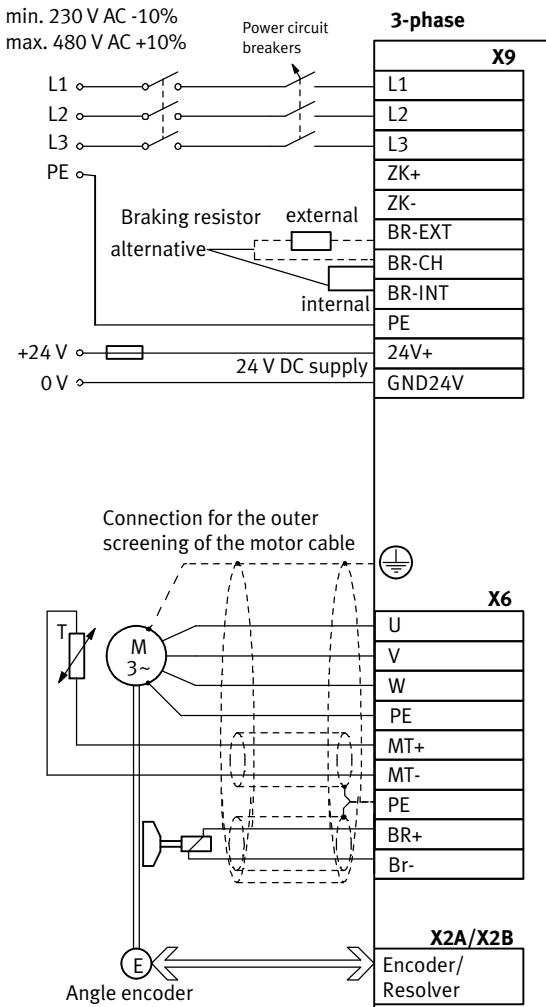

Fig. 4.3 CMMP-AS-...-11A-M0: Triple-phase connection to the supply voltage and the motor

The power supply cables for the power end stage are alternatively connected to the following terminals:

<b>Power end stage supply</b>		
Observe instructions in chapter → 4.8.5		
AC supply	L, N	for single-phase motor controllers
	L1, L2, L3	for three-phase motor controllers
DC supply	ZK+, ZK-	

Tab. 4.1 Connection of power supply cables

<b>Motor temperature switch</b>		
PTC or N/C contact/ N/O contact <sup>1)</sup> (e.g. KTY81)	MT+, MT-; [X6]	if this is carried together with the motor phases in one cable
Analogue temperature sensor <sup>1)</sup>	MT+, MT-; [X2A] or [X2B]	

1) EMMS-AS motors have a PTC

Tab. 4.2 Connection of the motor temperature switch



**Note**  
Temperature sensors must be sufficiently isolated from the motor winding.

The connection of the encoder/resolver via the Sub-D plug connector to [X2A] or [X2B] is roughly shown diagrammatically in → Fig. 4.1,

→ Fig. 4.2 and → Fig. 4.3.



**Note**  
If the polarity of the operating voltage connections is reversed, or if the operating voltage is too high or the operating voltage and motor connections are reversed, the motor controller CMMP-AS-...-M0 will be damaged.

### 4.3 Connection: I/O communication [X1]

#### 4.3.1 Plug [X1]:

Motor controller	Design on the device	Counterplug
CMMP-AS-...-M0	Sub-D plug connector, 25-pin, socket	Sub-D plug connector, 25-pin, pins

Tab. 4.3 Plug design [X1]

#### 4.3.2 Pin assignment [X1]

See Technical data → section A.1.1 for connected loads of the inputs and outputs.

In the firmware factory setting (delivery status) the control interface for CANopen is parameterised (bus settings via DIL switch) to enable a device to be replaced without FCT → Tab. 4.4.

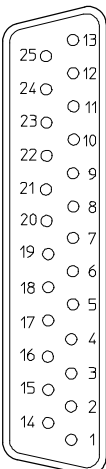
[X1]	Pin no.	Designation	Specification
	13	DOUT3	Output freely parameterisable, optionally parameterisable as DIN11
	25	DOUT2	Output freely parameterisable, optionally parameterisable as DIN10
	12	DOUT1	Output freely parameterisable
	24	DOUT0	Controller ready, output permanently assigned
	11	DIN 9	Fieldbus data profile (CiA 402, FHPP), input freely parameterisable
	23	DIN 8	Fieldbus activation communication, input freely parameterisable
	10	DIN7	Limit switch 1 (blocks $n < 0$ ), input permanently assigned
	22	DIN6	Limit switch 0 (blocks $n > 0$ ), input permanently assigned
	9	DIN5	Controller enable, input permanently assigned
	21	DIN4	End stage enable, input permanently assigned
	8	DIN 3	Fieldbus offset node number bit 3, input freely parameterisable
	20	DIN 2	Fieldbus offset node number bit 2, input freely parameterisable
	7	DIN 1	Fieldbus offset node number bit 1, input freely parameterisable
	19	DIN 0	Fieldbus offset node number bit 0, input freely parameterisable
	6	GND24	Reference potential for digital I/Os
	18	+24 V	24 V output
	5	AOUT1	Analogue output freely parameterisable
	17	AOUT0	Analogue output freely parameterisable
	4	+VREF	Reference output for setpoint potentiometer
	16	DIN13	Fieldbus transmission rate bit 1, optionally parameterisable as AIN2 <sup>1)</sup>
	3	DIN12	Fieldbus transmission rate bit 0, optionally parameterisable as AIN1 <sup>1)</sup>
	15	#AIN0	Setpoint input 0, differential analogue input
	2	AIN0	
	14	AGND	Reference potential for analogue signals
	1	AGND	Screening for analogue signals, AGND

1) Configuration with FCT. Observe not → Abschnitt 4.3.3.

Tab. 4.4 Pin assignment: I/O communication [X1] (firmware factory setting)

The standard assignment of the I/O interface in the FCT corresponds to → Tab. 4.5.

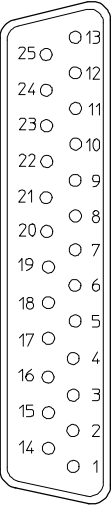
[X1]	Pin no.	Designation	Specification
	13	DOUT3	Following error, output freely parameterisable, optionally parameterisable as DIN11
	25	DOUT2	Brake unlocked, output freely parameterisable, optionally parameterisable as DIN10
	12	DOUT1	Motion Complete, Output freely parameterisable
	24	DOUT0	Controller ready, output permanently assigned
	11	DIN 9	Flying measurement (sample)/reference switch, input freely parameterisable
	23	DIN 8	Start positioning task, input freely parameterisable
	10	DIN7	Limit switch 1 (blocks $n < 0$ ), input permanently assigned
	22	DIN6	Limit switch 0 (blocks $n > 0$ ), input permanently assigned
	9	DIN5	Controller enable, input permanently assigned
	21	DIN4	End stage enable, input permanently assigned
	8	DIN 3	Position selector bit 3, input freely parameterisable
	20	DIN 2	Position selector bit 2, input freely parameterisable
	7	DIN 1	Position selector bit 1, input freely parameterisable
	19	DIN 0	Position selector bit 0, input freely parameterisable
	6	GND24	Reference potential for digital I/Os
	18	+24 V	24 V output
	5	AOUT1	Position setpoint value, analogue output freely parameterisable
	17	AOUT0	Speed setpoint value, analogue output freely parameterisable
	4	+VREF	Reference output for setpoint potentiometer
	16	AIN13	Setpoint input 2, single ended analogue input, optionally parameterisable as DIN13 <sup>1)</sup>
3	AIN12	Setpoint input 1, single ended analogue input, optionally parameterisable as DIN12 <sup>1)</sup>	
15	#AIN0	Setpoint input 0, differential analogue input	
2	AIN0		
14	AGND	Reference potential for analogue signals	
1	AGND	Screening for analogue signals, AGND	

1) Configuration with FCT. Observe not → Section 4.3.3.

Tab. 4.5 Pin assignment: I/O communication [X1] (FCT factory setting)

### 4.3.3 Use analogue inputs as digital inputs

If the digital inputs AIN1 and ANI2 are used as digital inputs, then a ground reference from AGND to GND24 at plug X1 pins 14 and 6 must be established.



#### Note

Connecting AGND to GND24 renders the electronics overvoltage protection inoperable.

Controller

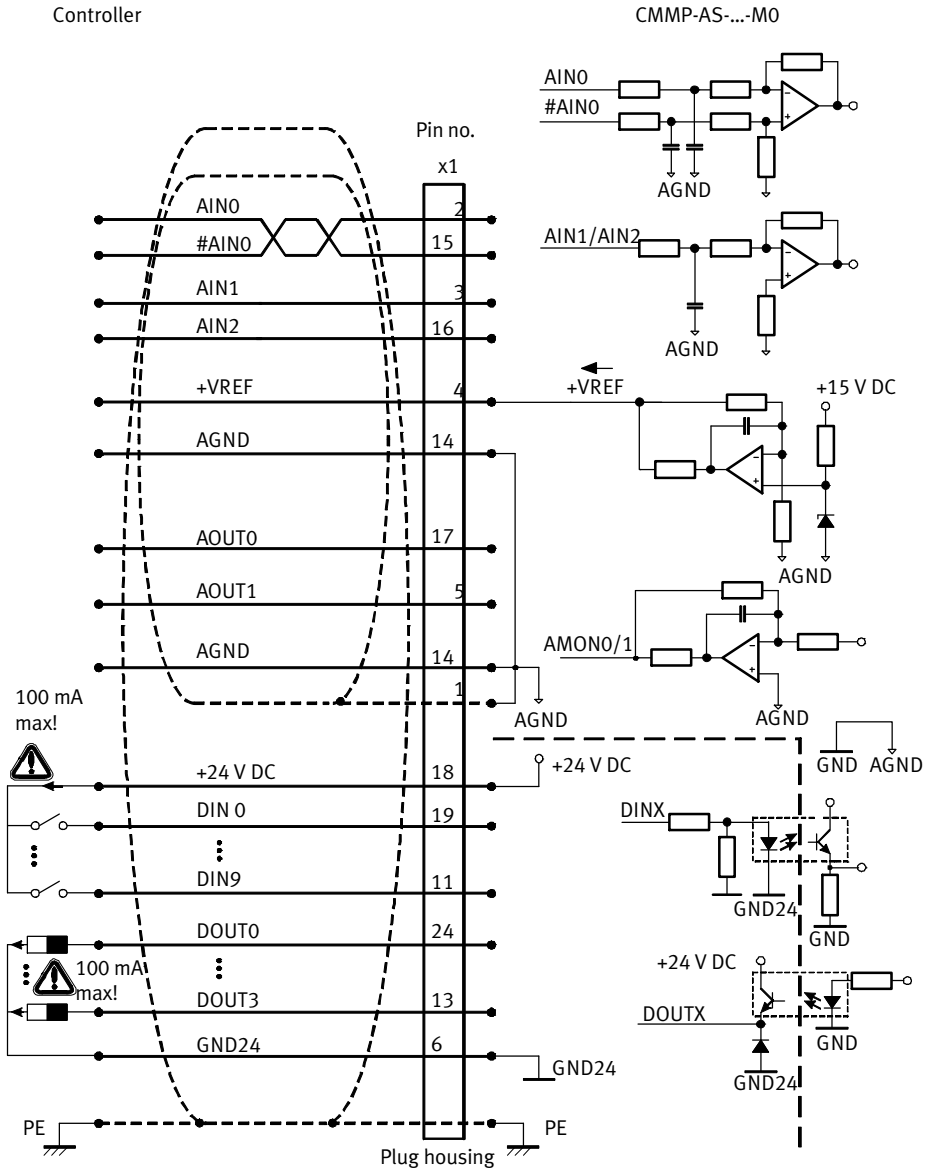

Fig. 4.4 Basic circuit diagram of connection [X1]



Control cable and Sub-D plug connector → [www.festo.com/catalogue](http://www.festo.com/catalogue).

## 4.4 Connection: Resolver [X2A]

### 4.4.1 Plug [X2A]

Motor controller	Design on the device	Counterplug
CMMP-AS-...-M0	Sub-D plug connector, 9-pin, socket	Sub-D plug connector, 9-pin, pins

Tab. 4.6 Plug design [X2A]

### 4.4.2 Pin assignment [X2A]

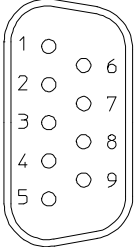
[X2A]	Pin no.	Designation	Value	Specification
	1	S2	3.5 V <sub>eff</sub> 5-10 kHz R <sub>i</sub> > 5 kΩ	SINE tracking signal, differential
	6	S4		
	2	S1	3.5 V <sub>eff</sub> 5-10 kHz R <sub>i</sub> > 5 kΩ	COSINE tracking signal, differential
	7	S3		
	3	AGND	0 V	Screening for signal pairs (inner screening)
	8	MT-	GND	Reference potential for temperature sensor
	4	R1	7 V <sub>eff</sub> 5-10 kHz I <sub>A</sub> ≤ 150 mA <sub>eff</sub>	Carrier signal for resolver
	9	R2	GND	
	5	MT+	+3.3 V R <sub>i</sub> = 2 kΩ	Temperature sensor, motor temperature, N/C contact, PTC, KTY ...

Tab. 4.7 Pin assignment [X2A]

The outer screening must always be connected to the PE (plug housing) of the motor controller. The inner screenings must be placed on one side on the motor controller CMMP-AS-...-M0 on PIN3 of [X2A].



## 4.5 Connection: Encoder [X2B]

### 4.5.1 Plug [X2B]

Motor controller	Design on the device	Counterplug
CMMP-AS-...-M0	Sub-D plug connector, 15-pin, socket	Sub-D plug connector, 15-pin, pins

Tab. 4.8 Plug design [X2B]

### 4.5.2 Pin assignment [X2B]

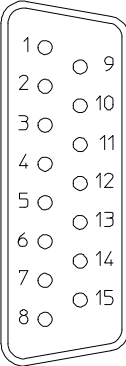
[X2B]	Pin no.	Designation	Value	Specification
	1	MT+	+3.3 V $R_I = 2 \text{ k}\Omega$	Temperature sensor, motor temperature, N/C contact, PTC, KTY ...
	2	U_SENS+	5 V ... 12 V	Sensor cable for the encoder supply
	9	U_SENS-	$R_I \approx 1 \text{ k}\Omega$	
	3	GND	0V	Reference potential for encoder supply and motor temperature sensor
	10	US	5 V/12 V $\pm 10\%$ $I_{\max} = 300 \text{ mA}$	
	4	R#	0.2 $V_{SS}$ ... 0.8 $V_{SS}$ $R_I \approx 120 \Omega$	Zero impulse tracking signal (differential) from high-resolution incremental encoder
	11	R		
	5	COS_Z1# 1)	1 $V_{SS}$ $R_I \approx 120 \Omega$	COSINE commutation signal (differential) from high-resolution increment generator
	12	COS_Z1 1)		
	6	SIN_Z1# 1)	1 $V_{SS}$ $R_I \approx 120 \Omega$	SINE commutation signal (differential) from high-resolution incremental encoder
	13	SIN_Z1 1)		
	7	COS_Z0# 1)	1 $V_{SS} \pm 10\%$ $R_I \approx 120 \Omega$	COSINE tracking signal (differential) from high-resolution incremental encoder
	14	COS_Z0 1)		
	8	SIN_Z0# 1)	1 $V_{SS} \pm 10\%$ $R_I \approx 120 \Omega$	SINE tracking signal (differential) from high-resolution incremental encoder
	15	SIN_Z0 1)		

1) Heidenhain encoder: A=SIN\_Z0; B=COS\_Z0, C=SIN\_Z1; D=COS\_Z1

Tab. 4.9 Pin assignment: Analogue incremental encoder – optional

The outer screening must always be connected to the PE (plug housing) of the motor controller.

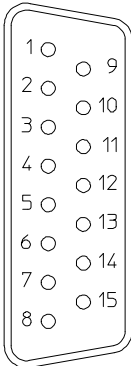
[X2B]	Pin no.	Designation	Value	Specification	
	1	MT+	+3.3 V $R_i = 2 \text{ k}\Omega$	Temperature sensor, motor temperature, N/C contact, PTC, KTY ...	
	2	U_SENS+	5 V ... 12 V	Sensor cable for the encoder supply	
	3	U_SENS-	$R_i \approx 1 \text{ k}\Omega$		
	4	US	5 V/12 V $\pm 10\%$ $I_{\max} = 300 \text{ mA}$	Operating voltage for high-resolution incremental encoder	
	5	GND	0V	Reference potential for encoder supply and motor temperature sensor	
	6	11	–		
	7	12	DATA	5 V <sub>SS</sub>	Bidirectional RS485 data cable (differential)
	8	13	DATA#	$R_i \approx 120 \Omega$	
	9	14	SCLK	5 V <sub>SS</sub>	RS485 clock output (differential)
	10	15	SCLK#	$R_i \approx 120 \Omega$	
	11	16	COS_Z0 1)	1 V <sub>SS</sub> $\pm 10\%$	COSINE tracking signal (differential) from high-resolution incremental encoder
	12	17	COS_Z0 1)#	$R_i \approx 120 \Omega$	
	13	18	SIN_Z0 1)	1 V <sub>SS</sub> $\pm 10\%$	SINE tracking signal (differential) from high-resolution incremental encoder
	14	19	SIN_Z0 1)#	$R_i \approx 120 \Omega$	

1) Heidenhain encoder: A=SIN\_Z0; B=COS\_Z0

Tab. 4.10 Pin assignment: Incremental encoder with serial interface, e.g. EnDat – optional

The outer screening must always be connected to the PE (plug housing) of the motor controller.

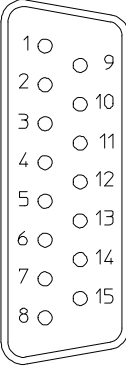
[X2B]	Pin no.	Designation	Value	Specification
	1	MT+	+3.3 V $R_I = 2 \text{ k}\Omega$	Temperature sensor, motor temperature, N/C contact, PTC, KTY ...
	9	U_SENS+	5 V ... 12 V	Sensor cable for the encoder supply
	2	U_SENS-	$R_I \approx 1 \text{ k}\Omega$	
	10	US	5 V/12 V / $\pm 10\%$ $I_{\max} = 300 \text{ mA}$	Operating voltage for high-resolution incremental encoder
	3	GND	0V	Reference potential for encoder supply and motor temperature sensor
	11	N	2 $V_{SS}$ ... 5 $V_{SS}$ $R_I \approx 120 \Omega$	Zero impulse RS422 (differential) from digital increment generator
	4	N#		
	12	H_U	0V/5V $R_I \approx 2 \text{ k}\Omega$	Phase U Hall sensor for commutation
	5	H_V	at VCC	Phase V Hall sensor for commutation
	13	H_W		Phase W Hall sensor for commutation
	6	-		
	14	A	2 $V_{SS}$ ... 5 $V_{SS}$ $R_I \approx 120 \Omega$	A tracking signal RS422 (differential) from digital incremental encoder
	7	A#		
	15	B	2 $V_{SS}$ ... 5 $V_{SS}$ $R_I \approx 120 \Omega$	B tracking signal RS422 (differential) from digital incremental encoder
	8	B#		

Tab. 4.11 Pin assignment: Digital incremental encoder – optional

The outer screening must always be connected to the PE (plug housing) of the motor controller.

## 4.6 Connection: CAN bus [X4]

### 4.6.1 Plug [X4]

Motor controller	Design on the device	Counterplug
CMMP-AS-...-M0	Sub-D plug connector, 9-pin, pin	Sub-D plug connector, 9-pin, socket

Tab. 4.12 Plug design [X4]

### 4.6.2 Pin assignment [X4]

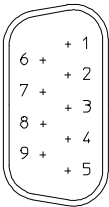
[X4]	Pin no.	Designation	Value	Description
	1	–	–	Not assigned
	6	CAN-GND	–	Galvanically connected to GND in the motor controller
	2	CAN-L	–	Negative CAN signal (dominant low)
	7	CAN-H	–	Positive CAN signal (dominant high)
	3	CAN-GND	–	Galvanically connected to GND in the motor controller
	8	–	–	Not assigned
	4	–	–	Not assigned
	9	–	–	Not assigned
	5	CAN shield	–	Screening

Tab. 4.13 Pin assignment for CAN-interface [X4]

## 4.7 Connection: Motor [X6]

### 4.7.1 Plug [X6]

CMMMP-AS-...	Design on the device / coding		Counterplug / coding	
...-C2-3A-M0	PHOENIX Contact	Pin 1 (BR-)	PHOENIX Contact	Pin 9 (U)
...-C5-3A-M0	MSTBA 2.5/9-G-5.08 BK		MSTB 2.5/9-ST-5.08 BK	
...-11A-P3-M0	PHOENIX Power-Combicon	-	PHOENIX Power-Combicon	-
...-C10-11A-P3-M0	PC 5/9-G-7.62 BK		PC 5/9-ST-7.62 BK	

Tab. 4.14 Plug design [X6]

### 4.7.2 Pin assignment [X6]

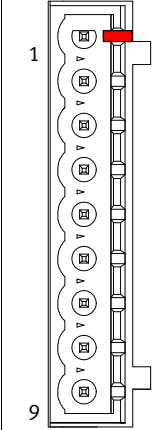
[X6]1)	Pin no.	Designation	Value	Specification
	1	Br-	0 V brake	Holding brake (motor), signal level dependent on switching status, high-side/low-side switch
	2	BR+	24 V brake	
	3	PE	PE	Cable shield for the holding brake and the temperature sensor (with Festo cables: n.c.)
	4	-MTdig	GND	Motor temperature sensor, N/C contact, N/O contact, PTC, KTY ...
	5	+MTdig	+3.3 V 5 mA	
	6	PE	PE	Protective earth conductor from the motor
	7	W	Technical data → Tab. A.9	Connection of the three motor phases
	8	V		
	9	U		

1) Representation of the plug on the device of the motor controller CMMMP-AS-...-3A-M0

Tab. 4.15 Pin assignment [X6] connection: Motor



The shielding for the motor cable must also be attached to the housing of the motor controller (spring clip: Fig. 2.5 → Page 18).

A motor holding brake can be connected to terminals BR+ and BR-. The locking brake is supplied from the logic supply of the motor controller. The maximum output current provided by the CMMMP-AS-...-M0 motor controller must be observed.



To release the holding brake, care must be taken to maintain the voltage tolerances at the holding brake connection terminals.

Also observe the specifications in Tab. A.4 → Page 66.

It may be necessary to insert a relay between the device and the holding brake, as shown in Fig. 4.5 → Page 38:

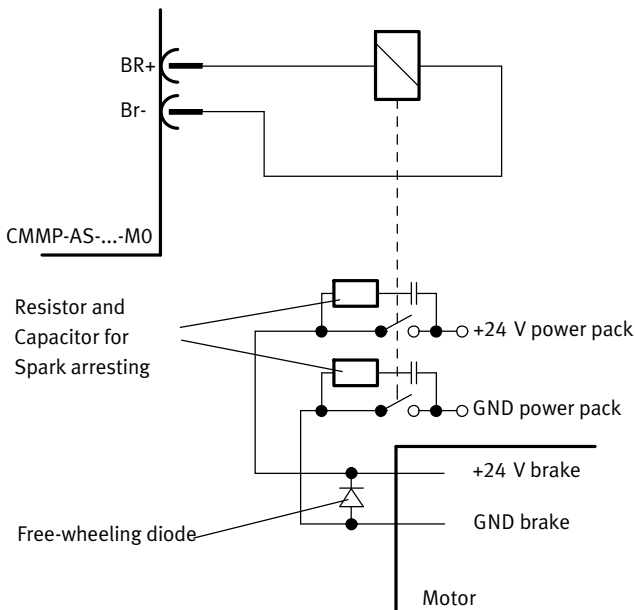

Fig. 4.5 Connecting a high-current holding brake to the device



High voltages with spark formation are created when inductive direct currents are connected via relays. For interference suppression, we recommend integrated RC interference suppressors, e.g. from Evox RIFA, designation: PMR205AC6470M022 (RC element with 22 Ω in series with 0.47 μF).

## 4.8 Connection: Voltage supply [X9]

The motor controller CMMP-AS-...-M0 receives its 24 V DC power supply for the control electronics via the plug connector [X9].

The main power supply for the motor controllers CMMP-AS-...-3A-M0 is 1-phase and for the motor controllers CMMP-AS-...-11A-P3-M0 3-phase.

### 4.8.1 Plug

CMMP-AS-...	Design on the device / coding		Counterplug / coding	
...-C2-3A-M0	PHOENIX Contact	Pin 9 (GND24V)	PHOENIX Contact	Pin 1 (L)
...-C5-3A-M0	MSTBA 2.5/9-G-5.08-BK		MSTB 2.5/9-ST-5.08-BK	
...-C5-11A-P3-M0	PHOENIX Power-COMBICON	–	PHOENIX Power-COMBICON	–
...-C10-11A-P3-M0	PC 5/11-G-7.62-BK		PC 5/11-ST-7.62-BK	

Tab. 4.16 Plug design [X9]

### 4.8.2 Pin assignment [X9] – single-phase

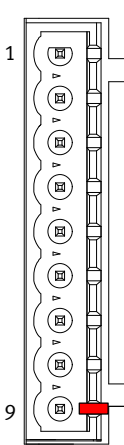
[X9]1)	Pin no.	Designation	Value	Specification
	1	L	100 ... 230 V AC	Mains phase
	2	N	±10% 50 ... 60 Hz	Mains neutral conductor (reference potential)
	3	ZK+	60 ... 380 V DC	Alternative supply: Positive intermediate circuit voltage
	4	ZK-	GND_ZK	Alternative supply: Negative intermediate circuit voltage
	5	BR-INT	< 460 V DC	Internal braking resistor connection (bridge after BR-CH when using the internal resistor).
	6	BR-CH	< 460 V DC	Brake chopper connection for – internal braking resistor toward BR-INT – or – – external braking resistor against ZK+
	7	PE	PE	Connection for protective conductor from the mains
	8	+24 V	+24 V DC ±20%	Supply for control section, holding brake and I/O
	9	GND24 V	GND24 V DC	Reference potential for supply 0V

1) Representation of the contact strip on the motor controller CMMP-AS-...-3A-M0

Tab. 4.17 Pin assignment [X9] – single-phase

## 4.8.3 Pin assignment [X9] – triple-phase

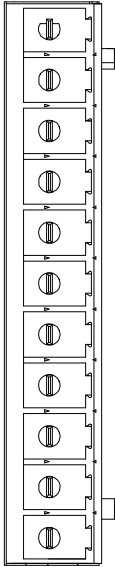
[X9]1)	Pin no.	Designation	Value	Specification
	1	L1	230 ... 480 V AC	Mains phase 1
	2	L2	±10%	Mains phase 2
	3	L3	50 ... 60 Hz	Mains phase 3
	4	ZK+	60 ... 700 V DC	Alternative supply: Positive intermediate circuit voltage
	5	ZK-	GND_ZK	Alternative supply: Negative intermediate circuit voltage
	6	BR-EXT	< 800 V DC	Connection of the external braking resistor
	7	BR-CH	< 800 V DC	Brake chopper connection for – internal braking resistor against BR-INT – or – – external braking resistor against BR-EXT
	8	BR-INT	< 800 V DC	Internal braking resistor connection (bridge after BR-CH with use of the internal resistor)
	9	PE	PE	Connection for protective conductor from the mains
	10	+24V	+24 V DC ±20 %	Supply for control section, holding brake and I/O
	11	GND24 V	GND24 V DC	Reference potential for supply

1) Representation of the contact strip on the motor controller CMMP-AS-...-11A-P3-M0

Tab. 4.18 Pin assignment [X9] – triple-phase



**Note**

The DC power supply must be generated from a max. 230/400 V or a max. 277/480 V grid.



#### 4.8.4 Mains fuse

In the mains power supply cable, an automatic circuit breaker 1) is installed for protection of the line:

Motor controller	Phases	Mains fuse
CMMP-AS-C2-3A-M0	1	B10
CMMP-AS-C5-3A-M0	1	B16
CMMP-AS-C5-11A-P3-M0	3	B16
CMMP-AS-C10-11A-P3-M0	3	B16

1) The required fuse is dependent, among other things, on the cable cross section, ambient temperature and laying procedure. Observe the following instructions!

Tab. 4.19 Required mains fuses



In designing the fuses, also observe the following standards:

- EN 60204-1 “Safety of machinery – Electrical equipment of machines – Part 1: General requirements”
- Take into consideration the legal regulations applicable for the destination as well as:
  - Regulations and standards,
  - Regulations of the testing organisations and insurers,
  - national specifications.

#### 4.8.5 AC supply

##### Switch-on behaviour:

- As soon as the motor controller CMMP-AS-...-M0 is provided with mains voltage, the intermediate circuit is charged (< 1 s) via the braking resistors, with the intermediate circuit relay deactivated.
- After the intermediate circuit has been pre-charged, the relay engages and the intermediate circuit without resistors is connected directly to the mains supply.

##### AC supply with active PFC

The PFC step is available only for 1-phase motor controllers (CMMP-AS-...-3A-M0).



##### Note

Operation with mains line choke is not permissible, since the control circuit could be stimulated to oscillate.



##### Note

Operation with isolating transformer is not permissible as no reference potential (N) is available.

**Note**

When the load voltage is switched on, ensure that the reference potential (N) is switched before the phase (L1). This can be achieved through:

- unswitched reference potential (N)
- use of fuses with leading N when switching of the reference potential is specified.

**DC supply - intermediate circuit coupling**

A direct DC power supply can be used for the intermediate circuit as an alternative to AC power or for achieving intermediate circuit coupling.

The intermediate circuits of several identically constructed motor controllers (CMMP-AS-...-3A-M0/-M3 or CMMP-AS-...-11A-P3-M0/-M3) can be connected via the terminals ZK+ and ZK- at plug connector [X9]. Coupling of the intermediate circuits is useful in applications where high braking energies occur or where motion must still be performed when the power supply fails.

**Note**

For 1-phase motor controllers (CMMP-AS-...-3A-M0), the PFC step must be deactivated when the motor controller is coupled through the intermediate circuit.

**Note**

If the intermediate circuits are coupled, it is imperative that all of the motor controllers are supplied via the same phase (e.g. L1) → Example Fig. 4.6.

Otherwise, the motor controllers will be damaged due to the resulting voltage at the rectifiers.

The maximum number of coupled motor controllers is limited by the power of the supply. Pay attention to a symmetrical load of the network here.

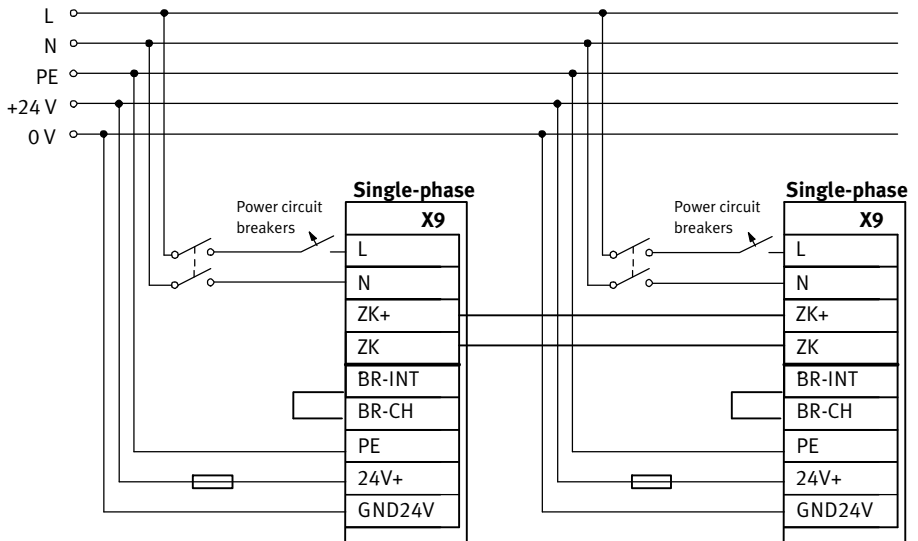

Fig. 4.6 Example of intermediate circuit coupling with common supply, single-phase



Fig. 4.6 is a schematic representation; note the information for mains fuses in → Section 4.8.4.

#### 4.8.6 Braking resistor



If no external braking resistor is used, a bridge to the internal braking resistor must be connected in order for the intermediate circuit quick discharge to function! → Tab. 4.17 or Tab. 4.18.



For larger braking power an external braking resistor must be connected [X9] → Section 4.7.2 and Fig. 4.5.

The motor controller detects the external brake resistance automatically as soon as the intermediate circuit voltage rises above the response threshold (→ A.1, Tab. A.6).

After that, a connected external brake resistance can also be displayed in the configuration software.

## 4.9 Connection: Incremental encoder input [X10]

### 4.9.1 Plug [X10]

Motor controller	Design on the device	Counterplug
CMMP-AS-...-M0	Sub-D plug connector, 9-pin, socket	Sub-D plug connector, 9-pin, pins

Tab. 4.20 Plug design [X10]

### 4.9.2 Pin assignment [X10]

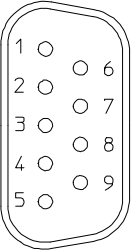
[X10]	Pin no.	Designation	Value	Specification
	1	A/CLK/CW	5 V $R_I \approx 120 \Omega$	Incremental encoder signal A Stepper motor signal CLK Pulses clockwise CW pos. polarity in accordance with RS422
	6	A#/CLK#/CW#	5 V $R_I \approx 120 \Omega$	Incremental encoder signal A Step motor signal CLK Pulses clockwise CW neg. polarity in accordance with RS422
	2	B/DIR/CCW	5 V $R_I \approx 120 \Omega$	Incremental encoder signal B Step motor signal DIR Pulses counterclockwise CCW pos. polarity in accordance with RS422
	7	B#/DIR#/CCW#	5 V $R_I \approx 120 \Omega$	Incremental encoder signal B Step motor signal DIR Pulses counterclockwise CCW neg. polarity in accordance with RS422
	3	N	5 V $R_I \approx 120 \Omega$	Incremental encoder zero pulse N pos. polarity in accordance with RS422
	8	N#	5 V $R_I \approx 120 \Omega$	Incremental encoder zero pulse N neg. polarity in accordance with RS422
	4	GND	–	Reference GND for encoder
	9	GND	–	Screening for the connecting cable
	5	VCC	+5 V $\pm 5\%$ 100 mA	Auxiliary supply, maximum load 100 mA, short-circuit proof!

Tab. 4.21 Pin assignment X10: Incremental encoder input



When connecting two motor controllers in the master-slave mode via [X11] and [X10], the pins 5 (+5 V - auxiliary supply) must not be connected to each other.

### 4.9.3 Type and design of the cable [X10]

We recommend use of the encoder connection lines in which the incremental encoder signal is twisted by pairs and the individual pairs are screened.

### 4.9.4 Connection instructions [X10]

Input [X10] can be used for processing incremental encoder signals and also for pulse direction signals as generated by stepper motor controller cards.

The input amplifier at the signal input is designed for processing differential signals as per the RS422 interface standard.

## 4.10 Connection: Incremental encoder output [X11]

### 4.10.1 Plug [X11]

Motor controller	Design on the device	Counterplug
CMMP-AS...-M0	Sub-D plug connector, 9-pin, socket	Sub-D plug connector, 9-pin, pins

Tab. 4.22 Plug design [X11]

### 4.10.2 Pin assignment [X11]

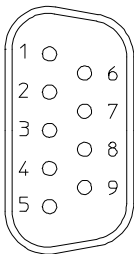
[X11]	Pin no.	Designation	Value	Specification
	1	A	5 V RA $\approx$ 66 $\Omega$ 1)	Incremental encoder signal A
	6	A#	5 V RA $\approx$ 66 $\Omega$ 1)	Incremental encoder signal A#
	2	B	5 V RA $\approx$ 66 $\Omega$ 1)	Incremental encoder signal B
	7	B#	5 V RA $\approx$ 66 $\Omega$ 1)	Incremental encoder signal B#
	3	N	5 V RA $\approx$ 66 $\Omega$ 1)	Incremental encoder zero pulse N
	8	N#	5 V RA $\approx$ 66 $\Omega$ 1)	Incremental encoder zero pulse N#
	4	GND	-	Reference GND for encoder
	9	GND	-	Screening for connecting cable
	5	VCC	+5 V $\pm$ 5% 100 mA	Auxiliary supply, maximum load 100 mA, short-circuit proof!

1) The specification for RA designates the differential output resistance

Tab. 4.23 Pin assignment [X11]: Incremental encoder output

The output driver at the signal output provides differential signals (5 V) as per the RS422 interface standard. Up to 32 other controllers can be addressed by one device.



When connecting two motor controllers in the master-slave mode via [X11] and [X10], the pins 5 (+5 V - auxiliary supply) must not be connected to each other.

## 4.11 FCT interfaces

### 4.11.1 Overview of interfaces

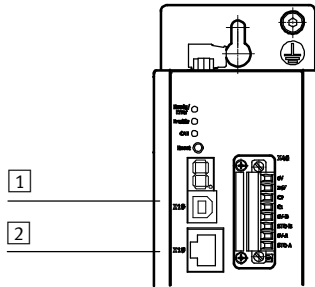

1 [X19]: USB

2 [X18]: Ethernet

Fig. 4.7 FCT interfaces

#### 4.11.2 USB [X19]

The equipment of the series CMMP-AS-...-M0 have a USB interface for parametrisation. The USB interface is used as a configuration interface for the FCT configuration.

The following functions are supported:

- Complete parametrisation of the CMMP-AS-...-M0 via FCT
- Firmware download via FCT

#### Interface design

The plug connector is designed as a Type B terminal socket. All standard terminal cables up to a length of 5m can be used. If longer cables are required, the corresponding USB repeaters must be used.

The USB interface is designed as a pure slave interface (the CMMP-AS...-M0 is the slave, the PC is the host). It meets the USB specification Rev. USB 1.1.

#### USB driver for the PC

The USB driver package is a component of the FCT installation.

The following operating systems are supported through this:

- Windows XP from Service Pack 2
- Windows Vista
- Windows 7

### 4.11.3 Ethernet TCP/IP [X18]

The equipment of the series CMMP-AS-...-M0 have a USB interface for parametrisation.

The following functions are supported:

- Point-to-point communication between PC and motor controller for parametrisation
- Complete parametrisation of the CMMP-AS-...-M0 via FCT
- Communication from one PC or one PLC to several CMMP-AS-...-M0 that are located in the same local network for the purpose of monitoring, adaptation of the parametrisation or also process control of the controller via Modbus TCP.



#### Note

Unauthorised access to the device can cause damage or malfunctions.

When connecting the device to a network:

- Protect the network from unauthorised access.

Measures for protecting the network include:

- Firewall
- Intrusion Prevention System (IPS)
- Network segmentation
- Virtual LAN (VLAN)
- Virtual private network (VPN)
- Security at physical access level (Port Security).

For further information → Guidelines and standards for security in information technology, e.g. IEC 62443, ISO/IEC 27001.

### Interface design

The interface in the device is designed as an 8P8C socket (RJ45).

The connection has two LEDs with the following function:

- Yellow                      Physical Link Detect (network connection available)
- Green                      Data Connection (data connection / data exchange)

The interface is designed to conform to the IEEE 802.3u specification. Cables of type FTP5 or high-order must be used with 100Base-TX. The interface supports the autosensing function for automatic identification of the connected cable. Both standard patch cables (1:1) and Crosslink (crossed) cables can be used.

### Supported services

The following services are supported by the Ethernet interface:

- TCP/IP
- UDP/IP
- DNS (ARP and BOOTP)
- DHCP
- AutoIP
- TFTP



TFTP must be activated separately in Windows if necessary and a pass rule defined in the Firewall.

### **Address allocation**

The network settings (IP address, subnetwork mask, gateway) can either be automatically obtained or manually specified:

- Automatically via DHCP (the automatically obtained IP address lies in the IP range specified by the DHCP server)
- Automatically via Auto IP (if no DHCP server was found, an address between 169.254.1.0 and 169.254.254.255 is selected pseudorandomly)
- Manual IP assignment (manual setting of the network parameters via FCT)

The following sequence applies for connection set-up:

1. DHCP
2. AutoIP
3. Static IP address

If no IP address can be obtained via the higher-level service, the following service is used. Thus if no address can be obtained via DHCP, first an AutoIP and then a static address is used.



## 4.12 Connection: I/O interface for STO [X40]

### 4.12.1 Plug [X40]

Motor controller	Design on the device	Counterplug
CMMP-AS-...-M0	PHOENIX MINICOMBICON MC 1.5/8-GF-3.81 BK	PHOENIX MINICOMBICON MC 1.5/8-STF-3.81 BK

Tab. 4.24 Plug design [X40]

### 4.12.2 Pin assignment [X40]

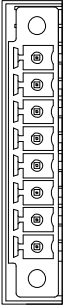
[X40]1)	Pin no.	Designation	Value	Specification
	8	0V	0V	Reference potential for auxiliary power supply.
	7	24 V	+24 V DC	Output for auxiliary power supply (24 V DC logic supply of the motor controller brought out).
	6	C2	–	Feedback contact for the status “STO” on an external controller.
	5	C1		
	4	0V-B	0V	Reference potential for STO-B.
	3	STO-B	0V / 24V	Control port B for the function STO.
	2	0V-A	0V	Reference potential for STO-A.
	1	STO-A	0V / 24V	Control port A for the function STO.

1) Representation of the plug on the device of the motor controller CMMP-AS-...-M0

Tab. 4.25 Pin assignment [X40]: I/O interface for STO

### 4.12.3 Circuitry with use of the STO safety function [X40]



To work safely with the safety function STO – “Safe Torque Off”, please observe the information in the documentation → GDCP-CMMP-AS-M0-S1-... .

### 4.12.4 Circuitry without use of the STO safety function [X40]



If you do not need the integrated safety function STO in your application, to operate the motor controller you must connect the X40 interface, as depicted in Fig. 4.8.

#### **This deactivates the integrated safety function!**

When using this circuitry for the CMMP-AS-...-M0, safety in the application must be ensured through other appropriate measures.



**Note**  
**Loss of the safety function!**  
 Lack of the safety function can result in serious, irreversible injuries, e.g. due to uncontrolled movements of the connected actuator technology.  
 Bypassing of safety equipment is impermissible.



Make sure that no jumpers or the like can be used parallel to safety wiring, e.g. through use of maximum wire cross sections or appropriate wire end sleeves with insulating collars.  
 Use twin wire end sleeves for looping through lines between neighbouring equipment.

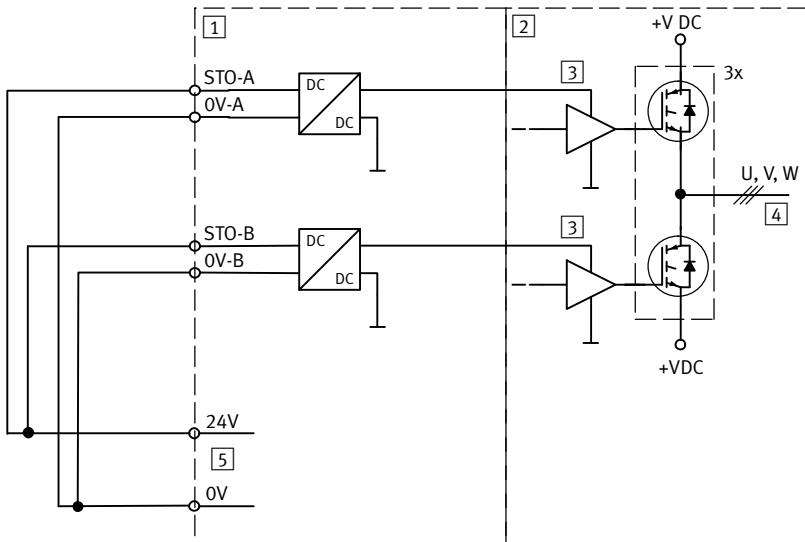

- |   |  |   |                  |
|---|--|---|------------------|
| 1 | Integrated safety function STO                                 | 3 | Driver supply    |
| 2 | Power output stage in CMMP-AS-...-M0<br>(only one phase shown) | 4 | Motor connection |
| 5 | Voltage supply   |   |                  |

Fig. 4.8 Circuitry without use of the safety function – functional principle

## 4.13 Instructions on safe and EMC-compliant installation

### 4.13.1 Explanations and terms

Electromagnetic compatibility (EMC) or electromagnetic interference (EMI) involves the following requirements:

#### Resistance to interference

Sufficient interference immunity of an electrical system or electrical device against external electrical, magnetic or electromagnetic noise via lines or space.

#### Emitted interference

Sufficiently low emitted interference of electrical, magnetic or electromagnetic interference of an electrical system or an electrical device on other devices in the environment via cables and space.



#### Warning

All PE protective earth conductors must always be connected prior to commissioning for reasons of safety.

The mains-side PE connection is made to the PE connection points (device rear wall) and [X9] of the CMMP-AS-...-M0.

Make sure that the earth connections between devices and the mounting plate are of sufficiently large dimensions in order to be able to discharge HF interference.

### 4.13.2 General remarks on EMC

Interference emission and resistance to interference of a motor controller always depend on the complete design of the drive, which consists of the following components:

- Voltage supply
- Motor controller
- Motor
- Electromechanical components
- Design and type of wiring
- Connection to the higher-order controller

#### Mains filter

Motor controllers and mains filters are provided to increase the interference immunity and to reduce the level of emitted interference.

Motor controller	Mains filter
CMMP-AS-C2-3A-M0	In order to increase the interference immunity and decrease the level of emitted interference, the motor controller already has integrated motor chokes and mains filters, which means that it can be operated without additional shielding and filters in most applications.
CMMP-AS-C5-3A-M0	
CMMP-AS-C5-11A-P3-M0	
CMMP-AS-C10-11A-P3-M0	

Tab. 4.26 Mains filter



The motor controllers CMMP-AS-...-M0 have been checked in accordance with EMC product standard EN 61800-3 that is applicable to electric drives. The standard components from the Festo accessories were used for qualification. EMC can only be guaranteed if the motor and encoder or resolver cables from Festo are used and not extended or changed in any other form.

In the majority of cases, no external filter measures are required (➔ Section 4.13.3, Tab. 4.27).

The declaration of conformity is available at ➔ [www.festo.com](http://www.festo.com).

### 4.13.3 EMC areas: First and second environment

If installed correctly and if all connecting cables are wired correctly, the CMMP-AS-...-M0 motor controllers fulfil the specifications of the related product standard EN 61800-3. This standard no longer refers to limit value classes, but to so-called environments.



**Note**

The first environment (C2) includes electricity grids connected to residential housing; the second environment (C3) includes grids connected only to industrial plants.



The device may generate high frequency interference, which may make it necessary to implement interference suppression measures in residential areas.

Applicable for the motor controller CMMP-AS-...-M0:

EMC class	Area	Compliance with EMC requirements
Emitted interference	Second environment (industrial)	Motor cable lengths up to 25 m without external filters. A suitable mains filter must be installed when longer motor cables of 25 ... 50 m are used.
Resistance to interference	Second environment (industrial)	Independent of the motor cable length.

Tab. 4.27 EMC requirements

#### 4.13.4 EMC-compliant wiring

The following must be observed for EMC-compliant design of the drive system (see also chapter 4.2 → Page 25):

<b>Cable interfaces on the CMMP-AS-...-M0</b>			
Port	Interface	Cable length [m]	Comment
X1	I/O communication	≤ 5	Recommendation: Screened
X2A	Resolver	≤ 50	screened
X2B	Encoder	≤ 50	screened
X4	CAN	≤ 40	at 1 Mbit/s (line length dependent on the bit rate)
X6	Motor	≤ 25	screened (→ Tab. 4.27)
X9	Power supply	≤ 2	–
X10	Increment generator input	≤ 30	screened
X11	Increment generator output	≤ 5	screened
X18	Ethernet	≤ 10	at least CAT-5
X19	USB	≤ 5	in accordance with USB specification Rev. USB 1.1
X40	Safety function STO	≤ 30	–

Tab. 4.28 Permissible cable lengths on the CMMP-AS-...-M0

- To keep leaked current and losses in the motor cable as low as possible, the motor controller CMMP-AS-...-M0 should be placed as close to the motor as possible (→ Chapter 4.13.5 → Page 55).
- Motor and encoder cable must be screened.
- The screening of the motor cable is attached to the housing of the motor controller CMMP-AS-...-M0 (screened connection terminals, spring clips). The cable screening is also always attached to the corresponding motor controller to prevent leaked current flowing back to the controller which caused it.
- The mains-side PE connection is connected to the PE connection point of the power supply [X9] and to the PE connection of the housing.
- The PE internal conductor of the motor cable is connected to the PE connection point of the motor connection [X6].
- Signal lines must be separated as far as possible from the power cables. They should not be routed parallel to one another. If crossovers are unavoidable, they should be made as close to vertical (i.e. at a 90° angle) as possible.
- For unscreened signal and control lines, safe/reliable operation cannot be guaranteed. If they must be used, they should at least be twisted.
- Even screened cables always have short unscreened parts at both ends (unless a screened plug housing is used).

In general:

- Connect the inner screenings to the pins of the plug connectors provided for the purpose; length maximum 40 mm.
- Length of the unscreened wires with self-made cables, maximum 35 mm.
- Connect entire screening on the controller side flush to the PE terminal; maximum length 40 mm.

- Connect entire screening flush at the motor to the plug or motor housing; length maximum 40 mm (guaranteed with NEBM-...).



**Danger**

All PE protective earth conductors must always be connected prior to commissioning for reasons of safety.

The regulations of EN 50178 and EN 60204-1 for protective grounding must always be observed during installation!

#### 4.13.5 Operation with long motor cables

For applications in combination with long motor cables and/or if the wrong motor cables are selected with excessive cable capacity, the filters may be subjected to thermal overload. To avoid this, it is necessary to enter the cable length used in the application in the FCT parametrisation software. By using this information the FCT plug-in then automatically calculates the optimal cycle time for the current regulator and PWM control. The following restrictions are taken into consideration:

Cable length	Restrictions in the FCT plug-in CMMP
≤ 15 m	<ul style="list-style-type: none"> <li>– The minimum value for “cycle time current regulator” is 62.5 μs.1)</li> <li>– The option “half output stage frequency” is set and can be edited.2)</li> </ul>
> 15 m, ≤ 25 m	<ul style="list-style-type: none"> <li>– The minimum value for “cycle time current regulator” is 62.5 μs.1)</li> <li>– The option “half output stage frequency” is set and cannot be edited.</li> </ul>
> 25 m	<ul style="list-style-type: none"> <li>– The minimum value for “cycle time current regulator” is 125 μs and cannot be edited.</li> <li>– The option “half output stage frequency” is set and cannot be edited.</li> </ul>

1) The actual value is automatically determined by the FCT based on the motor controller axis combination.

2) The ability to edit the option “half output stage frequency” does not apply to three-phase controllers.

Tab. 4.29 Restrictions in the FCT plug-in depending on the cable length

In addition, the following procedure is strongly recommended for applications in which long motor cables are required:

- From a cable length of > 25 m, use only cables with a capacitance between the motor phase and screening of < 200 pF/m, or better, < 150 pF/m and also use a mains filter!



#### Note

Longer cable lengths result in deviations to the current regulator amplification (line resistance).

#### 4.13.6 ESD protection



#### Caution

Unused Sub-D plug connectors present a danger of damage to the device or to other parts of the system as a result of ESD (electrostatic discharge).

In the design of the motor controller CMMP-AS-...-M0, great importance has been placed on high resistance to interference. For this reason, individual function blocks are galvanically separated from each other. Signal transmission within the device is performed via an optocoupler.

A distinction is made between the following separated areas:

- Output stage with intermediate circuit and mains input
- Control electronics with analogue signal processing
- 24 V supply and digital inputs and outputs

## 5 Commissioning

### 5.1 General connection instructions



As the installation of the connecting cables is critical for EMC, the preceding chapter 4.13.4 → Page 53 must be observed!



Observe the instructions on commissioning the safety function STO – “Safe Torque Off” in the documentation → GDCP-CMMP-AS-M0-S1-... .



#### **Warning**

Non-compliance with the safety instructions in chapter 1 → Page 9 can result in material damage, injury, electric shock, or in extreme cases, fatality.

### 5.2 Tools / material

- Slotted head screwdriver size 1
- USB or EtherNet cable for parameterisation
- Encoder cable
- Motor cable
- Power supply cable
- Control cable

### 5.3 Connecting the motor

1. Connect motor cable on the motor side.
2. Insert the PHOENIX plug into the socket [X6] on the device.
3. Clamp the cable shields to the shield terminals (not suitable as strain-relief).
4. Connect encoder cable on the motor side.
5. Insert the Sub-D plug connector into socket [X2A] resolver or [X2B] encoder of the device and tighten the locking screws.
6. Check all plug connectors once again.



## 5.4 Connect motor controller CMMP-AS-...-M0 to the power supply



### Warning

Danger of electric shock.

- When cables are not mounted to the plugs [X6] and [X9].
- When connecting cables are disconnected when powered.

Touching live parts causes severe injuries and can lead to death.

The product may only be operated in a built-in status and when all protective measures have been initiated.

Before touching live parts during maintenance, repair and cleaning work and when there have been long service interruptions:

1. Switch off power to the electrical equipment via the mains switch and secure it against being switched on again.
2. After switch-off, wait at least 5 minutes discharge time and check that power is turned off before accessing the controller.

1. Make sure that the power supply is switched off.
2. Connect the PE cable of the mains supply to the PE earth socket.
3. Insert the PHOENIX plug into the socket [X9] of the motor controller.
4. Connect 24 V connections with appropriate power pack.
5. Make the network power supply connections.
6. Check all plug connectors once again.

## 5.5 Connecting a PC

1. Connect PC via USB → 4.11.2 USB [X19] or Ethernet → 4.11.3 Ethernet TCP/IP [X18] to the motor controller.

## 5.6 Check operating status

1. Make sure that the controller enable is switched off (controller enable: DIN 5 at [X1]).
2. Switch on the power supplies of all equipment.

During the boot process, the point of the 7-segment display lights up.

After completion of the boot process, the READY-LED lights up green.



If the READY LED lights up red, there is a malfunction. If an “E” appears in the 7-segment display followed by a sequence of numbers, this is an error message and you must rectify the cause of the error. In this case, continue to read in the chapter A → Page 65.

If no indicator lights up on the device, execute the following steps:

1. Switch off the power supply.
2. Wait 5 minutes to allow the intermediate circuit to discharge.
3. Check all connecting cables.
4. Check that the 24 V power supply is functional.
5. Switch on the power supply again.
6. If still no indicator lights up → Device is defective.

## 6 Service functions and diagnostic messages

### 6.1 Protective and service functions

#### 6.1.1 Overview

The motor controller CMMP-AS-...-M0 has a complex array of sensors that monitor the controller section, power output stage, motor and external communication to ensure that they function excellently. All diagnostic events which occur are saved in the internal diagnostic memory. Most errors cause the controller section to switch off the motor controller and the power output stage. The motor controller cannot be switched back on until the error is remedied and then acknowledged.

A complex system of sensors and numerous monitoring functions ensure operational reliability:

- Measurement of the motor temperature
- Measurement of the power output stage temperature
- Earth fault detection (PE)
- Detection of short-circuits between two motor phases
- Detection of overvoltages in the intermediate circuit
- Detection of faults in the internal voltage supply
- Collapse of supply voltage
- Detection of faults in conjunction with the functional safety engineering ([X40])

#### 6.1.2 Phases and mains failure detection

The motor controllers CMMP-AS-...-11A-P3-M0 detect a phase failure in three-phase operation (phase failure detection) or failure of several phases (network failure detection) of the mains supply at the device.

#### 6.1.3 Overload current and short-circuit monitoring

Overload current and short-circuit monitoring detects short circuits between two motor phases and short circuits at the motor output terminals against the positive and negative reference potential of the intermediate circuit and against PE. If the error control detects overload current, the power output stage shuts down immediately, guaranteeing protection against short circuits.

#### 6.1.4 Overvoltage monitoring for the intermediate circuit

The overvoltage monitoring for the intermediate circuit takes effect as soon as the intermediate circuit voltage exceeds the operating voltage range. The power output stage is then deactivated.

#### 6.1.5 Temperature monitoring for the heat sink

The heat sink temperature of the output end stage is measured with a linear temperature sensor. The temperature limit varies between the device performance classes → Tab. A.3 on page 66.

A temperature warning is triggered approx. 5 °C below the limit value.

### 6.1.6 Monitoring of the motor

The motor controller CMMP-AS-...-M0 has the following protective functions for monitoring the motor and the connected shaft encoder:

Protective function	Description
Monitoring the shaft encoder	An error of the shaft encoder results in switching off of the power output stage. For the resolver, for example, the tracking signal is monitored. For incremental encoders, the commutation signals are checked. Generally true for intelligent encoders is that their various error messages are evaluated and reported to the CMMP-AS-...-M0 as common error E 08-8.
Measurement and monitoring of the motor temperature	The motor controller CMMP-AS-...-M0 has a digital and an analogue input for recording and monitoring the motor temperature. They are selectable as temperature sensors. <ul style="list-style-type: none"> <li>– [X6]: Digital input for PTCs, N/C contacts and N/O contacts.</li> <li>– [X2A] and [X2B]: N/C contact and KTY series analogue sensors. Other sensors (NTC, PTC) require a corresponding software adaptation as needed.</li> </ul>

Tab. 6.1 Protective functions of the motor

### 6.1.7 I<sup>2</sup>t monitoring

The motor controller CMMP-AS-...-M0 has I<sup>2</sup>t monitoring to limit the average power loss in the power end stage and in the motor. Since the power loss that occurs in the power electronics and the motor can, in the worst case, grow at a rate equal to the square of the flowing current, the squared current value is taken as a measure for the power loss.

### 6.1.8 Power monitoring for the brake chopper

The braking resistors are monitored on the firmware side through the function I<sup>2</sup>t brake chopper. When the power monitoring “I<sup>2</sup>t brake chopper” of 100% is reached, the output of the internal braking resistor is limited to the rated output.



#### Note

As a result of this switch-back, the error “E 07-0” “Overvoltage in the intermediate circuit” is generated. If the braking process is not completed, the residual energy is fed back to the motor controller and results in an uncontrolled running out of the drive if no automatic locking mechanical system, clamping units or weight compensation is used. This can result in damage to the machine. Connection of an appropriate clamping unit to prevent an uncontrolled running out of the drive at the motor controller is recommended.

In addition, the brake chopper is protected by means of overcurrent detection. If a short circuit is detected via the braking resistor, the brake chopper controller is switched off.

### 6.1.9 Commissioning status

Motor controllers sent to Festo for servicing are loaded with other firmware and parameters for testing purposes.

Before it is commissioned again at the location of the final customer, the motor controller CMMP-AS-...-M0 must be parametrised. The parametrisation software queries the commissioning status and prompts the user to parameterise the motor controller. In parallel, the device signals through the visual indicator 'A' on the 7-segment display that, although it is ready for operation, it has not been parametrised yet.

### 6.1.10 Rapid discharge of the intermediate circuit

When a mains supply failure is detected, the intermediate circuit is quickly discharged within the safety time specified in EN 60204-1.

Delayed connection of the brake chopper by power class in parallel operation and when a mains failure occurs ensures that the main energy during rapid discharge of the intermediate circuit is taken over through the braking resistors of the higher power classes.



But the rapid discharge can be ineffective in certain device constellations, especially when several motor controllers are connected in parallel in the intermediate circuit or a brake resistance is not connected. The motor controllers may carry dangerous voltage for up to 5 minutes after being switched off (capacitor residual charge).

### 6.1.11 Detection of faults in conjunction with the functional safety engineering

- Discrepancy time monitoring STO
- Driver supply monitoring

## 6.2 Operating mode and diagnostic messages

### 6.2.1 Operation and display components

The motor controller CMMP-AS-...-M0 has three LEDs on the front and one 7-segment display for showing the operating statuses.

Element	LED colour	Function
7-segment display	–	Displays the operating mode and a coded error number should an error occur → Section 6.2.2
LED1	Green	Operating status
	Red	Error
LED2	Green	Controller enable
LED3	Yellow	CAN bus status display
RESET button	–	Hardware reset for the processor

Tab. 6.2 Display components and RESET pushbutton

### 6.2.2 7-segment display

The display and the meaning of the symbols shown are illustrated in the following table:

Display <sup>1)</sup>	Meaning	
A	The motor controller must still be parameterised.	
F	Signals that firmware is currently being loaded into the flash.	
. (flashes)	Bootloader active (only the point flashes).	
d	Signals that a parameter set is currently being loaded from the SD card to the controller.	
H (flashes)	“H”: The motor controller is in the “safe status”. This does not have the same meaning as the information on the status of the safety function STO (Safe Torque Off).	
H E L L O	Display for the function “Identify Controller”.	
(rotating)	The outer segments are displayed “rotating” in the speed adjustment operating mode. The display depends on the actual position or speed. The middle bar is only active when controller enable is active.	
I	Controlled torque operation.	
P x x x	000	No positioning active.
	001...255	Positioning record 001 ... 255 active.
	259/260	Jog positive/negative.
	262	CAM-IN / CAM-OUT (cam disc).
	264/265	Direct records for manual travel via FCT or FHPP direct operation.
	P H x	0
1		Phase “Crawl”.
2		Phase “Approach zero point”.
E x x y	Error message with main index “xx” and sub-index “y”.	
- x x y	Warning message with main index “xx” and sub-index “y”. A warning is shown at least twice on the 7-segments display.	

1) Several characters are displayed one after the other.

Tab. 6.3 Operating mode and error display

### 6.2.3 Acknowledgement of error messages

Error messages can be acknowledged through:

- the parametrisation interface
- the fieldbus (control word)
- a decreasing edge at DIN5 [X1]

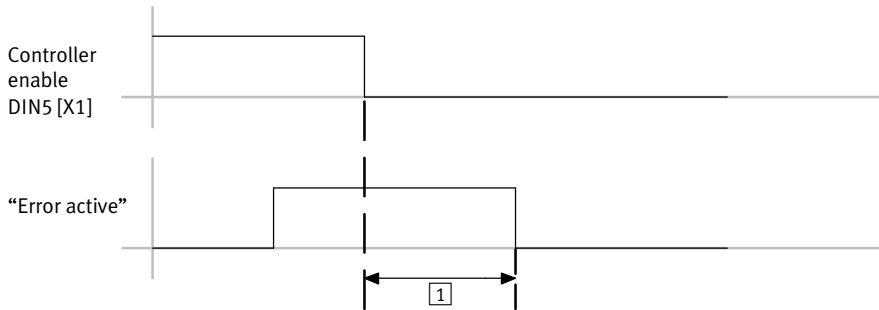

1 ≈ 80 ms

Fig. 6.1 Timing diagram: Acknowledge error



Diagnostic events that are parameterised as warnings are automatically acknowledged when the cause is no longer present.

### 6.2.4 Diagnostic messages

The significance and their measures for diagnostic messages are summarised in the following chapter:

→ Chapter A Technical appendix

## 7 Maintenance, care, repair and replacement

### 7.1 Maintenance and care



#### **Warning**

#### **Danger of electric shock.**

Touching live parts causes severe injuries and can lead to death. Do not disconnect connecting cables when powered.

Before touching live parts during maintenance, repair and cleaning work and when there have been long service interruptions:

1. Switch off power to the electrical equipment via the mains switch and secure it against being switched on again.
2. After switch-off, wait at least 5 minutes discharge time and check that power is turned off before accessing the controller.

If used as intended, the product is maintenance-free.

- Clean the outside of the product with a soft cloth.

### 7.2 Repair



Repair or maintenance of the product is not permissible. If necessary, replace the complete product.

### 7.3 Replacement and disposal

#### 7.3.1 Dismounting and installation



When dismantling, please observe the safety instructions in section 7.1

Information regarding installation can be found here:

- Mounting → Section 3.2.
- Electrical installation → Chapter 4.
- Commissioning → Chapter 5.

#### 7.3.2 Disposal



Observe the local regulations for environmentally appropriate disposal of electronic modules. The product is RoHS-compliant.



## A Technical appendix

### A.1 Technical data CMMP-AS-...-M0

General technical data				
CMMP-AS-	C2-3A-M0	C5-3A-M0	C5-11A-P3-M0	C10-11A-P3-M0
Type of mounting	Screwed onto connecting plate			
Display	7-segment display			
Parameterisation interface	USB 1.1			
	EtherCat TCP/IP			
Approvals				
CE marking (see declaration of conformity)	In accordance with EU Low Voltage Directive			
	In accordance with EU EMC Directive			
	In accordance with EU Machinery Directive			
Dimensions and weight				
Dimensions [mm] (HxWxD) <sup>1)</sup>	202x66x207	227x66x207	252x79x247	
Mounting plate dimensions [mm]	248x61		297x75	
Weight [kg]	2.1	2.2	3.5	

1) without plugs, shield screw and screw heads

Tab. A.1 Technical data: General

Transport and storage				
CMMP-AS-	C2-3A-M0	C5-3A-M0	C5-11A-P3-M0	C10-11A-P3-M0
Temperature range [°C]	-25 ... +70			

Tab. A.2 Technical data: Transport and storage

<b>Operating and environmental conditions</b>					
CMMP-AS-	C2-3A-M0	C5-3A-M0	C5-11A-P3-M0	C10-11A-P3-M0	
Permissible setup altitude above sea level					
with rated output	[m]	1000			
with power reduction <sup>1)</sup>	[m]	1000 ... 2000 (max.)			
Air humidity	[%]	0 ... 90 (non-condensing)			
Protection class		IP20			
Degree of contamination		2			
Operating temperature	[°C]	0 ... +40			
Operating temperature with power reduction of 2.5 % per Kelvin	[°C]	+40 ... +50			
Switch-off temperature, heat sink power section	[°C]	100	80	80	80

1) Above 1000 m above sea level Performance reduction of 1% per 100 m

Tab. A.3 Technical data: Operating and environmental conditions

<b>Electrical data logic supply</b>				
CMMP-AS-	C2-3A-M0	C5-3A-M0	C5-11A-P3-M0	C10-11A-P3-M0
Nominal voltage	[V DC]	24 ±20%		
Nominal current <sup>1)</sup>	[A]	0.55	0.65	1
Maximum current for holding brake	[A]	1		2
With higher power requirement of the holding brake → Fig. 4.5 page 38				

1) plus current consumption from an existing holding brake and I/Os

Tab. A.4 Technical data: Logic supply



**Note**

With a warm motor and a supply voltage that is too low (outside of tolerance), the motor's brakes cannot open 100%, which can lead to premature wearing of the brake.

<b>Electrical data load voltage</b>					
CMMP-AS-		C2-3A-M0	C5-3A-M0	C5-11A-P3-M0	C10-11A-P3-M0
Number of phases		1		3	
Nominal voltage	[V AC]	100 ... 230		230 ... 480	
Nominal voltage tolerance	[%]	±10		±10	
Mains frequency	[Hz]	50 ... 60			
In continuous operation, max. effective nominal current	[A]	3	6	5.5	11
Intermediate circuit voltage (without PFC)	[V DC]	310 ... 320		560 ... 570	
Intermediate circuit voltage (with PFC)	[V DC]	360 ... 380		–	
Alternative DC supply	[V DC]	60 ... 380		60 ... 700	
<b>Performance data of the PFC step with nominal supply voltage of 230 V AC ±10 %</b>					
Continuous output	[W]	500	1000	–	
Peak power	[W]	1000	2000	–	
<b>Performance data of the PFC step with minimal supply voltage of 110 V AC</b>					
Continuous output	[W]	250	500	–	
Peak power	[W]	500	1000	–	

Tab. A.5 Technical data: Load voltage

Below the nominal power supply voltage, the PFC stage power is linearly reduced. These power characteristic curves are shown in the following figure.

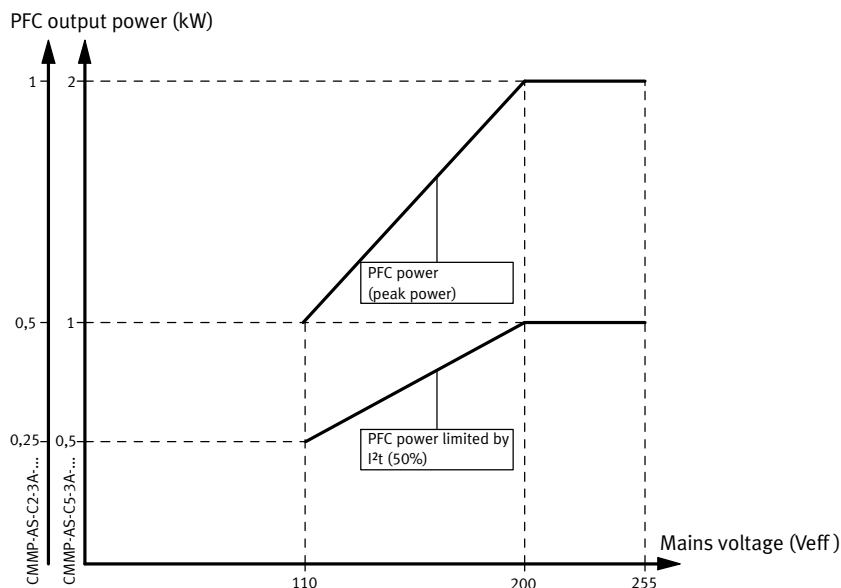

Fig. A.1 Performance characteristics curve of the PFC level

Technical data for brake resistance					
CMMP-AS-		C2-3A-M0	C5-3A-M0	C5-11A-P3-M0	C10-11A-P3-M0
Trigger level (without PFC)	[V DC]	389		760	
Trigger level (with PFC)	[V DC]	440		-	
Max. voltage (without PFC)	[V DC]	400		800	
Max. voltage (with PFC)	[V DC]	460		-	
Braking resistor, integrated					
Resistance value	[Ω]	60		68	
Pulse power	[kW]	2.8		8.5	
Continuous output	[W]	10	20	110	
Braking resistor, external					
Resistance value	[Ω]	≥ 50		≥ 40	
Operating voltage	[V]	≥ 460		≥ 800	
Continuous output	[W]	≤ 2500		≤ 5000	

Tab. A.6 Technical data for brake resistance

<b>Motor cable</b>				
CMMP-AS-	C2-3A-M0	C5-3A-M0	C5-11A-P3-M0	C10-11A-P3-M0
Max. motor cable length for second environment [m]	≤ 25 (without filter)			
Cable capacity of one phase against screening [pF/m]	≤ 200			

Tab. A.7 Technical data: Motor cable

<b>Motor temperature monitoring</b>			
Digital sensor	N/C contact:	$R_{Cold} < 500 \Omega$	$R_{Hot} > 100 \text{ k}\Omega$
Analogue sensor	Silicon temperature sensor, e.g. KTY81, 82 or similar. R25 ≈ 2000 Ω R100 ≈ 3400 Ω		

Tab. A.8 Technical data: Motor temperature monitoring

<b>Output data</b>				
CMMP-AS-	C2-3A-M0 <sup>1)</sup>	C5-3A-M0 <sup>1)</sup>	C5-11A-P3-M0 <sup>2)</sup>	C10-11A-P3-M0 <sup>2)</sup>
Voltage [V AC]	0 ... 270		0 ... 360	
Nominal power [kVA]	0.5	1	3	6
Max. Power for 5 seconds [kVA]	1	2	6	12

1) Data for operation at 1x230 V AC [±10%], 50 ... 60 Hz

2) Data for operation at 3x400 V AC [±10%], 50 ... 60 Hz

Tab. A.9 Technical data: Output data



**Note**

The following tables Tab. A.10, Tab. A.11, Tab. A.12, Tab. A.13, Tab. A.14 and Tab. A.15 describe the maximum possible output data of the motor controller. The specified options “cycle time current regulator” and “half output stage frequency” are automatically calculated in the FCT plug-in based on the parameterised motor controller/motor-axis combination. This calculation determines the best values to prevent an overloading of the components.

In addition, the length of the motor cable is also incorporated into the calculation in order to protect the mains filters contained in the motor controller → Section 4.13.5.

<b>CMMP-AS-C2-3A-M0</b>					
Cycle time current regulator <sup>1)</sup>	[μs]	62.5		125	
Half output stage frequency <sup>1)</sup>		active	inactive	active	inactive
Output stage frequency	[kHz]	8	16	4	8
Rated output current, effective	[A]	2.5	2.2	2.5	2.5
<b>Maximum output current for maximum time (effective value)</b>					
Max. output current	[A]	5	4.4	5	5
Max. time	[s]	5	5	5	5
Max. output current	[A]	7.5	6.6	7.5	7.5
Max. time	[s]	1.3	1.3	1.3	1.3
Max. output current	[A]	10	8.8	10	10
Max. time	[s]	0.5	0.5	0.5	0.5

1) Option with FCT able to be parametrised

Tab. A.10 Output data CMMP-AS-C2-3A-M0

<b>CMMP-AS-C5-3A-M0</b>					
Cycle time current regulator <sup>1)</sup>	[μs]	62.5		125	
Half output stage frequency <sup>1)</sup>		active	inactive	active	inactive
Output stage frequency	[kHz]	8	16	4	8
Rated output current, effective	[A]	5	4.4	5	5
<b>Maximum output current for maximum time (effective value)</b>					
Max. output current	[A]	10	8.8	10	10
Max. time	[s]	5	5	5	5
Max. output current	[A]	15	13.2	15	15
Max. time	[s]	1.3	1.3	1.3	1.3
Max. output current, effective	[A]	20	17.6	20	20
Max. time	[s]	0.5	0.5	0.5	0.5

1) Option with FCT able to be parametrised

Tab. A.11 Output data CMMP-AS-C5-3A-M0

<b>CMMP-AS-C5-11A-P3-M0</b>					
Cycle time current regulator <sup>1)</sup>	[μs]	62.5		125	
Half output stage frequency <sup>1)</sup>		active	inactive	active	inactive
Output stage frequency	[kHz]	8	16	4	8
Rated output current, effective	[A]	5	2.5	5	5
<b>Maximum output current for maximum time (effective value)</b>					
Max. output current	[A]	10	5	10	10
Max. time	[s]	5	5	5	5
Max. output current	[A]	15	7.5	15	15
Max. time	[s]	0.8	1.2	0.8	0.8
Max. output current	[A]	20	10	20	20
Max. time	[s]	0.1	0.15	0.1	0.1

1) Option with FCT able to be parametrised

Tab. A.12 Output data CMMP-AS-C5-11A-P3-M0 with electrical rotation frequency ≤ 5 Hz

<b>CMMP-AS-C5-11A-P3-M0</b>					
Cycle time current regulator <sup>1)</sup>	[μs]	62.5		125	
Half output stage frequency <sup>1)</sup>		active	inactive	active	inactive
Output stage frequency	[kHz]	8	16	4	8
Rated output current, effective	[A]	5	2.5	5	5
<b>Maximum output current for maximum time (effective value)</b>					
Max. output current	[A]	10	5	10	10
Max. time	[s]	5	5	5	5
Max. output current	[A]	15	7.5	15	15
Max. time	[s]	2	2	2	2
Max. output current	[A]	20	10	20	20
Max. time	[s]	0.5	0.5	0.5	0.5

1) Option with FCT able to be parametrised

Tab. A.13 Output data CMMP-AS-C5-11A-P3-M0 with electrical rotation frequency ≥ 20 Hz

<b>CMMP-AS-C10-11A-P3-M0</b>					
Cycle time current regulator <sup>1)</sup>	[μs]	62.5		125	
Half output stage frequency <sup>1)</sup>		active	inactive	active	inactive
Output stage frequency	[kHz]	8	16	4	8
Rated output current, effective	[A]	8	3.45	10	8
<b>Maximum output current for maximum time (effective value)</b>					
Max. output current	[A]	16	6.9	20	16
Max. time	[s]	5	5	5	5
Max. output current	[A]	24	10.35	30	24
Max. time	[s]	0.1	0.2	0.1	0.1
Max. output current	[A]	32	13.8	40	32
Max. time	[s]	0.07	0.15	0.07	0.07

1) Option with FCT able to be parametrised

Tab. A.14 Output data CMMP-AS-C10-11A-P3-M0 with electrical rotation frequency ≤ 5 Hz

<b>CMMP-AS-C10-11A-P3-M0</b>					
Cycle time current regulator <sup>1)</sup>	[μs]	62.5		125	
Half output stage frequency <sup>1)</sup>		active	inactive	active	inactive
Output stage frequency	[kHz]	8	16	4	8
Rated output current, effective	[A]	8	3.45	10	8
<b>Maximum output current for maximum time (effective value)</b>					
Max. output current	[A]	16	6.9	20	16
Max. time	[s]	5	5	5	5
Max. output current	[A]	24	10.35	30	24
Max. time	[s]	2	2	2	2
Max. output current	[A]	32	13.8	40	32
Max. time	[s]	0.5	0.5	0.5	0.5

1) Option with FCT able to be parametrised

Tab. A.15 Output data CMMP-AS-C10-11A-P3-M0 with electrical rotation frequency ≥ 20 Hz



### A.1.1 Interfaces

#### I/O interface [X1]

Digital I/O modules			Values	Comment
Inputs DINO ... DIN9	Input voltage	[V]	24	active high, conforming to EN 61131-2
	Voltage range	[V]	8 ... 30	
Outputs DOUT 0 ... DOUT3	Output voltage	[V]	24	active high, galvanically isolated
	Voltage range <sup>1)</sup>	[V]	8 ... 30	
+24 V	Max. output current	[mA]	100	per output
	Output voltage	[V]	24	
GND24	Max. output current	[mA]	100	–
	Voltage	[V]	0	
				Reference potential for digital I/Os

1) With use as digital input (configuration with FCT)

Tab. A.16 Technical data: Digital inputs/outputs [X1]

Analogue inputs/outputs			Values	Comment
AIN0 #AIN0	Input section	[V]	±10 differential	–
	Resolution	Bit	16	
	Time delay	[µs]	< 250	
	Max. input voltage	[V]	30	
	R <sub>i</sub>	[kΩ]	30	
AIn1	Input section	[V]	±10 Single-ended	This input can be optionally parametrised also as a digital input DIN12 with an 8 V trigger level. <sup>1)</sup>
	Resolution	Bit	10	
	Time delay	[µs]	< 250	
AIn2	Input section	[V]	±10 Single-ended	This input can be optionally parametrised also as a digital input DIN13 with an 8 V trigger level. <sup>1)</sup>
	Resolution	[Bit]	10	
	Time delay	[µs]	< 250	
AOUT0, AOUT1	Output section	[V]	±10	–
	Resolution	[Bit]	9	
	Critical frequency	[kHz]	1	
AGND	Voltage	[V]	0	Reference potential
+VREF	Output section	[V]	0 ... 10	Reference output for setpoint potentiometer

1) Configuration with FCT. Observe note → Section 4.3.3

Tab. A.17 Technical data: Analogue inputs/outputs [X1]

**Resolver connection [X2A]**

Resolver connection			Values	Meaning
S1 S3	Input voltage <sup>1)</sup>	[V]	3.5	COSINE+
	Input frequency	[kHz]	5 ... 10	COSINE-
	Internal resistance R <sub>i</sub>	[kΩ]	> 5	
S2 S4	Input voltage <sup>1)</sup>	[V]	3.5	SINE+
	Input frequency	[kHz]	5 ... 10	SINE-
	Internal resistance R <sub>i</sub>	[kΩ]	> 5	
R1	Voltage <sup>1)</sup>	[V]	7	Carrier signal
	Frequency	[kHz]	5 ... 10	
	Output current <sup>1)</sup>	[mA]	I <sub>A</sub> < 150	
R2				GND
MT+	Voltage	[V]	+ 3.3	Motor temperature sensor, N/C contact, PTC, KTY...
MT-	Internal resistance R <sub>i</sub>	[kΩ]	2	Reference potential for temperature sensor

1) Rms value

Tab. A.18 Technical data: Resolver [X2A]

Parameter	Values
Transmission ratio	0.5
Carrier frequency	[kHz] 5 ... 10
Excitation voltage <sup>1)</sup>	[V] 7, short circuit proof
Excitation impedance (at 10 kHz)	[Ω] ≥ (20 + j20)
Stator impedance	[Ω] ≤ (500 + j1000)

1) Rms value

Tab. A.19 Technical data: Resolver [X2A]

Parameter	Values
Resolution	[Bit] 16
Signal detection time delay	[μs] < 200
Speed resolution	[min <sup>-1</sup> ] approx. 4
Absolute accuracy of angle ac- quisition	['] < 5
max. speed	[min <sup>-1</sup> ] 16000

Tab. A.20 Technical data: Resolver evaluation [X2A]

**Encoder connection [X2B]**

Parameter		Value	Comment
Encoder line count	[Lines/R]	1 ... 262144	can be parameterised
Angular resolution/Interpolation	[Bit/period]	10	
Tracking signals			
A, B	[Vpp]	1	differential; 2.5 V offset
N	[Vpp]	0.2 ... 1	differential; 2.5 V offset
Commutator tracks A1, B1 (optional)	[Vpp]	1	differential; 2.5 V offset
Track signal input impedance	[Ω]	120	Differential input
Critical frequency $f_{crit}$			
High-resolution track	[kHz]	> 300	
Commutation track	[kHz]	approx. 10	
Additional communication interface		EnDat (Heidenhain), HIPERFACE (Stegmann) and BiSS	
Output supply		Current-limited, regulation via sensor cable	
Voltage	[V]	5 or 12	switchable via software
Current	[mA]	max. 300	

Tab. A.21 Technical data: Encoder connection [X2B]

**CAN bus [X4]**

Communication interface	Values
CANopen controller	ISO 11898, Full CAN controller, max. 1M baud
CANopen protocol	in accordance with CiA 301 and CiA 402

Tab. A.22 Technical data: CAN bus [X4]

**Incremental encoder input [X10]**

Feature		Value	Comment
Number of lines	[Lines/R]	1 ... 2 <sup>28</sup>	can be parameterised
Track signals A, A#,B, B#, N, N#		in accordance with RS422 specification	
Maximum input frequency	[kHz]	1000	
Pulse direction interface CLK, CLK#, DIR, DIR#, RESET, RESET#		in accordance with RS422 specification	
Output			
	Voltage [V]	5	
	Current [mA]	max. 100	

Tab. A.23 Technical data: Incremental encoder input [X10]

**Incremental encoder output [X11]**

Feature		Value	Comment
Number of output lines	[Lines/R]	1 ... 8192, 16384	
Connection level		Differential in accordance with RS422 specification	
Track signals A, B, N		in accordance with RS422 specification	N track can be switched off
Output impedance $R_{o,diff}$	[ $\Omega$ ]	66	
Critical frequency $f_{crit}$	[MHz]	> 1.8	Lines/s
Output supply			
	Voltage [V]	5	
	Current [mA]	max. 100	

Tab. A.24 Technical data: Incremental encoder output [X11]

**Electrical data [X40]**

<b>Control ports STO-A, 0V-A / STO-B, 0V-B [X40]</b>		
Nominal voltage	[V]	24 (related to 0V-A/B)
Voltage range	[V]	19.2 ... 28.8
Permissible residual ripple	[%]	2 (related to nominal voltage 24 V)
Overvoltage discharge	[V]	31 (disconnect in case of error)
Nominal current	[mA]	20 (typical; maximum 30)
Starting current	[mA]	450 (typical, duration approx. 2 ms; max. 600 at 28.8 V)
Input voltage threshold		
Switching on	[V]	approx. 18
Switching off	[V]	approx. 12.5
Switching time from High to Low (STO-A/B_OFF)	[ms]	10 (typical; maximal 20 at 28.8 V)
Switching time from Low to High (STO-A/B_ON)	[ms]	1 (typical; maximum 5)
Maximum positive test impulse length at logic 0	[µs]	< 300 (related to 24 V nominal voltage and intervals > 2 s between impulses)

Tab. A.25 Technical data: Electrical data for the inputs STO-A and STO-B

<b>Switch-off time to power output stage inactive and maximum tolerance time for test impulse</b>											
Input voltage (STO-A/B)	[V]	19	20	21	22	23	24	25	26	27	28
Typical switch-off time (STO-A/B_OFF)	[ms]	4.0	4.5	5.0	6.0	6.5	7.0	7.5	8.0	8.5	9.5
Maximum tolerance time for test pulse at 24 V signal	[ms]	<2.0	<2.0	2.0	2.5	3.0	3.5	4.5	5.0	5.5	6.0

Tab. A.26 Typical switch-off time and minimum tolerance time for test pulse (OSSD signals)

<b>Acknowledgment contact C1, C2 [X40]</b>	
Version	Relay contact, normally open
Max. voltage	[V DC] < 30 (overvoltage-resistant up to 60 V)
Nominal current	[mA] < 200 (not short-circuit proof)
Voltage drop	[V] ≤ 1
Residual current (contact open)	[µA] < 10
Switching time closing (T_C1/C2_ON)	[ms] < (STO-A/B_OFF <sup>1</sup> ) + 5 ms
Switching time opening (T_C1/C2_OFF)	[ms] < (STO-A/B_ON <sup>1</sup> ) + 5 ms

1) STO-A/B\_OFF, STO-A/B\_ON → Tab. A.25

Tab. A.27 Technical data: Electrical data of the acknowledgment contact C1/C2

<b>Auxiliary supply 24 V, 0 V [X40] – output</b>		
Version		Logic supply voltage routed out of the motor controller (fed in at [X9], not additionally filtered or stabilised). Reverse-polarity protected, overvoltage-proof up to 60 V DC.
Nominal voltage DC	[V]	24
Nominal current	[mA]	100 (short circuit proof, max 300 mA)
Voltage drop	[V]	≤ 1 (for nominal current)

Tab. A.28 Technical data: Electrical data of the auxiliary supply output

<b>Galvanic isolation</b>		
Galvanically isolated potential areas		STO-A / 0V-A
		STO-B / 0V-B
		C1 / C2
		24 V / 0 V (logic supply of the motor controller)

Tab. A.29 Technical data: Galvanic isolation [X40]

<b>Cabling</b>		
Max. cable length	[m]	30
Screening		When wiring outside the control cabinet, use screened cable. Guide screening into the control cabinet / attach to the side of the control cabinet.
Cable cross section (flexible conductors, wire end sleeve with insulating collar)		
One conductor	[mm <sup>2</sup> ]	0.25 ... 0.5
Two conductors	[mm <sup>2</sup> ]	2 x 0.25 (with twin wire end sleeves)
Tightening torque M2	[Nm]	0.22 ... 0.25

Tab. A.30 Technical data: Cabling at [X40]

## A.2 Supported encoders

<b>Resolver</b>			
Type	Protocol	Interface	Comment
Standard	–	[X2A]	Transmission ratio 0.5 ±10 %, excitation voltage 7 Vrms

Tab. A.31 Supported resolvers

<b>Digital encoders</b>			
Type	Protocol	Interface	Comment
Yaskawa Σ-encoder	Yaskawa- OEM protocol	[X2B]	Yaskawa Sigma-1 Type A

Tab. A.32 Supported digital encoders

<b>Analogue encoders</b>			
Type	Protocol	Interface	Comment
ROD 400 ERO 1200, 1300, 1400 ERN 100, 400, 1100, 1300	–	[X2B]	Heidenhain, encoder with zero impulse and reference signal

Tab. A.33 Supported analogue encoders

<b>EnDat encoders</b>			
Type	Protocol	Interface	Comment
ROC 400 ECI 1100, 1300 ECN 100, 400, 1100, 1300	EnDat 2.1 (01/21) EnDat 2.2 (22)	[X2B]	Heidenhain single-turn absolute encoder with/without analogue signal
ROQ 400 EQI 1100, 1300 EQN 100, 400, 1100, 1300	EnDat 2.1 (01/21) EnDat 2.2 (22)	[X2B]	Heidenhain multi-turn absolute encoder with/without analogue signal
LC 100, 400	EnDat 2.1 (01) EnDat 2.2 (22)	[X2B]	Heidenhain absolute length measurement equipment

Tab. A.34 Supported EnDat encoders

<b>HIPERFACE encoders</b>			
Type	Protocol	Interface	Comment
SCS60, 70 SCM60, 70	HIPERFACE	[X2B]	Stegmann single-/multi-turn encoder with analogue incremental signal sine/cosine periods 512. Max. revolutions multi-turn: $\pm 2048$ R
SRS 50, 60, 64 SCKxx SRM 50, 60, 64 SCLxx	HIPERFACE	[X2B]	Stegmann single-/multi-turn encoder with analogue incremental signals. Sine/cosine periods 1024. Max. revolutions multi-turn: $\pm 2048$ R
SKS36 SKM36	HIPERFACE	[X2B]	Stegmann single-/multi-turn encoder with analogue incremental signals. Sine/cosine periods 128. Max. revolutions multi-turn: $\pm 2048$ R
SEK37, 52 SEL37, 52	HIPERFACE	[X2B]	Stegmann single-/multi-turn encoder with analogue incremental signals. Sine/cosine periods 16. Max. revolutions multi-turn: $\pm 2048$ R
L230	HIPERFACE	[X2B]	Stegmann absolute linear encoder with analogue incremental signal measurement step: 156.25 $\mu\text{m}$ . Measuring length max. approx. 40 m.

Tab. A.35 Supported HIPERFACE encoders

<b>BiSS encoder</b>			
Type	Protocol	Interface	Comment
ME 20.20-0.40	BiSS	[X2B]	ELGO magnetic incremental linear encoder (use e.g. for ELGL-LAS...)

Tab. A.36 Supported BiSS encoders



## B Diagnostic messages

If an error occurs, the motor controller CMMP-AS-...-M0 shows a diagnostic message cyclically in the 7-segment display. An error message consists of an E (for Error), a main index and sub-index, e.g.: - **E 0 1 0** -. Warnings have the same number as an error message. In contrast to error messages, however, warnings are preceded and followed by hyphens, e.g. - **1 7 0** -.

### B.1 Explanations of the diagnostic messages

The following table summarises the significance of the diagnostic messages and the actions to be taken in response to them:

Terms	Meaning
No.	Main index (error group) and sub-index of the diagnostic message. Shown in the display, in FCT or diagnostic memory via FHPP.
Code	The Code column includes the error code (Hex) via CiA 301.
Message	Message that is displayed in the FCT.
Cause	Possible causes for the message.
Action	Action by the user.
Reaction	The Reaction column includes the error response (default setting, partially configurable): <ul style="list-style-type: none"> <li>- PS off (switch off output stage),</li> <li>- MCStop (fast stop with maximum current),</li> <li>- QStop (fast stop with parameterised ramp),</li> <li>- Warn (warning),</li> <li>- Ignore (No message, only entry in diagnostic memory),</li> <li>- NoLog (No message and no entry in diagnostic memory).</li> </ul>

Tab. B.1 Explanations of the diagnostic messages

A complete list of the diagnostic messages corresponding to the firmware statuses at the time of printing of this document can be found in section B.2.

## B.2 Diagnostic messages with instructions for fault clearance

Error group 0		Information	
No.	Code	Message	Reaction
0-0	-	<b>Invalid error</b>	
		Cause	Information: An invalid error entry (corrupted) was found in the diagnostic memory marked with this error number. The system time entry is set to 0.
		Action	–
0-1	-	<b>Invalid error detected and corrected</b>	
		Cause	Information: An invalid error entry (corrupted) was found in the diagnostic memory and corrected. The additional information contains the original error number. The system time entry includes the address of the corrupted error number.
		Action	–
0-2	-	<b>Error cleared</b>	
		Cause	Information: Active errors were acknowledged.
		Action	–
0-7	-	<b>Subsequent entry</b>	
		Cause	Information: → Diagnostic memory entry.
		Action	–
0-8	-	<b>Controller switched on</b>	
		Cause	Information: → Diagnostic memory entry.
		Action	–
0-22	-	<b>Default parameter record loaded</b>	
		Cause	Information: → Diagnostic memory entry.
		Action	–

Error group 1		Stack overflow	
No.	Code	Message	Reaction
1-0	6180h	<b>Stack overflow</b>	
		Cause	– Incorrect firmware? – Sporadic high processor load due to cycle time being too short and specific processor-intensive processes (save parameter set etc.).
		Action	<ul style="list-style-type: none"> <li>• Load an approved firmware.</li> <li>• Reduce the processor load.</li> <li>• Contact Technical Support.</li> </ul>

<b>Error group 2</b>		<b>Undervoltage in intermediate circuit</b>	
No.	Code	Message	Reaction
<b>2-0</b>	3220h	<b>Undervoltage in intermediate circuit</b>	
		Cause	Intermediate circuit voltage falls below the parameterised threshold (→ Additional information). Error priority set too high?
		Action	<ul style="list-style-type: none"> <li>• Quick discharge due to switched-off mains supply.</li> <li>• Check power supply.</li> <li>• Couple intermediate circuits if technically permissible.</li> <li>• Check intermediate circuit voltage (measure).</li> <li>• Check undervoltage monitor (threshold value).</li> </ul>
Additional info	Additional information in PNU 203/213: Upper 16 bits: Status number of internal state machine Lower 16 bits: Intermediate circuit voltage (internal scaling approx. 17.1 digit/V).		

<b>Error group 3</b>		<b>Motor overtemperature</b>	
No.	Code	Message	Reaction
<b>3-0</b>	4310h	<b>Analogue motor overtemperature</b>	
		Cause	Motor overloaded, temperature too high. <ul style="list-style-type: none"> <li>– Motor too hot?</li> <li>– Incorrect sensor?</li> <li>– Sensor defective?</li> <li>– Cable fracture?</li> </ul>
Action	<ul style="list-style-type: none"> <li>• Check parameters (current regulator, current limits).</li> <li>• Check the parametrisation of the sensor or the sensor characteristics.</li> </ul> If the error persists when the sensor is bypassed: Device defective.		
<b>3-1</b>	4310h	<b>Digital motor overtemperature</b>	
		Cause	<ul style="list-style-type: none"> <li>– Motor overloaded, temperature too high.</li> <li>– Suitable sensor or sensor characteristics parametrised?</li> <li>– Sensor defective?</li> </ul>
Action	<ul style="list-style-type: none"> <li>• Check parameters (current regulator, current limits).</li> <li>• Check the parametrisation of the sensor or the sensor characteristics.</li> </ul> If the error persists when the sensor is bypassed: Device defective.		
<b>3-2</b>	4310h	<b>Analogue motor overtemperature: Broken wire</b>	
		Cause	The measured resistance value is above the threshold for wire break detection.
Action	<ul style="list-style-type: none"> <li>• Check the connecting cables of the temperature sensor for wire breaks.</li> <li>• Check the parametrisation (threshold value) for wire break detection.</li> </ul>		

<b>Error group 3</b>		<b>Motor overtemperature</b>	
No.	Code	Message	Reaction
<b>3-3</b>	4310h	<b>Analogue motor overtemperature: Short circuit</b>	
		Cause	The measured resistance value is below the threshold for short circuit detection.
		Action	<ul style="list-style-type: none"> <li>• Check the connecting cables of the temperature sensor for wire breaks.</li> <li>• Check the parametrisation (threshold value) for short circuit detection.</li> </ul>

<b>Error group 4</b>		<b>Intermediate circuit/power unit over-temperature</b>	
No.	Code	Message	Reaction
<b>4-0</b>	4210h	<b>Power end stage over-temperature</b>	
		Cause	Device is overheated <ul style="list-style-type: none"> <li>– Temperature display plausible?</li> <li>– Device fan defective?</li> <li>– Device overloaded?</li> </ul>
		Action	<ul style="list-style-type: none"> <li>• Check installation conditions; are the control cabinet fan filters dirty?</li> <li>• Check the drive layout (due to possible overloading in continuous duty).</li> </ul>
<b>4-1</b>	4280h	<b>Intermediate circuit overtemperature</b>	
		Cause	Device is overheated <ul style="list-style-type: none"> <li>– Temperature display plausible?</li> <li>– Device fan defective?</li> <li>– Device overloaded?</li> </ul>
		Action	<ul style="list-style-type: none"> <li>• Check installation conditions; are the control cabinet fan filters dirty?</li> <li>• Check the drive layout (due to possible overloading in continuous duty).</li> </ul>

<b>Error group 5</b>		<b>Internal power supply</b>	
No.	Code	Message	Reaction
<b>5-0</b>	5114h	<b>Failure of internal voltage 1</b>	
		Cause	Monitoring of the internal power supply has recognised under-voltage. This is either due to an internal defect or an overload/short circuit caused by connected peripherals.
		Action	<ul style="list-style-type: none"> <li>• Check digital outputs and brake output for short circuit or specified load.</li> <li>• Separate device from the entire peripheral equipment and check whether the error is still present after reset. If so, an internal defect is present → Repair by the manufacturer.</li> </ul>

<b>Error group 5</b>		<b>Internal power supply</b>	
No.	Code	Message	Reaction
<b>5-1</b>	5115h	<b>Failure of internal voltage 2</b>	
		Cause	Monitoring of the internal power supply has recognised under-voltage. This is either due to an internal defect or an overload/short circuit caused by connected peripherals.
		Action	<ul style="list-style-type: none"> <li>• Check digital outputs and brake output for short circuit or specified load.</li> <li>• Separate device from the entire peripheral equipment and check whether the error is still present after reset. If so, an internal defect is present → Repair by the manufacturer.</li> </ul>
<b>5-2</b>	5116h	<b>Failure of driver supply</b>	
		Cause	Monitoring of the internal power supply has recognised under-voltage. This is either due to an internal defect or an overload/short circuit caused by connected peripherals.
		Action	<ul style="list-style-type: none"> <li>• Check digital outputs and brake output for short circuit or specified load.</li> <li>• Separate device from the entire peripheral equipment and check whether the error is still present after reset. If so, an internal defect is present → Repair by the manufacturer.</li> </ul>
<b>5-3</b>	5410h	<b>Undervoltage of digital I/O</b>	
		Cause	Overloading of the I/Os? Defective peripheral device?
		Action	<ul style="list-style-type: none"> <li>• Check connected peripherals for short circuit / rated loads.</li> <li>• Check connection of the brake (connected incorrectly?).</li> </ul>
<b>5-4</b>	5410h	<b>Over-current of digital I/O</b>	
		Cause	Overloading of the I/Os? Defective peripheral device?
		Action	<ul style="list-style-type: none"> <li>• Check connected peripherals for short circuit / rated loads.</li> <li>• Check connection of the brake (connected incorrectly?).</li> </ul>
<b>5-5</b>	-	<b>Voltage failure of module in Ext1/Ext2</b>	
		Cause	Defect on the plugged-in interface.
		Action	<ul style="list-style-type: none"> <li>• Interface replacement → Repair by the manufacturer.</li> </ul>
<b>5-6</b>	-	<b>X10, X11 and RS232 supply voltage failure</b>	
		Cause	Overloading through connected peripherals.
		Action	<ul style="list-style-type: none"> <li>• Check pin allocation of the connected peripherals.</li> <li>• Short circuit?</li> </ul>
<b>5-7</b>	-	<b>Safety module internal voltage failure</b>	
		Cause	Defect on the safety module.
		Action	<ul style="list-style-type: none"> <li>• Internal defect → Repair by the manufacturer.</li> </ul>

<b>Error group 5</b>		<b>Internal power supply</b>	
No.	Code	Message	Reaction
<b>5-8</b>	-	<b>Internal undervoltage supply 3 (15V)</b>	
		Cause	Defect in the motor controller.
		Action	• Internal defect → Repair by the manufacturer.
<b>5-9</b>	-	<b>Encoder supply defective</b>	
		Cause	Back measurement of the encoder voltage not OK.
		Action	• Internal defect → Repair by the manufacturer.

<b>Error group 6</b>		<b>Over-current</b>	
No.	Code	Message	Reaction
<b>6-0</b>	2320h	<b>Output stage short circuit</b>	
			PSoff
		Cause	<ul style="list-style-type: none"> <li>– Faulty motor, e.g. winding short circuit due to motor overheating or short to PE inside motor.</li> <li>– Short circuit in the cable or the connecting plugs, i.e. short circuit between motor phases or to the screening/PE.</li> <li>– Output stage defective (short circuit).</li> <li>– Incorrect parameterisation of the current regulator.</li> </ul>
		Action	Dependent on the status of the system → Additional information, cases a) to f).
	Additional info	<p>Actions:</p> <p>a) Error only with active brake chopper: Check external braking resistor for short circuit or insufficient resistance value. Check circuitry of the brake chopper output at the motor controller (bridge, etc.).</p> <p>b) Error message immediately when the power supply is connected: Internal short circuit in the output stage (short circuit of a complete half-bridge). The motor controller can no longer be connected to the power supply; the internal (and possibly external) fuses are tripped. Repair by the manufacturer required.</p> <p>c) Short circuit error message not until the output stage or controller is enabled.</p> <p>d) Disconnection of motor plug [X6] directly at the motor controller. If the error still occurs, there is a fault in the motor controller. Repair by the manufacturer required.</p> <p>e) If the error only occurs when the motor cable is connected: Check the motor and cable for short circuits, e.g. with a multimeter.</p> <p>f) Check parameterisation of the current regulator. Oscillations in an incorrectly parameterised current regulator can generate currents up to the short circuit threshold, usually clearly audible as a high-frequency whistling. Verification, if necessary, with the trace in the FCT (actual active current value).</p>	
<b>6-1</b>	2320h	<b>Brake chopper over-current</b>	
			PSoff
		Cause	Over-current at the brake chopper output.
	Action	<ul style="list-style-type: none"> <li>• Check external braking resistor for short circuit or insufficient resistance value.</li> <li>• Check circuitry of the brake chopper output at the motor controller (bridge, etc.).</li> </ul>	

<b>Error group 7</b>		<b>Overvoltage in intermediate circuit</b>	
No.	Code	Message	Reaction
<b>7-0</b>	3210h	<b>Overvoltage in intermediate circuit</b>	
		Cause	Braking resistor is overloaded; too much braking energy, which cannot be dissipated quickly enough. <ul style="list-style-type: none"> <li>– Resistor capacity is incorrect?</li> <li>– Resistor not connected correctly?</li> <li>– Check design (application).</li> </ul>
		Action	<ul style="list-style-type: none"> <li>• Check the design of the braking resistor; resistance value may be too great.</li> <li>• Check the connection to the braking resistor (internal/external).</li> </ul>

<b>Error group 8</b>		<b>Angle encoder</b>	
No.	Code	Message	Reaction
<b>8-0</b>	7380h	<b>Resolver angular encoder error</b>	
		Cause	Resolver signal amplitude is faulty.
		Action	Step-by-step procedure → Additional information, cases a) to c).
		Additional info	<p>a) If possible, test with a different (error-free) resolver (replace the connecting cable, too). If the error still occurs, there is a fault in the motor controller. Repair by the manufacturer required.</p> <p>b) If the error occurs only with a special resolver and its connecting cable: Check resolver signals (carrier and SIN/COS signal), see specification. If the signals do not comply with the signal specifications, replace the resolver.</p> <p>c) If the error recurs sporadically, check the screen bonding or check whether the resolver simply has an insufficient transmission ratio (standard resolver: A = 0.5).</p>



<b>Error group 8</b>		<b>Angle encoder</b>		
No.	Code	Message	Reaction	
<b>8-1</b>	-	<b>Sense of rotation of the serial and incremental position evaluation is not identical</b>		configurable
		Cause	Only encoders with serial position transmission combined with an analogue SIN/COS signal track: The directions of rotation for position determination in the encoder and for incremental evaluation of the analogue track system in the motor controller are the wrong way round → Additional information.	
		Action	Swap the following signals on the [X2B] angle encoder interface (the wires in the connecting plug must be changed around), observing the technical data for the angle encoder where applicable: <ul style="list-style-type: none"> <li>– Swap SIN/COS track.</li> <li>– Swap the SIN+/SIN- or COS+/COS- signals, as applicable.</li> </ul>	
		Additional info	The encoder counts internally, for example positively in clockwise rotation, while the incremental evaluation counts in negative direction with the same mechanical rotation. The interchange of the direction of rotation is detected mechanically at the first movement of over 30°, and the error is triggered.	
<b>8-2</b>	7382h	<b>Error in incremental encoder tracking signals Z0</b>		configurable
		Cause	Signal amplitude of the Z0 track at [X2B] is faulty. <ul style="list-style-type: none"> <li>– Angle encoder connected?</li> <li>– Angle encoder cable defective?</li> <li>– Angle encoder defective?</li> </ul>	
		Action	Check configuration of angle encoder interface: <ol style="list-style-type: none"> <li>a) Z0 evaluation activated, but no track signals connected or present → Additional information.</li> <li>b) Encoder signals faulty?</li> <li>c) Test with another encoder.</li> </ol> → Tab. B.2, page 120.	
		Additional info	For example, EnDat 2.2 or EnDat 2.1 without analogue track. Heidenhain encoder: Order codes EnDat 22 and EnDat 21. With these encoders there are no incremental signals, even when the cables are connected.	

<b>Error group 8</b>		<b>Angle encoder</b>	
No.	Code	Message	Reaction
<b>8-3</b>	7383h	<b>Error in incremental encoder tracking signals Z1</b>	
			configurable
		Cause	Signal amplitude of the Z1 track at X2B is faulty. <ul style="list-style-type: none"> <li>– Angle encoder connected?</li> <li>– Angle encoder cable defective?</li> <li>– Angle encoder defective?</li> </ul>
		Action	Check configuration of angle encoder interface: a) Z1 evaluation activated but not connected. b) Encoder signals faulty? c) Test with another encoder. → Tab. B.2, page 120.
<b>8-4</b>	7384h	<b>Digital incremental encoder track signals error [X2B]</b>	
			configurable
		Cause	Faulty A, B, or N track signals at [X2B]. <ul style="list-style-type: none"> <li>– Angle encoder connected?</li> <li>– Angle encoder cable defective?</li> <li>– Angle encoder defective?</li> </ul>
		Action	Check the configuration of the angle encoder interface. b) Encoder signals faulty? b) Test with another encoder. → Tab. B.2, page 120.
<b>8-5</b>	7385h	<b>Error in incremental encoder of Hall-effect encoder signals</b>	
			configurable
		Cause	Hall encoder signals of a dig. Inc. at [X2B] faulty. <ul style="list-style-type: none"> <li>– Angle encoder connected?</li> <li>– Angle encoder cable defective?</li> <li>– Angle encoder defective?</li> </ul>
		Action	Check the configuration of the angle encoder interface. b) Encoder signals faulty? b) Test with another encoder. → Tab. B.2, page 120.

<b>Error group 8</b>		<b>Angle encoder</b>	
No.	Code	Message	Reaction
<b>8-6</b>	7386h	<b>Angle encoder communication fault</b>	
			configurable
		Cause	<p>Communication to serial angle encoders is disrupted (EnDat encoders, HIPERFACE encoders, BiSS encoders).</p> <ul style="list-style-type: none"> <li>– Angle encoder connected?</li> <li>– Angle encoder cable defective?</li> <li>– Angle encoder defective?</li> </ul>
		Action	<p>Check configuration of the angle encoder interface, procedure corresponding to a) to c):</p> <p>a) Serial encoder parameterised but not connected? Incorrect serial protocol selected?</p> <p>b) Encoder signals faulty?</p> <p>c) Test with another encoder.</p> <p>➔ Tab. B.2, page 120.</p>
<b>8-7</b>	7387h	<b>Signal amplitude of incremental tracks faulty [X10]</b>	
			configurable
		Cause	<p>Faulty A, B, or N track signals at [X10].</p> <ul style="list-style-type: none"> <li>– Angle encoder connected?</li> <li>– Angle encoder cable defective?</li> <li>– Angle encoder defective?</li> </ul>
		Action	<p>Check the configuration of the angle encoder interface.</p> <p>b) Encoder signals faulty?</p> <p>b) Test with another encoder.</p> <p>➔ Tab. B.2, page 120.</p>
<b>8-8</b>	7388h	<b>Internal angle encoder error</b>	
			configurable
		Cause	<p>Internal monitoring of the angle encoder [X2B] has detected an error and forwarded it via serial communication to the controller.</p> <ul style="list-style-type: none"> <li>– Declining illumination intensity with visual encoders?</li> <li>– Excess rotational speed?</li> <li>– Angle encoder defective?</li> </ul>
		Action	<p>If the error occurs repeatedly, the encoder is defective.</p> <p>➔ Replace encoder.</p>

Error group 8		Angle encoder	
No.	Code	Message	Reaction
8-9	7389h	<b>Angle encoder at [X2B] is not supported</b>	
			configurable
		Cause	<p>Angle encoder type read at [X2B], which is not supported or cannot be used in the desired operating mode.</p> <ul style="list-style-type: none"> <li>– Incorrect or inappropriate protocol type selected?</li> <li>– Firmware does not support the connected encoder model?</li> </ul>
		Action	<p>Depending on the additional information of the error message                      → Additional information:</p> <ul style="list-style-type: none"> <li>• Load appropriate firmware.</li> <li>• Check/correct the configuration for encoder evaluation.</li> <li>• Connect an appropriate encoder type.</li> </ul>
Additional info	<p>Additional info (PNU 203/213):</p> <p>0001: HIPERFACE: Encoder type is not supported by the firmware                      → Connect another encoder type or load more recent firmware, if applicable.</p> <p>0002: EnDat: The address space in which the encoder parameter would have to lie does not exist with the connected EnDat encoder → Check the encoder type.</p> <p>0003: EnDat: Encoder type is not supported by the firmware                      → Connect another encoder type or load more recent firmware, if applicable.</p> <p>0004: EnDat: Encoder rating plate cannot be read from the connected encoder. → Replace encoder or load more recent firmware, if applicable.</p> <p>0005: EnDat: EnDat 2.2 interface parameterised, but connected encoder supports only EnDat 2.1. → Change encoder type or reparameterise to EnDat 2.1.</p> <p>0006: EnDat: EnDat2.1 interface with analogue track evaluation parameterised, but according to rating plate the connected encoder does not support track signals. → Replace encoder or switch off Z0 track signal evaluation.</p> <p>0007: Code length measuring system with EnDat2.1 connected, but parameterised as a purely serial encoder. Purely serial evaluation is not possible due to the long response times of this encoder system. Encoder must be operated with analogue tracking signal evaluation → Connect to analogue Z0 tracking signal evaluation.</p>		

<b>Error group 9</b>		<b>Angle encoder parameter set</b>	
No.	Code	Message	Reaction
<b>9-0</b>	73A1h	<b>Old angle encoder parameter set</b>	
		Cause	Warning: An encoder parameter record in an old format was found in the EEPROM of the connected encoder. This has now been converted and saved again.
		Action	No activity at this point. The warning should not re-appear when the 24 V supply is switched back on.
<b>9-1</b>	73A2h	<b>Angle encoder parameter record cannot be decoded</b>	
		Cause	Data in the EEPROM of the angle encoder could not be read completely, or access to it was partly refused.
		Action	The EEPROM of the encoder contains data (communication objects) which are not supported by the loaded firmware. The data in question is then discarded. <ul style="list-style-type: none"> <li>• The parameter record can be adapted to the current firmware by writing the encoder data to the encoder.</li> <li>• Alternatively, load appropriate (more recent) firmware.</li> </ul>
<b>9-2</b>	73A3h	<b>Unknown version of angle encoder parameter record</b>	
		Cause	The data saved in EEPROM is not compatible with the current version. A data structure was found which is unable to decode the loaded firmware.
		Action	<ul style="list-style-type: none"> <li>• Save the encoder parameters again in order to delete the parameter record in the encoder and replace it with a readable record (this will, however, delete the data in the encoder irreversibly).</li> <li>• Alternatively, load appropriate (more recent) firmware.</li> </ul>
<b>9-3</b>	73A4h	<b>Defective data structure in angle encoder parameter record</b>	
		Cause	Data in EEPROM does not match the stored data structure. The data structure was identified as valid but may be corrupted.
		Action	<ul style="list-style-type: none"> <li>• Save the encoder parameters again in order to delete the parameter record in the encoder and replace it with a readable record. If the error still occurs after that, the encoder may be faulty.</li> <li>• Replace the encoder as a test.</li> </ul>

<b>Error group 9</b>		<b>Angle encoder parameter set</b>	
No.	Code	Message	Reaction
<b>9-4</b>	-	<b>EEPROM data: Erroneous custom specific configuration</b>	
		Cause	Only with specialised motors: The plausibility check returns an error, e.g. because the motor was repaired or exchanged.
		Action	<ul style="list-style-type: none"> <li>• If motor repaired: Carry out homing again and save in the angle encoder, after that (!) save in the motor controller.</li> <li>• If motor exchanged: Parameterise the controller again, then carry out homing again and save in the angle encoder, after that (!) save in the motor controller.</li> </ul>
<b>9-5</b>	-	<b>Read/write error EEPROM parameter record</b>	
		Cause	When reading or writing data to the internal sensor parameter record, an error occurred.
		Action	Occurs on Hiperface sensors: a data field in the sensor EEPROM is not suitable for being interrogated by the firmware or for unknown reasons, no data can be written to the sensor. <ul style="list-style-type: none"> <li>• Send motor to the manufacturer for inspection.</li> </ul>
<b>9-7</b>	73A5h	<b>Write-protected EEPROM angle encoder</b>	
		Cause	Data cannot be saved in the EEPROM of the angle encoder. Occurs with Hiperface encoders.
		Action	A data field in the encoder EEPROM is read-only (e.g. after operation on a motor controller of another manufacturer). No solution possible, encoder memory must be unlocked with a corresponding parameterisation tool (from manufacturer).
<b>9-9</b>	73A6h	<b>Angle encoder's EEPROM too small</b>	
		Cause	It is not possible to save all the data in the EEPROM of the angle encoder.
		Action	<ul style="list-style-type: none"> <li>• Reduce the number of data records to be saved. Please read the documentation or contact Technical Support.</li> </ul>

<b>Error group 10</b>		<b>Velocity Violation</b>	
No.	Code	Message	Reaction
<b>10-0</b>	-	<b>Velocity Violation</b>	
		Cause	<ul style="list-style-type: none"> <li>– Motor racing (“spinning”) because the commutation angle offset is incorrect.</li> <li>– Motor is parametrised correctly but the limit for spinning protection is set too low.</li> </ul>
		Action	<ul style="list-style-type: none"> <li>• Check the commutation angle offset.</li> <li>• Check the limit value setting in the parameters.</li> </ul>

<b>Error group 11</b>		<b>Homing</b>	
No.	Code	Message	Reaction
<b>11-0</b>	8A80h	<b>Error when starting the homing run</b>	
		Cause	Controller enable missing.
		Action	Homing can only be started when closed-loop controller enable is active. <ul style="list-style-type: none"> <li>• Check the condition or sequence.</li> </ul>
<b>11-1</b>	8A81h	<b>Error during homing</b>	
		Cause	Homing was interrupted, e.g. by: <ul style="list-style-type: none"> <li>– Withdrawal of controller enable.</li> <li>– Reference switch is beyond the limit switch.</li> <li>– External stop signal (a phase was aborted during homing).</li> </ul>
		Action	<ul style="list-style-type: none"> <li>• Check homing sequence.</li> <li>• Check arrangement of the switches.</li> <li>• If applicable, lock the stop input during homing if it is not desired.</li> </ul>
<b>11-2</b>	8A82h	<b>Homing: No valid index pulse</b>	
		Cause	Required zero impulse during homing missing.
		Action	<ul style="list-style-type: none"> <li>• Check the zero impulse signal.</li> <li>• Check the angle encoder settings.</li> </ul>
<b>11-3</b>	8A83h	<b>Homing: Timeout</b>	
		Cause	The parameterised maximum time for the homing run was exceeded before homing was completed.
		Action	<ul style="list-style-type: none"> <li>• Check the time setting in the parameters.</li> </ul>
<b>11-4</b>	8A84h	<b>Homing: Incorrect limit switch</b>	
		Cause	<ul style="list-style-type: none"> <li>– Relevant limit switch not connected.</li> <li>– Limit switches swapped?</li> <li>– No reference switch found between the two limit switches.</li> <li>– Reference switch is at the limit switch.</li> <li>– Current position with zero impulse method: Limit switch active in the area of the zero impulse (not permissible).</li> <li>– Both limit switches active at the same time.</li> </ul>
		Action	<ul style="list-style-type: none"> <li>• Check whether the limit switches are connected in the correct direction of travel or whether the limit switches have an effect on the intended inputs.</li> <li>• Reference switch connected?</li> <li>• Check configuration of the reference switches.</li> <li>• Move limit switch so that it is not in the zero pulse area.</li> <li>• Check limit switch parametrisation (N/C contact/N/O contact).</li> </ul>

<b>Error group 11</b>		<b>Homing</b>	
No.	Code	Message	Reaction
<b>11-5</b>	8A85h	<b>Homing: I²t / following error</b>	
		Cause	<ul style="list-style-type: none"> <li>– Acceleration ramps inappropriately parametrised.</li> <li>– Reversing due to premature triggering of following error; check parametrisation of following error.</li> <li>– No reference switch reached between the end stops.</li> <li>– Zero pulse method: End stop reached (here not permissible).</li> </ul>
		Action	<ul style="list-style-type: none"> <li>• Parameterise the acceleration ramps so they are flatter.</li> <li>• Check connection of a reference switch.</li> <li>• Method appropriate for the application?</li> </ul>
<b>11-6</b>	8A86h	<b>Homing: End of search path</b>	
		Cause	The maximum permissible path for the homing run has been travelled without reaching the point of reference or the homing run destination.
		Action	Fault in switch detection. <ul style="list-style-type: none"> <li>• Switch for homing is defective?</li> </ul>
<b>11-7</b>	-	<b>Homing: Error in encoder difference monitoring</b>	
		Cause	Deviation between the actual position value and commutation position is too great. External angle encoder not connected or faulty?
		Action	<ul style="list-style-type: none"> <li>• Deviation fluctuates, e.g. due to gear backlash; cut-off threshold may need to be increased.</li> <li>• Check connection of the actual value encoder.</li> </ul>

<b>Error group 12</b>		<b>CAN communication</b>	
No.	Code	Message	Reaction
<b>12-0</b>	8180h	<b>CAN: Double node number</b>	
		Cause	Node number assigned twice.
		Action	<ul style="list-style-type: none"> <li>• Check the configuration of the stations on the CAN bus.</li> </ul>
<b>12-1</b>	8120h	<b>CAN: Communication error, bus OFF</b>	
		Cause	The CAN chip has switched off communication due to communication errors (BUS OFF).
		Action	<ul style="list-style-type: none"> <li>• Check wiring: Cable specification adhered to, broken cable, maximum cable length exceeded, correct terminating resistors, cable screening earthed, all signals terminated?</li> <li>• Replace device on a test basis. If a different device works without errors with the same cabling, send the device to the manufacturer for inspection.</li> </ul>



<b>Error group 12</b>		<b>CAN communication</b>	
No.	Code	Message	Reaction
<b>12-2</b>	8181h	<b>CAN: Communication error during transmission</b>	
		Cause	The signals are corrupted when transmitting messages. Device boot up is so fast that no other nodes on the bus have yet been detected when the boot-up message is sent.
		Action	<ul style="list-style-type: none"> <li>• Check wiring: Cable specification adhered to, broken cable, maximum cable length exceeded, correct terminating resistors, cable screening earthed, all signals terminated?</li> <li>• Replace device on a test basis. If a different device works without errors with the same cabling, send the device to the manufacturer for inspection.</li> </ul>
<b>12-3</b>	8182h	<b>CAN: Communication error during reception</b>	
		Cause	The signals are corrupted when receiving messages.
		Action	<ul style="list-style-type: none"> <li>• Check wiring: Cable specification adhered to, broken cable, maximum cable length exceeded, correct terminating resistors, cable screening earthed, all signals terminated?</li> <li>• Replace device on a test basis. If a different device works without errors with the same cabling, send the device to the manufacturer for inspection.</li> </ul>
<b>12-4</b>	-	<b>Node guarding telegram not received</b>	
		Cause	Node guarding telegram not received within the parametrised time. Signals corrupted?
		Action	<ul style="list-style-type: none"> <li>• Compare cycle time of the remote frames with that of the controller.</li> <li>• Check: Failure of the controller?</li> </ul>
<b>12-5</b>	-	<b>CAN: RPDO too short</b>	
		Cause	A received RPDO does not contain the parameterised number of bytes.
		Action	The number of parametrised bytes does not match the number of bytes received. <ul style="list-style-type: none"> <li>• Check the parametrisation and correct.</li> </ul>
<b>12-9</b>	-	<b>CAN: Protocol error</b>	
		Cause	Faulty bus protocol.
		Action	<ul style="list-style-type: none"> <li>• Check the parametrisation of the selected CAN bus protocol.</li> </ul>

<b>Error group 13</b>		<b>CAN bus timeout</b>	
No.	Code	Message	Reaction
<b>13-0</b>	-	<b>CAN: Timeout</b>	
		Cause	Error message from manufacturer-specific protocol.
		Action	<ul style="list-style-type: none"> <li>• Check the CAN parameters.</li> </ul>

<b>Error group 14</b>		<b>Identification</b>	
No.	Code	Message	Reaction
<b>14-0</b>	-	<b>Automatic identification of the current regulator: Insufficient intermediate circuit voltage</b>	
		Cause	Current regulator parameters cannot be determined (insufficient supply).
		Action	The available intermediate circuit voltage is too low to carry out the measurement.
<b>14-1</b>	-	<b>Automatic identification of the current regulator: Measurement cycle insufficient</b>	
		Cause	Too few or too many measurement cycles required for the connected motor.
		Action	Automatic determination of parameters has supplied a time constant outside the parameterisable value range. <ul style="list-style-type: none"> <li>The parameters must be manually optimised.</li> </ul>
<b>14-2</b>	-	<b>Automatic identification of the current regulator: Output stage enable could not be issued</b>	
		Cause	The output stage has not been enabled.
		Action	<ul style="list-style-type: none"> <li>Check the connection of DIN4.</li> </ul>
<b>14-3</b>	-	<b>Automatic identification of the current regulator: Output stage was switched off prematurely</b>	
		Cause	Output stage enable was switched off while identification was in progress.
		Action	<ul style="list-style-type: none"> <li>Check the sequence control.</li> </ul>
<b>14-5</b>	-	<b>Automatic identification of the angle encoder: Zero impulse could not be found</b>	
		Cause	The zero impulse could not be found following execution of the maximum permissible number of electrical revolutions.
		Action	<ul style="list-style-type: none"> <li>Check the index pulse signal.</li> <li>Angle encoder parametrised correctly?</li> </ul>
<b>14-6</b>	-	<b>Automatic identification of the angle encoder: Hall signals invalid</b>	
		Cause	Hall signals faulty or invalid. The pulse train and/or segmenting of the Hall signals is inappropriate.
		Action	<ul style="list-style-type: none"> <li>Check connection.</li> <li>Refer to the technical data to check whether the encoder shows three Hall signals with 1205 or 605 segments; if necessary, contact Technical Support.</li> </ul>

<b>Error group 14</b>		<b>Identification</b>	
No.	Code	Message	Reaction
<b>14-7</b>	-	<b>Automatic identification of the angle encoder: Identification not possible</b>	
		Cause	Angle encoder at a standstill.
		Action	<ul style="list-style-type: none"> <li>• Ensure sufficient intermediate circuit voltage.</li> <li>• Encoder cable connected to the right motor?</li> <li>• Motor blocked, e.g. holding brake does not release?</li> </ul>
<b>14-8</b>	-	<b>Automatic identification of the angle encoder: Invalid number of pole pairs</b>	
		Cause	The calculated number of pole pairs lies outside the parameterisable range.
		Action	<ul style="list-style-type: none"> <li>• Compare result with the technical data specifications for the motor.</li> <li>• Check the parametrised number of lines.</li> </ul>

<b>Error group 15</b>		<b>Invalid operation</b>	
No.	Code	Message	Reaction
<b>15-0</b>	6185h	<b>Division by zero</b>	
		Cause	Internal firmware error. Division by 0 when using the math library.
		Action	<ul style="list-style-type: none"> <li>• Load factory settings.</li> <li>• Check the firmware to make sure that released firmware has been loaded.</li> </ul>
<b>15-1</b>	6186h	<b>Mathematical overflow during division</b>	
		Cause	Internal firmware error. Overflow when using the math library.
		Action	<ul style="list-style-type: none"> <li>• Load factory settings.</li> <li>• Check the firmware to make sure that released firmware has been loaded.</li> </ul>
<b>15-2</b>	-	<b>Mathematical underflow</b>	
		Cause	Internal firmware error. Internal correction factors could not be calculated.
		Action	<ul style="list-style-type: none"> <li>• Check the setting of the factor group for extreme values and change if necessary.</li> </ul>

<b>Error group 16</b>		<b>Internal error</b>	
No.	Code	Message	Reaction
<b>16-0</b>	6181h	<b>Error in program execution</b>	
		Cause	Internal firmware error. Error during program execution. Illegal CPU command found in the program sequence.
		Action	<ul style="list-style-type: none"> <li>• In case of repetition, load firmware again. If the error occurs repeatedly, the hardware is defective.</li> </ul>

<b>Error group 16</b>		<b>Internal error</b>	
No.	Code	Message	Reaction
<b>16-1</b>	6182h	<b>Illegal interrupt</b>	
		Cause	Error during program execution. An unused IRQ vector was used by the CPU.
		Action	<ul style="list-style-type: none"> <li>In case of repetition, load firmware again. If the error occurs repeatedly, the hardware is defective.</li> </ul>
<b>16-2</b>	6187h	<b>Initialisation error</b>	
		Cause	Error in initialising the default parameters.
		Action	<ul style="list-style-type: none"> <li>In case of repetition, load firmware again. If the error occurs repeatedly, the hardware is defective.</li> </ul>
<b>16-3</b>	6183h	<b>Unexpected state</b>	
		Cause	Error during periphery access within the CPU or error in the program sequence (illegal branching in case structures).
		Action	<ul style="list-style-type: none"> <li>In case of repetition, load firmware again. If the error occurs repeatedly, the hardware is defective.</li> </ul>

<b>Error group 17</b>		<b>Contouring error limit value exceeded</b>	
No.	Code	Message	Reaction
<b>17-0</b>	8611h	<b>Contouring error limit value exceeded</b>	
		Cause	Comparison threshold for the limit value of the following error exceeded.
		Action	<ul style="list-style-type: none"> <li>Enlarge error window.</li> <li>Parameterise acceleration to be less.</li> <li>Motor overloaded (current limiter from the I<sup>2</sup>t monitoring active?).</li> </ul>
<b>17-1</b>	8611h	<b>Encoder difference monitoring</b>	
		Cause	Deviation between the actual position value and commutation position is too great. External angle encoder not connected or faulty?
		Action	<ul style="list-style-type: none"> <li>Deviation fluctuates, e.g. due to gear backlash; cut-off threshold may need to be increased.</li> <li>Check connection of the actual value encoder.</li> </ul>

<b>Error group 18</b>		<b>Temperature warning threshold</b>	
No.	Code	Message	Reaction
<b>18-0</b>	-	<b>Analogue motor temperature</b>	
		Cause	Motor temperature (analogue) greater than 5° below T <sub>max</sub> .
		Action	<ul style="list-style-type: none"> <li>Check parametrisation of current regulator and/or speed regulator.</li> <li>Motor permanently overloaded?</li> </ul>

<b>Error group 21</b>		<b>Current measurement</b>		
No.	Code	Message	Reaction	
<b>21-0</b>	5280h	<b>Error 1 current measurement U</b>		PSoff
		Cause	Offset for current measurement 1 phase U is too great. The controller carries out offset compensation of the current measurement every time its controller enable is issued. Tolerances that are too large result in an error.	
		Action	If the error occurs repeatedly, the hardware is defective.	
<b>21-1</b>	5281h	<b>Error 1 current measurement V</b>		PSoff
		Cause	Offset for current measurement 1 phase V is too great.	
		Action	If the error occurs repeatedly, the hardware is defective.	
<b>21-2</b>	5282h	<b>Error 2 current measurement U</b>		PSoff
		Cause	Offset for current measurement 2 phase U is too great.	
		Action	If the error occurs repeatedly, the hardware is defective.	
<b>21-3</b>	5283h	<b>Error 2 current measurement V</b>		PSoff
		Cause	Offset for current measurement 2 phase V is too great.	
		Action	If the error occurs repeatedly, the hardware is defective.	

<b>Error group 23</b>		<b>Saving/restoring of the actual position</b>		
No.	Code	Message	Reaction	
<b>23-0</b>	-	<b>Actual position: no valid entry present.</b>		configurable
		Cause	<ul style="list-style-type: none"> <li>– No entry saved after activation.</li> <li>– No position saved because drive was not referenced.</li> <li>– Hardware reset occurred prematurely.</li> </ul>	
		Action	Comply with activation sequence: <ol style="list-style-type: none"> <li>1. Enable function.</li> <li>2. Save and restart.</li> <li>3. Carry out a reference run.</li> </ol>	
<b>23-1</b>	-	<b>Actual position: Invalid checksum</b>		configurable
		Cause	It was not possible to carry out the Save operation.	
		Action	Repeat the activation process. Comply with activation sequence: <ol style="list-style-type: none"> <li>1. Enable function.</li> <li>2. Save and restart.</li> <li>3. Carry out a reference run.</li> </ol>	
<b>23-2</b>	-	<b>Actual position: Flash contents inconsistent</b>		configurable
		Cause	Internal error during Save operation.	
		Action	Repeat the activation process. Comply with activation sequence: <ol style="list-style-type: none"> <li>1. Enable function.</li> <li>2. Save and restart.</li> <li>3. Carry out a reference run.</li> </ol>	

<b>Error group 25</b>		<b>Device type/function</b>	
No.	Code	Message	Reaction
<b>25-0</b>	6080h	<b>Invalid device type</b>	
		Cause	Device coding not recognised or invalid.
		Action	This fault cannot be fixed by the user. <ul style="list-style-type: none"> <li>Send motor controller to the manufacturer.</li> </ul>
<b>25-1</b>	6081h	<b>Device type not supported</b>	
		Cause	Device coding invalid, is not supported by the loaded firmware.
		Action	<ul style="list-style-type: none"> <li>Load up-to-date firmware.</li> <li>If newer firmware is not available, the problem may be a hardware defect. Send motor controller to the manufacturer.</li> </ul>
<b>25-2</b>	6082h	<b>Invalid hardware revision</b>	
		Cause	The controller's hardware version is not supported by the loaded firmware.
		Action	<ul style="list-style-type: none"> <li>Check the firmware version; update the firmware to a more recent version if necessary.</li> </ul>
<b>25-3</b>	6083h	<b>Device with restricted functionality: Firmware cannot be executed</b>	
		Cause	Device is not enabled for this function.
		Action	Device is not unlocked for the desired functionality and may need to be unlocked by the manufacturer. The device must be sent in for this purpose.
<b>25-4</b>	-	<b>Invalid power stage type</b>	
		Cause	<ul style="list-style-type: none"> <li>Power section area in the EEPROM is unprogrammed.</li> <li>Power section is not supported by the firmware.</li> </ul>
		Action	<ul style="list-style-type: none"> <li>Load appropriate firmware.</li> </ul>

<b>Error group 26</b>		<b>Internal data error</b>	
No.	Code	Message	Reaction
<b>26-0</b>	5580h	<b>Missing user parameter set</b>	
		Cause	No valid user parameter set in the flash memory.
		Action	<ul style="list-style-type: none"> <li>Load factory settings.</li> </ul> If the error remains, the hardware may be defective.
<b>26-1</b>	5581h	<b>Checksum error</b>	
		Cause	Checksum error of a parameter set.
		Action	<ul style="list-style-type: none"> <li>Load factory settings.</li> </ul> If the error remains, the hardware may be defective.
<b>26-2</b>	5582h	<b>Flash: Error when writing</b>	
		Cause	Error when writing the internal flash memory.
		Action	<ul style="list-style-type: none"> <li>Execute the last operation again.</li> </ul> If the error appears again, the hardware may be faulty.

<b>Error group 26</b>		<b>Internal data error</b>	
No.	Code	Message	Reaction
<b>26-3</b>	5583h	<b>Flash: Error during deletion</b>	
		Cause	Error during deletion of the internal flash memory.
		Action	<ul style="list-style-type: none"> <li>Execute the last operation again.</li> </ul> If the error appears again, the hardware may be faulty.
<b>26-4</b>	5584h	<b>Flash: Error in internal flash</b>	
		Cause	The default parameter set is corrupted / data error in the FLASH area where the default parameter set is located.
		Action	<ul style="list-style-type: none"> <li>Load firmware again.</li> </ul> If the error appears again, the hardware may be faulty.
<b>26-5</b>	5585h	<b>Missing calibration data</b>	
		Cause	Factory-set calibration parameters incomplete/corrupted.
		Action	This fault cannot be fixed by the user.
<b>26-6</b>	5586h	<b>Missing position data sets</b>	
		Cause	Position data sets incomplete or corrupt.
		Action	<ul style="list-style-type: none"> <li>Load factory settings or</li> <li>save the current parameters again so that the position data is written again.</li> </ul>
<b>26-7</b>	-	<b>Fault in data tables (CAM)</b>	
		Cause	Data for the cam disk is corrupted.
		Action	<ul style="list-style-type: none"> <li>Load factory settings.</li> <li>Reload the parameter set if necessary.</li> </ul> If the error persists, contact Technical Support.

<b>Error group 27</b>		<b>Following error monitoring</b>	
No.	Code	Message	Reaction
<b>27-0</b>	8611h	<b>Following error warning threshold</b>	
		Cause	<ul style="list-style-type: none"> <li>Motor overloaded? Check motor capacity.</li> <li>Acceleration or braking ramps are set too steep.</li> <li>Motor blocked? Commutation angle correct?</li> </ul>
		Action	<ul style="list-style-type: none"> <li>Check the parametrisation of the motor data.</li> <li>Check parametrisation of the following error.</li> </ul>

<b>Error group 28</b>		<b>Operating hours counter</b>	
No.	Code	Message	Reaction
<b>28-0</b>	FF01h	<b>Missing operating hour counter</b>	
		Cause	No record for an operating hour counter could be found in the parameter block. A new operating hour counter was created. Occurs during initial start-up or a processor change.
		Action	Warning only, no further action required.

<b>Error group 28</b>		<b>Operating hours counter</b>	
No.	Code	Message	Reaction
<b>28-1</b>	FF02h	<b>Operating hour counter: Write error</b>	
			configurable
		Cause	The data block in which the operating hour counter is stored could not be written to. Cause unknown; possibly problems with the hardware.
	Action	Warning only, no further action required. If the error occurs again, the hardware may be faulty.	
<b>28-2</b>	FF03h	<b>Operating hour counter corrected</b>	
			configurable
		Cause	The operating hour counter has a backup copy. If the controller's 24 V power supply fails precisely when the operating hour counter is being updated, the written record may be corrupted. In such cases, the controller restores the hours-run meter from the intact backup copy when it restarts.
	Action	Warning only, no further action required.	
<b>28-3</b>	FF04h	<b>Operating hour counter converted</b>	
			configurable
		Cause	Firmware was loaded in which the operating hour counter has a different data format. The next time the controller is switched on, the old hours-run meter record is converted to the new format.
	Action	Warning only, no further action required.	

<b>Error group 29</b>		<b>Memory card</b>	
No.	Code	Message	Reaction
<b>29-0</b>	-	<b>Memory card not present</b>	
			configurable
		Cause	This error is triggered in the following cases: <ul style="list-style-type: none"> <li>– if an action should be carried out on the memory card (load or create DCO file, firmware download), but no memory card is plugged in.</li> <li>– The DIL switch S3 is set to ON but no card is plugged in after the reset/restart.</li> </ul>
	Action	Insert appropriate memory card in the slot. Only if expressly desired!	
<b>29-1</b>	-	<b>Memory card: Initialisation error</b>	
			configurable
		Cause	This error is triggered in the following cases: <ul style="list-style-type: none"> <li>– The memory card could not be initialised. Card type may not be supported!</li> <li>– File system not supported.</li> <li>– Error in relationship with the shared memory.</li> </ul>
	Action	<ul style="list-style-type: none"> <li>• Check card type used.</li> <li>• Connect memory card to a PC and format again.</li> </ul>	



<b>Error group 29</b>		<b>Memory card</b>	
No.	Code	Message	Reaction
<b>29-2</b>	-	<b>Memory card: Data error</b>	
		configurable	
		Cause	<p>This error is triggered in the following cases:</p> <ul style="list-style-type: none"> <li>– A load or storage process is already running, but a new load or storage process is requested. DCO file » Servo</li> <li>– The DCO file to be loaded has not been found.</li> <li>– The DCO file to be loaded is not appropriate for the device.</li> <li>– The DCO file to be loaded is defective.</li> <li>– Servo » DCO file</li> <li>– The memory card is read-only.</li> <li>– Other error while saving the parameter set as a DCO file.</li> <li>– Error in creating the file “INFO.TXT”.</li> </ul>
		Action	<ul style="list-style-type: none"> <li>• Execute load or storage process again after waiting 5 seconds.</li> <li>• Connect memory card to a PC and check the files included.</li> <li>• Remove write protection from the memory card.</li> </ul>
<b>29-3</b>	-	<b>Memory card: Write error</b>	
		configurable	
		Cause	<ul style="list-style-type: none"> <li>– This error is triggered while saving the DCO file or INFO.TXT file if the memory card is discovered to be already full.</li> <li>– The maximum file index (99) already exists. That is, all file indexes are assigned. No filename can be issued!</li> </ul>
		Action	<ul style="list-style-type: none"> <li>• Insert another memory card.</li> <li>• Change filenames.</li> </ul>
<b>29-4</b>	-	<b>Memory card: Firmware download error</b>	
		configurable	
		Cause	<p>This error is triggered in the following cases:</p> <ul style="list-style-type: none"> <li>– No firmware file on the memory card.</li> <li>– The firmware file is not appropriate for the device.</li> <li>– Other error during firmware download, e.g. checksum error with an SRecord, error with flash memory, etc.</li> </ul>
		Action	<ul style="list-style-type: none"> <li>• Connect memory card to PC and transfer firmware file.</li> </ul>

<b>Error group 30</b>		<b>Internal conversion error</b>	
No.	Code	Message	Reaction
<b>30-0</b>	6380h	<b>Internal conversion error</b>	
		Cause	Range exceeded for internal scaling factors, which are dependent on the parametrised controller cycle times.
		Action	<ul style="list-style-type: none"> <li>Check whether extremely short or extremely long cycle times were parametrised.</li> </ul>

<b>Error group 31</b>		<b>I<sup>2</sup>t monitoring</b>	
No.	Code	Message	Reaction
<b>31-0</b>	2312h	<b>Motor I<sup>2</sup>t</b>	
		Cause	I <sup>2</sup> t monitoring of the controller has been triggered. <ul style="list-style-type: none"> <li>Motor/mechanical system blocked or sluggish.</li> <li>Motor under-sized?</li> </ul>
		Action	<ul style="list-style-type: none"> <li>Check power dimensioning of drive package.</li> </ul>
<b>31-1</b>	2311h	<b>I<sup>2</sup>t-servo controller</b>	
		Cause	The I <sup>2</sup> t monitoring is responding frequently. <ul style="list-style-type: none"> <li>Motor controller under-sized?</li> <li>Mechanics stiff?</li> </ul>
		Action	<ul style="list-style-type: none"> <li>Check project engineering of the motor controller,</li> <li>possibly use a more powerful type.</li> <li>Check the mechanical system.</li> </ul>
<b>31-2</b>	2313h	<b>I<sup>2</sup>t-PFC</b>	
		Cause	PFC power rating exceeded.
		Action	<ul style="list-style-type: none"> <li>Parameterise operation without PFC (using FCT).</li> </ul>
<b>31-3</b>	2314h	<b>Braking resistor I<sup>2</sup>t</b>	
		Cause	– Overloading of the internal braking resistor.
		Action	<ul style="list-style-type: none"> <li>Use external braking resistor.</li> <li>Reduce resistance value or use resistor with higher pulse load.</li> </ul>

<b>Error group 32</b>		<b>Intermediate circuit</b>	
No.	Code	Message	Reaction
<b>32-0</b>	3280h	<b>Intermediate circuit charging time exceeded</b>	
			configurable
		Cause	The intermediate circuit could not be charged after the mains voltage was applied. <ul style="list-style-type: none"> <li>– Fuse possibly defective or</li> <li>– Internal braking resistor defective or</li> <li>– In operation with external resistor, the resistor is not connected.</li> </ul>
Action	<ul style="list-style-type: none"> <li>• Check interface to the external braking resistor.</li> <li>• Alternatively, check whether the jumper for the internal braking resistor is in place.</li> </ul> <p>If the interface is correct, the internal braking resistor or the built-in fuse is probably faulty. On-site repair is not possible.</p>		
<b>32-1</b>	3281h	<b>Undervoltage for active PFC</b>	
			configurable
		Cause	The PFC cannot be activated at all until an intermediate circuit voltage of about 130 V DC is reached.
Action	<ul style="list-style-type: none"> <li>• Check power supply.</li> </ul>		
<b>32-5</b>	3282h	<b>Brake chopper overload</b>	
			configurable
		Cause	The extent of utilisation of the brake chopper when quick discharge began was already in the range above 100 %. Quick discharge took the brake chopper to the maximum load limit and was prevented/aborted.
Action	No action required.		
<b>32-6</b>	3283h	<b>Intermediate circuit discharge time exceeded</b>	
			configurable
		Cause	Intermediate circuit could not be quickly discharged. The internal braking resistor may be faulty or, in the case of operation with an external resistor, that resistor is not connected.
Action	<ul style="list-style-type: none"> <li>• Check interface to the external braking resistor.</li> <li>• Alternatively, check whether the jumper for the internal braking resistor is in place.</li> </ul> <p>If the internal resistor has been activated and the jumper has been positioned correctly, the internal braking resistor is probably faulty.</p>		
<b>32-7</b>	3284h	<b>Power supply missing for controller enable</b>	
			configurable
		Cause	Controller enable was issued when the intermediate circuit was still in its charging phase after mains voltage was applied and the mains relay was not yet activated. The drive cannot be enabled in this phase, because the drive is not yet firmly connected to the mains (through the mains relay).
Action	<ul style="list-style-type: none"> <li>• In the application, check whether the mains supply and controller enable signals were sent one quickly after the other.</li> </ul>		

<b>Error group 32</b>		<b>Intermediate circuit</b>	
No.	Code	Message	Reaction
<b>32-8</b>	3285h	<b>Power supply failure during controller enable</b>	
		Cause	Interruptions / failure in the power supply while the controller enable was activated.
		Action	<ul style="list-style-type: none"> <li>• Check power supply.</li> </ul>
<b>32-9</b>	3286h	<b>Phase failure</b>	
		Cause	Failure of one or more phases (only in the case of three-phase supply).
		Action	<ul style="list-style-type: none"> <li>• Check power supply.</li> </ul>

<b>Error group 33</b>		<b>Encoder emulation following error</b>	
No.	Code	Message	Reaction
<b>33-0</b>	8A87h	<b>Encoder emulation following error</b>	
		Cause	The critical frequency for encoder emulation was exceeded (see manual) and the emulated angle at [X11] was no longer able to follow. Can occur if very high numbers of lines are programmed for [X11] and the drive reaches high speeds.
		Action	<ul style="list-style-type: none"> <li>• Check whether the parametrised number of lines may be too high for the speed being represented.</li> <li>• Reduce the number of lines if necessary.</li> </ul>

<b>Error group 34</b>		<b>Fieldbus synchronisation</b>	
No.	Code	Message	Reaction
<b>34-0</b>	8780h	<b>No synchronisation via fieldbus</b>	
		Cause	When activating the interpolated position mode, the controller could not be synchronised to the fieldbus. <ul style="list-style-type: none"> <li>– The synchronisation messages from the master may have failed or</li> <li>– the IPO interval is not correctly set to the synchronisation interval of the fieldbus.</li> </ul>
		Action	<ul style="list-style-type: none"> <li>• Check the settings for the controller cycle times.</li> </ul>
<b>34-1</b>	8781h	<b>Fieldbus synchronization error</b>	
		Cause	<ul style="list-style-type: none"> <li>– Synchronisation via fieldbus messages during ongoing operation (interpolated position mode) has failed.</li> <li>– Synchronisation messages from master failed?</li> <li>– Synchronisation interval (IPO interval) parametrised too small/ too large?</li> </ul>
		Action	<ul style="list-style-type: none"> <li>• Check the settings for the controller cycle times.</li> </ul>

Error group 35		Linear motor	
No.	Code	Message	Reaction
35-0	8480h	<b>Linear motor spinning protection</b>	
		Cause	Encoder signals are corrupt. The motor may be racing (“spinning”) because the commutation position has been shifted by the faulty encoder signals.
		Action	<ul style="list-style-type: none"> <li>• Check that the installation conforms to the EMC recommendations.</li> <li>• In the case of linear motors with inductive/optical encoders with separately mounted measuring tape and measuring head: Check the mechanical clearance.</li> <li>• In the case of linear motors with inductive encoders, make sure that the magnetic field of the magnets or the motor winding does not leak into the measuring head (this effect usually occurs when high accelerations = high motor current).</li> </ul>
35-5	-	<b>Error during determination of the commutation position</b>	
		Cause	The rotor position could not be identified clearly. <ul style="list-style-type: none"> <li>– The selected method may be inappropriate.</li> <li>– The selected motor current for the identification may not be set appropriately.</li> </ul>
		Action	<ul style="list-style-type: none"> <li>• Check the method for determining the commutation position ➔ Additional information.</li> </ul>
		Additional info	Notes on determining the commutation position: <ol style="list-style-type: none"> <li>a) The alignment method is inappropriate for locked or sluggish drives or drives capable of low-frequency oscillation.</li> <li>b) The microstep method is appropriate for air-core and iron-core motors. As only very small movements are carried out, it works even when the drive is on elastic stops or is locked but can still be moved elastically to some extent. Due to the high excitation frequency, however, the method is very susceptible to oscillations in the case of poorly damped drives. In such cases, you can attempt to reduce the excitation current (%).</li> <li>c) The saturation method uses local occurrences of saturation in the iron of the motor. Recommended for locked drives. Air-core drives are by definition not suitable for this method. If the (iron-core) drive moves too much when locating the commutation position, the measurement result may be adulterated. If this is the case, reduce the excitation current. In the opposite case, if the drive does not move, the excitation current may not be strong enough, causing the saturation to be insufficient.</li> </ol>

<b>Error group 36</b>		<b>Parameter</b>	
No.	Code	Message	Reaction
<b>36-0</b>	6320h	<b>Parameter was limited</b>	
		Cause	An attempt was made to write a value which was outside the permitted limits, so the value was limited.
		Action	<ul style="list-style-type: none"> <li>• Check the user parameter record.</li> </ul>
<b>36-1</b>	6320h	<b>Parameter was not accepted</b>	
		Cause	An attempt was made to write to an object which is “read only” or is not write-capable in the current status (e.g. with controller enable active).
		Action	<ul style="list-style-type: none"> <li>• Check the user parameter record.</li> </ul>

<b>Error group 40</b>		<b>Software end positions</b>	
No.	Code	Message	Reaction
<b>40-0</b>	8612h	<b>Negative software end position reached</b>	
		Cause	The position setpoint value has reached or exceeded the negative software limit switch.
		Action	<ul style="list-style-type: none"> <li>• Check target data.</li> <li>• Check positioning area.</li> </ul>
<b>40-1</b>	8612h	<b>Positive software end position reached</b>	
		Cause	The position setpoint value has reached or exceeded the positive software limit switch.
		Action	<ul style="list-style-type: none"> <li>• Check target data.</li> <li>• Check positioning area.</li> </ul>
<b>40-2</b>	8612h	<b>Positioning beyond negative software end position suppressed</b>	
		Cause	Start of a positioning task was suppressed because the target lies behind the negative software limit switch.
		Action	<ul style="list-style-type: none"> <li>• Check target data.</li> <li>• Check positioning area.</li> </ul>
<b>40-3</b>	8612h	<b>Positioning beyond positive software end position suppressed</b>	
		Cause	The start of a positioning task was suppressed because the target lies behind the positive software limit switch.
		Action	<ul style="list-style-type: none"> <li>• Check target data.</li> <li>• Check positioning area.</li> </ul>

<b>Error group 41</b>		<b>Record linking</b>	
No.	Code	Message	Reaction
<b>41-0</b>	-	<b>Record linking: Synchronisation error</b>	
		Cause	Start of synchronisation without prior sampling pulse.
		Action	<ul style="list-style-type: none"> <li>• Check the parametrisation of the pre-stop path.</li> </ul>

<b>Error group 42</b>		<b>Positioning</b>	
No.	Code	Message	Reaction
<b>42-0</b>	8680h	<b>Positioning: The drive stops automatically because there is no follow-up positioning</b>	
		Cause	The positioning target cannot be reached through the positioning or edge condition options.
		Action	<ul style="list-style-type: none"> <li>• Check parametrisation of the position records in question.</li> </ul>
<b>42-1</b>	8681h	<b>Positioning: Drive stops as rotation reversal is not allowed</b>	
		Cause	The positioning target cannot be reached through the positioning or edge condition options.
		Action	<ul style="list-style-type: none"> <li>• Check parametrisation of the position records in question.</li> </ul>
<b>42-2</b>	8682h	<b>Positioning: Illegal rotation reversal after “stop”</b>	
		Cause	The positioning target cannot be reached through the positioning or edge condition options.
		Action	<ul style="list-style-type: none"> <li>• Check parametrisation of the position records in question.</li> </ul>
<b>42-3</b>	-	<b>Start positioning rejected: Wrong operating mode</b>	
		Cause	Reversing of the operating mode by means of the position record was not possible.
		Action	<ul style="list-style-type: none"> <li>• Check parametrisation of the position records in question.</li> </ul>
<b>42-4</b>	-	<b>Homing required</b>	
		Cause	A normal positioning set was started, but the drive needs a valid reference position before starting.
		Action	<ul style="list-style-type: none"> <li>• Execute new homing.</li> </ul>
<b>42-5</b>	-	<b>Modulo positioning: Direction of rotation not allowed</b>	
		Cause	<ul style="list-style-type: none"> <li>– The positioning target cannot be reached through the positioning or edge condition options.</li> <li>– The calculated direction of rotation is not permitted for the modulo positioning in the set mode.</li> </ul>
		Action	<ul style="list-style-type: none"> <li>• Check the chosen mode.</li> </ul>
<b>42-9</b>	-	<b>Error when starting the positioning task</b>	
		Cause	<ul style="list-style-type: none"> <li>– Acceleration limit value exceeded.</li> <li>– Position record blocked.</li> </ul>
		Action	<ul style="list-style-type: none"> <li>• Check parameterisation and sequence control and correct, if necessary.</li> </ul>

<b>Error group 43</b>		<b>Hardware limit switch</b>	
No.	Code	Message	Reaction
<b>43-0</b>	8081h	<b>Limit switch: Negative setpoint value blocked</b>	
		Cause	Negative hardware limit switch reached.
		Action	<ul style="list-style-type: none"> <li>• Check parametrisation, wiring and limit switches.</li> </ul>

<b>Error group 43</b>		<b>Hardware limit switch</b>	
No.	Code	Message	Reaction
<b>43-1</b>	8082h	<b>Limit switch: Positive setpoint value blocked</b>	
		Cause	Positive hardware limit switch reached.
		Action	<ul style="list-style-type: none"> <li>• Check parametrisation, wiring and limit switches.</li> </ul>
<b>43-2</b>	8083h	<b>Limit switch: Positioning suppressed</b>	
		Cause	<ul style="list-style-type: none"> <li>– The drive has left the intended range of motion.</li> <li>– Technical defect in the system?</li> </ul>
		Action	<ul style="list-style-type: none"> <li>• Check the intended range of motion.</li> </ul>

<b>Error group 44</b>		<b>Cam disks</b>	
No.	Code	Message	Reaction
<b>44-0</b>	-	<b>Fault in the cam disc tables</b>	
		Cause	The cam disc to be started is not available.
		Action	<ul style="list-style-type: none"> <li>• Check transferred cam disc no.</li> <li>• Correct parametrisation.</li> <li>• Correct programming.</li> </ul>
<b>44-1</b>	-	<b>Cam disc: General error homing</b>	
		Cause	– Start of a cam disc, but the drive is not yet referenced.
		Action	<ul style="list-style-type: none"> <li>• Carry out a homing run.</li> </ul>
		Cause	– Start of homing with active cam disc.
		Action	<ul style="list-style-type: none"> <li>• Deactivate cam disk. Then restart cam disc, if necessary.</li> </ul>

<b>Error group 47</b>		<b>Setting up</b>	
No.	Code	Message	Reaction
<b>47-0</b>	-	<b>Setting-up timeout</b>	
		Cause	The speed required for setting-up was not fallen below in time.
		Action	Check processing of the request on the control side.

<b>Error group 48</b>		<b>Homing required</b>	
No.	Code	Message	Reaction
<b>48-0</b>	-	<b>Homing required</b>	
		Cause	An attempt is being made to switch to the speed control or torque control operating mode or to issue the controller enable in one of these operating modes, although the drive requires a valid reference position for this.
		Action	<ul style="list-style-type: none"> <li>• Carry out a homing run.</li> </ul>



Error group 49		DCO file	
No.	Code	Message	Reaction
49-1	-	<b>DCO file: Wrong password</b>	
		Cause	<ul style="list-style-type: none"> <li>– Parameter file with incorrect password should be loaded.</li> <li>– Old parameter file (still no password entered) should be loaded in protected motor controller.</li> </ul>
		Action	Loading only possible with valid password.

Error group 50		CAN communication	
No.	Code	Message	Reaction
50-0	-	<b>Too many synchronous PDOs</b>	
		Cause	<p>More PDOs have been activated than can be processed in the underlying SYNC interval.</p> <p>This message also appears if only one PDO is to be transmitted synchronously, but a high number of other PDOs with a different transmission type have been activated.</p>
		Action	<ul style="list-style-type: none"> <li>• Check the activation of PDOs.</li> </ul> <p>If the configuration is appropriate, the warning can be suppressed using error management.</p> <ul style="list-style-type: none"> <li>• Extend the synchronisation interval.</li> </ul>
50-1	-	<b>SDO errors have occurred</b>	
		Cause	<p>An SDO transfer has caused an SDO abort.</p> <ul style="list-style-type: none"> <li>– Data exceeds the range of values.</li> <li>– Access to non-existent object.</li> </ul>
		Action	<ul style="list-style-type: none"> <li>• Check the command sent.</li> </ul>

Error group 51		Safety module/function	
No.	Code	Message	Reaction
51-0	8091h	<b>No / unknown safety module or driver supply faulty</b>	
		Cause	Internal voltage error of the STO circuit.
		Action	<ul style="list-style-type: none"> <li>• Protection circuit defective. No action possible, please contact Festo. If possible, replace with another motor controller.</li> </ul>

Error group 52		Safety function	
No.	Code	Message	Reaction
52-1	8099h	<b>Safety function: Discrepancy time overrun</b>	
		Cause	– Control ports STO-A and STO-B are not actuated simultaneously.
		Action	<ul style="list-style-type: none"> <li>• Check discrepancy time.</li> </ul>
		Cause	– Control ports STO-A and STO-B are not wired in the same way.
		Action	<ul style="list-style-type: none"> <li>• Check discrepancy time.</li> </ul>

Error group 52		Safety function	
No.	Code	Message	Reaction
52-2	809Ah	<b>Safety function: Failure of driver supply with active PWM control</b>	
		Cause	This error message does not occur with equipment delivered from the factory. It can occur with use of a user-specific device firmware.
		Action	<ul style="list-style-type: none"> <li>The safe status was requested with approved power output stage. Check inclusion in the safety-oriented interface.</li> </ul>

Error group 66		Modbus/TCP	
No.	Code	Message	Reaction
66-0	-	<b>Modbus/TCP: No free TCP/IP instances</b>	
		Cause	Ethernet stack cannot provide the requested TCP connection. Internal device error.
		Action	<ul style="list-style-type: none"> <li>Restart device or restore factory settings.</li> <li>If the error occurs repeatedly, the HW is faulty. It cannot be repaired on-site.</li> </ul>

Error group 67		Modbus/TCP	
No.	Code	Message	Reaction
67-0	-	<b>Modbus/TCP: Timeout TCP/IP</b>	
		Cause	Existing TCP connection between host and controller has been disconnected.
		Action	<ul style="list-style-type: none"> <li>Ethernet cable inserted correctly? Host switched off or no longer accessible?</li> </ul>
67-1	-	<b>Modbus/TCP: Timeout Modbus TCP/IP</b>	
		Cause	TCP connection between host and controller exists, but the host no longer sends any data.
		Action	<ul style="list-style-type: none"> <li>Host crashed?</li> </ul>
67-2	-	<b>Modbus/TCP: Buffer overflow</b>	
		Cause	Internal buffer for processing the data is full. Data is sent from the host faster than the controller can process it.
		Action	<ul style="list-style-type: none"> <li>Reduce the update time of the host.</li> </ul>
67-3	-	<b>Modbus/TCP: Telegram length too short</b>	
		Cause	The data transmitted by the host is too short. Host sends less data than expected by the controller.
		Action	<ul style="list-style-type: none"> <li>Correct the data length in the host.</li> </ul>
67-4	-	<b>Modbus/TCP: Telegram length too long</b>	
		Cause	The data transmitted by the host is too long. Host sends more data than expected by the controller.
		Action	<ul style="list-style-type: none"> <li>Correct the data length in the host.</li> </ul>

<b>Error group 70</b>		<b>FHPP protocol</b>	
No.	Code	Message	Reaction
<b>70-1</b>	-	<b>FHPP: Mathematical error</b>	
		Cause	Overrun/underrun or division by zero during calculation of cyclic data.
		Action	<ul style="list-style-type: none"> <li>• Check the cyclic data.</li> <li>• Check the factor group.</li> </ul>
<b>70-2</b>	-	<b>FHPP: Factor group invalid</b>	
		Cause	Calculation of the factor group leads to invalid values.
		Action	<ul style="list-style-type: none"> <li>• Check the factor group.</li> </ul>
<b>70-3</b>	-	<b>FHPP: Invalid operating mode change</b>	
		Cause	Changing from the current to the desired operating mode is not permitted. <ul style="list-style-type: none"> <li>– Error occurs when the OPM bits in the status S5 'Reaction to fault' or S4 'Operation enabled' are changed.</li> <li>– Exception: In the status SA1 'Ready', the change between 'Record select' and 'Direct Mode' is permissible.</li> </ul>
		Action	<ul style="list-style-type: none"> <li>• Check your application. It may be that not every change is permissible.</li> </ul>

<b>Error group 71</b>		<b>FHPP protocol</b>	
No.	Code	Message	Reaction
<b>71-1</b>	-	<b>FHPP: Wrong receive telegram length</b>	
		Cause	Too little data is being transmitted by the control system (data length too short).
		Action	<ul style="list-style-type: none"> <li>• Check the data length parameterised in the control system for the controller's receive telegram.</li> <li>• Check the configured data length in the FHPP+ Editor of the FCT.</li> </ul>
<b>71-2</b>	-	<b>FHPP: Wrong response telegram length</b>	
		Cause	Too much data is to be transmitted from the motor controller to the control system (data length too great).
		Action	<ul style="list-style-type: none"> <li>• Check the data length parameterised in the control system for the controller's receive telegram.</li> <li>• Check the configured data length in the FHPP+ Editor of the FCT.</li> </ul>

<b>Error group 80</b>		<b>IRQ overflow</b>	
No.	Code	Message	Reaction
<b>80-0</b>	F080h	<b>Current regulator IRQ overflow</b>	
		Cause	The process data could not be calculated in the set current/velocity/position interpolator cycle.
		Action	<ul style="list-style-type: none"> <li>• Please contact Technical Support.</li> </ul>

<b>Error group 80</b>		<b>IRQ overflow</b>	
No.	Code	Message	Reaction
<b>80-1</b>	F081h	<b>Speed regulator IRQ overflow</b>	
		Cause	The process data could not be calculated in the set current/velocity/position interpolator cycle.
		Action	<ul style="list-style-type: none"> <li>• Please contact Technical Support.</li> </ul>
<b>80-2</b>	F082h	<b>Overflow position controller IRQ</b>	
		Cause	The process data could not be calculated in the set current/velocity/position interpolator cycle.
		Action	<ul style="list-style-type: none"> <li>• Please contact Technical Support.</li> </ul>
<b>80-3</b>	F083h	<b>Interpolator IRQ overflow</b>	
		Cause	The process data could not be calculated in the set current/velocity/position interpolator cycle.
		Action	<ul style="list-style-type: none"> <li>• Please contact Technical Support.</li> </ul>

<b>Error group 81</b>		<b>IRQ overflow</b>	
No.	Code	Message	Reaction
<b>81-4</b>	F084h	<b>Low-Level IRQ overflow</b>	
		Cause	The process data could not be calculated in the set current/velocity/position interpolator cycle.
		Action	<ul style="list-style-type: none"> <li>• Please contact Technical Support.</li> </ul>
<b>81-5</b>	F085h	<b>MDC IRQ overflow</b>	
		Cause	The process data could not be calculated in the set current/velocity/position interpolator cycle.
		Action	<ul style="list-style-type: none"> <li>• Please contact Technical Support.</li> </ul>

<b>Error group 82</b>		<b>Internal sequencing control</b>	
No.	Code	Message	Reaction
<b>82-0</b>	-	<b>Internal sequencing control: Process cancelled</b>	
		Cause	IRQ4 overflow (10 ms low-level IRQ).
		Action	<ul style="list-style-type: none"> <li>• Internal process control: Process was interrupted.</li> <li>• Only for information - no measures required.</li> </ul>
<b>82-1</b>	-	<b>Multiple-started CO write access</b>	
		Cause	Parameters in cyclical and acyclical operation are used concurrently.
		Action	<ul style="list-style-type: none"> <li>• Only one parameterisation interface can be used (USB or Ethernet).</li> </ul>

<b>Error group 84</b>		<b>Condition for controller enable</b>	
No.	Code	Message	Reaction
<b>84-0</b>	-	<b>Conditions for controller enable not fulfilled</b>	
		Cause	<p>One or more conditions for controller enable are not fulfilled. These include:</p> <ul style="list-style-type: none"> <li>- DIN4 (output stage enable) is off.</li> <li>- DIN5 (controller enable) is off.</li> <li>- Intermediate circuit not yet loaded.</li> <li>- Encoder is not yet ready for operation.</li> <li>- Angle encoder identification is still active.</li> <li>- Automatic current regulator identification is still active.</li> <li>- Encoder data is invalid.</li> <li>- Status change of the safety function not yet completed.</li> <li>- Firmware or DCO download via Ethernet (TFTP) active.</li> <li>- DCO download onto memory card still active.</li> <li>- Firmware download via Ethernet active.</li> </ul>
		Action	<ul style="list-style-type: none"> <li>• Check status of digital inputs.</li> <li>• Check encoder cables.</li> <li>• Wait for automatic identification.</li> <li>• Wait for completion of the firmware or DCO download.</li> </ul>
			Warn

<b>Error group 90</b>		<b>Internal error</b>	
No.	Code	Message	Reaction
<b>90-0</b>	5080h	<b>External RAM not recognized</b>	
		Cause	<p>External SRAM not detected / not sufficient. Hardware error (SRAM component or board is defective).</p>
		Action	<ul style="list-style-type: none"> <li>• Please contact Technical Support.</li> </ul>
			PSoff
<b>90-2</b>	5080h	<b>Error at FPGA boot-up</b>	
		Cause	<p>The FPGA (hardware) cannot be booted. The FPGA is booted serially when the device is started, but in this case it could not be loaded with data or it reported a checksum error.</p>
		Action	<ul style="list-style-type: none"> <li>• Switch on the device again (24 V). If the error occurs again, the hardware is faulty.</li> </ul>
			PSoff
<b>90-3</b>	5080h	<b>Error at SD-ADU start</b>	
		Cause	<p>SD-ADUs (hardware) cannot be started. One or more SD-ADUs are not supplying any serial data.</p>
		Action	<ul style="list-style-type: none"> <li>• Switch on the device again (24 V). If the error occurs again, the hardware is faulty.</li> </ul>
			PSoff

<b>Error group 90</b>		<b>Internal error</b>	
No.	Code	Message	Reaction
<b>90-4</b>	5080h	<b>SD-ADU synchronisation error after start</b>	
		Cause	SD-ADU (hardware) not synchronous after starting. During operation, the SD-ADUs for the resolver signals continue running with strict synchronisation once they have been initially started synchronously. The SD-ADUs could not be started at the same time during the start phase.
		Action	<ul style="list-style-type: none"> <li>Switch on the device again (24 V). If the error occurs again, the hardware is faulty.</li> </ul>
<b>90-5</b>	5080h	<b>SD-ADU not synchronous</b>	
		Cause	SD-ADU (hardware) not synchronous after starting. During operation, the SD-ADUs for the resolver signals continue running with strict synchronisation once they have been initially started synchronously. This is checked continually during operation and an error is triggered if appropriate.
		Action	<ul style="list-style-type: none"> <li>Possibly a massive EMC coupling.</li> <li>Switch on the device again (24 V). If the error occurs again, the hardware is faulty.</li> </ul>
<b>90-6</b>	5080h	<b>IRQ0 (current regulator): Trigger error</b>	
		Cause	The output stage is not triggering the software IRQ, which then operates the current regulator. Very likely to be a hardware error on the board or in the processor.
		Action	<ul style="list-style-type: none"> <li>Switch on the device again (24 V). If the error occurs again, the hardware is faulty.</li> </ul>
<b>90-9</b>	5080h	<b>Illegal firmware version</b>	
		Cause	A development version compiled for the debugger was loaded regularly.
		Action	<ul style="list-style-type: none"> <li>Check the firmware version, and update the firmware if necessary.</li> </ul>

<b>Error group 91</b>		<b>Initialisation error</b>	
No.	Code	Message	Reaction
<b>91-0</b>	6000h	<b>Processor error</b>	
		Cause	Internal SRAM too small for the compiled firmware. Can only occur with beta versions.
		Action	<ul style="list-style-type: none"> <li>Check the firmware version, and update the firmware if necessary.</li> </ul>

<b>Error group 91</b>		<b>Initialisation error</b>	
No.	Code	Message	Reaction
<b>91-1</b>	-	<b>Memory error when copying</b>	
		Cause	Firmware parts were not copied correctly from the external FLASH into the internal RAM.
		Action	<ul style="list-style-type: none"> <li>Switch on the device again (24 V). If the error occurs repeatedly, check the firmware version and update the firmware if necessary.</li> </ul>
<b>91-2</b>	-	<b>Error when reading the controller/power section coding</b>	
		Cause	The ID-EEPROM in the controller or power section could either not be addressed at all or does not have consistent data.
		Action	<ul style="list-style-type: none"> <li>Switch on the device again (24 V). If the error occurs repeatedly, the hardware is faulty. No repair possible.</li> </ul>
<b>91-3</b>	-	<b>Software initialisation error</b>	
		Cause	One of the following components is missing or could not be initialised: a) Shared memory not available or defective. b) Driver library not available or defective.
		Action	<ul style="list-style-type: none"> <li>Check firmware design, update if necessary.</li> </ul>

<b>Error group 92</b>		<b>Bootloader/firmware update</b>	
No.	Code	Message	Reaction
<b>92-0</b>	-	<b>Error during firmware download</b>	
		Cause	Error during requested firmware download.
		Action	<ul style="list-style-type: none"> <li>Check firmware file.</li> <li>Restart firmware download.</li> </ul>
<b>92-1</b>	-	<b>Error during bootloader update</b>	
		Cause	Error during requested bootloader download.
		Action	<ul style="list-style-type: none"> <li>Restart the bootloader download.</li> <li>Return device to manufacturer for inspection.</li> </ul>

<b>Instructions on actions with the error messages 08-2 ... 08-7</b>	
Action	Notes
<ul style="list-style-type: none"> <li>• Check whether encoder signals are faulty.</li> </ul>	<ul style="list-style-type: none"> <li>– Check the wiring, e.g. are one or more phases of the track signals interrupted or short-circuited?</li> <li>– Check that installation complies with EMC recommendations (cable screening on both sides?).</li> <li>– Only with incremental encoders: With TTL single-ended signals (HALL signals are always TTL single-ended signals): Check whether there might be an excessive voltage drop on the GND line; in this case = signal reference. Check whether there might be an excessive voltage drop on the GND line; in this case = signal reference.</li> <li>– Check the level of supply voltage on the encoder. Sufficient? If not, change the cable diameter (connect unused lines in parallel) or use voltage feedback (SENSE+ and SENSE-).</li> </ul>
<ul style="list-style-type: none"> <li>• Test with other encoders.</li> </ul>	<ul style="list-style-type: none"> <li>– If the error still occurs when the configuration is correct, test with a different (error-free) encoder (replace the connecting cable as well). If the error still occurs, there is a fault in the motor controller. Repair by the manufacturer required.</li> </ul>

Tab. B.2 Instructions on error messages 08-2 ... 08-7



## Index

### A

Allocation of the plug connectors ..... 25

### C

CAN bus [X4] ..... 75

Check operating status ..... 58

Commissioning ..... 56

Communication interfaces ..... 73

Connecting a PC ..... 57

Connecting the power supply ..... 57

Connection: CAN bus [X4] ..... 36

Connection: Encoder [X2B] ..... 33

Connection: I/O communication [X1] ..... 29

Connection: Incremental encoder input [X10] ..... 44

Connection: Incremental encoder output [X11] ..... 45

Connection: Motor [X6] ..... 37

Connection: Resolver [X2A] ..... 32

Connection: Voltage supply [X9] ..... 39

### D

Device view ..... 15

Documentation ..... 6

### E

Electrical installation ..... 23

Emitted interference ..... 51

Encoder connection [X2B] ..... 75

Entire CMMP-AS system ..... 13

ESD ..... 24

ESD protection ..... 55

### G

General information on EMC ..... 51

### I

I/O interface [X1] ..... 73

Installation clearance ..... 22

Installation clearances ..... 19

Instructions on safe and EMC-compliant  
installation ..... 51

Intended use ..... 10

Intermediate circuit coupling ..... 42

### M

Manufacturing year ..... 7

Mechanical installation ..... 19

Mounting clearance ..... 22

### O

Operation and display components ..... 61

Overload current and short-circuit monitoring ..... 59

### P

PFC ..... 41

Product identification ..... 6

### R

Rating plate ..... 6

Resistance to interference ..... 51

Resolver connection [X2A] ..... 74

### S

Service functions and diagnostic messages .. 59

### T

Technical appendix ..... 65

Type codes ..... 7

Reproduction, distribution or sale of this document or communication of its contents to others without express authorization is prohibited. Offenders will be liable for damages. All rights reserved in the event that a patent, utility model or design patent is registered.

Copyright:  
Festo AG & Co. KG  
Postfach  
73726 Esslingen  
Germany

Phone:  
+49 711 347-0

Fax:  
+49 711 347-2144

e-mail:  
[service\\_international@festo.com](mailto:service_international@festo.com)

Internet:  
[www.festo.com](http://www.festo.com)

Original: de