

**Gear units EMGA/EMGC**

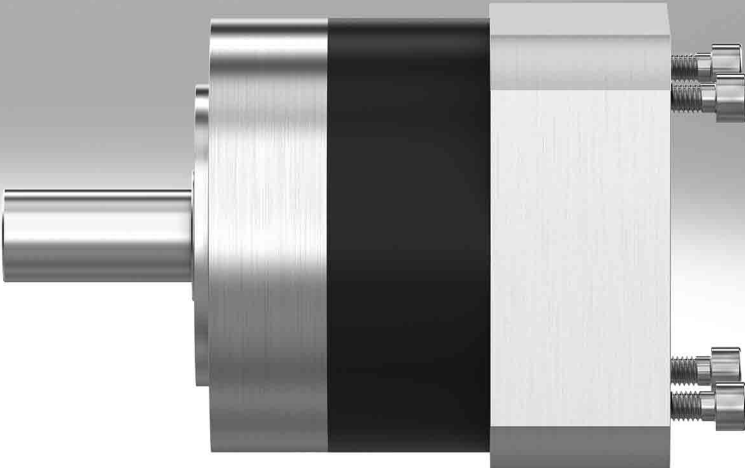

# Gear units EMGA/EMGC

Key features

FESTO

EMGA-...-P-...

→ Page 3



- Planetary gear, straight
- Gear ratio  $i = 3; 5$
- Life-time lubrication
- Degree of protection: IP54

For servo motor EMME-AS, EMMS-AS, EMMT-AS  
For stepper motor EMMS-ST

EMGA-...-A-...

→ Page 9

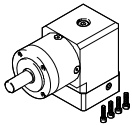

- Right-angle gear unit
- Gear ratio  $i = 3; 5$
- Life-time lubrication
- Degree of protection: IP54

For servo motor EMME-AS, EMMT-AS

EMGC-...-P-...-SEC

→ Page 13



- Planetary gear, straight
- Single-stage or two-stage
- Gear ratio  $i = 3; 4; 5; 7; 12; 16; 20; 25; 35; 40$
- Life-time lubrication
- Degree of protection: IP54

For integrated drive EMCA

EMGC-...-A-...SEC

→ Page 18



- Right-angle gear unit
- Gear ratio  $i = 1$
- Life-time lubrication
- Degree of protection: IP54

For integrated drive EMCA

-  - Note

Other ratios and versions on request

# Gear units EMGA-...-P-...

Type codes

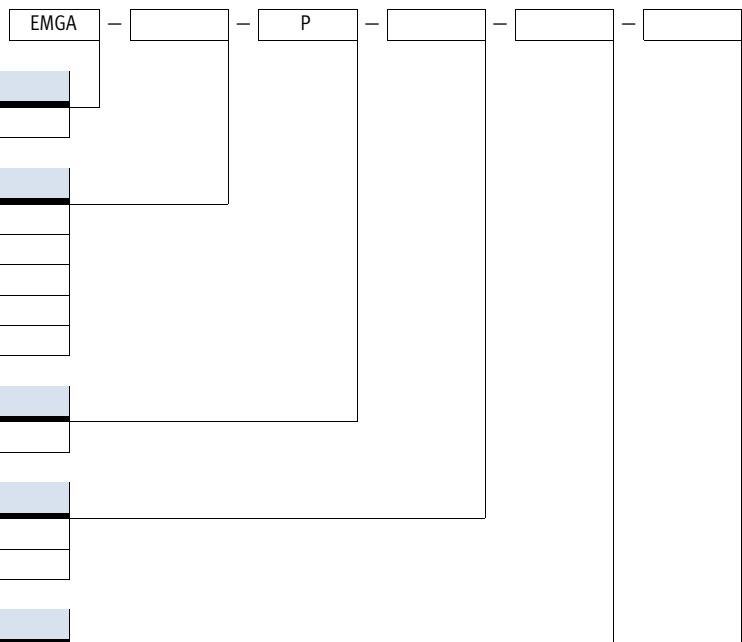

Type	
EMGA	Standard model

Gear unit size	
40	∅ 40 mm
60	∅ 60 mm
80	∅ 80 mm
120	∅ 120 mm
160	∅ 160 mm

Gear unit type	
P	Planetary gear

Gear ratio	
G3	3:1
G5	5:1

Motor interface	
EAS-40	EMME-AS-40
EAS-60	EMME-AS-60, EMMT-AS-60
EAS-80	EMME-AS-80
SAS-40	EMMS-AS-40
SAS-55	EMMS-AS-55
SAS-70	EMMS-AS-70
SAS-100	EMME-AS-100, EMMS-AS-100
SAS-140	EMMS-AS-140
SST-42	EMMS-ST-42
SST-57	EMMS-ST-57
SST-87	EMMS-ST-87

# Gear units EMGA-...-P-...

## Technical data

- For servo motor:  
EMME-AS, EMMS-AS, EMMT-AS
- For stepper motor:  
EMMS-ST



Technical data							
Gear unit size	[mm]	Ø 40		Ø 60		Ø 60	
Gear ratio	[i]	3	5	3	5	3	5
Drive output interface		40G		60H		60G	
Motor interface		EAS-40, SAS-40		EAS-60		SAS-55, SAS-70, SST-57	
Gear unit type		Planetary gear Single-stage					
Continuous output torque <sup>1)</sup>	[Nm]	11	14	28	40	22	
Max. output torque <sup>2)</sup>	[Nm]	17.6	22	45	64	35.2	
Max. rotational speed of drive	[rpm]	18000		13000		13000	
Torsional rigidity	[Nm/arcmin]	1		2.3		2.3	
Torsional backlash	[deg]	0.25		0.17		0.17	
Mass moment of inertia <sup>3)</sup>	[kgcm <sup>2</sup> ]	0.031	0.019	0.135	0.078	0.135	0.078
Max. efficiency	[%]	98					
Operating temperature <sup>4)</sup>	[°C]	-25 ... +90					
Degree of protection		IP54					
Product weight	[g]	350		900		900	
Note on materials		RoHS-compliant					

Gear unit size	[mm]	Ø 80		Ø 120		Ø 160	
Gear ratio	[i]	3	5	3	5	3	5
Drive output interface		80G		120G		160G	
Motor interface		EAS-80, SAS-70, SAS-100, SST-87		SAS-100, SAS-140		SAS-140	
Gear unit type		Planetary gear Single-stage					
Continuous output torque <sup>1)</sup>	[Nm]	85	110	115	195	400	450
Max. output torque <sup>2)</sup>	[Nm]	136	176	184	312	640	720
Max. rotational speed of drive	[rpm]	7000		6500		6500	
Torsional rigidity	[Nm/arcmin]	6		12		38	
Torsional backlash	[deg]	0.12		0.12		0.1	
Mass moment of inertia <sup>3)</sup>	[kgcm <sup>2</sup> ]	0.77	0.45	2.63	1.53	12.14	6.07
Max. efficiency	[%]	98					
Operating temperature <sup>4)</sup>	[°C]	-25 ... +90					
Degree of protection		IP54		IP54			
Product weight	[g]	2100		6000		18000	
Note on materials		RoHS-compliant					

1) At the output shaft  
 2) The specifications refer to an output shaft speed of 100 rpm as well as operating mode S1 and a temperature of 30 °C  
 3) In relation to the drive shaft  
 4) Note the temperature range of the motor

# Gear units EMGA-...-P-...

Technical data

## Dimensions

Download CAD data → [www.festo.com](http://www.festo.com)

EMGA-... for servo motors EMME-AS, EMMT-AS

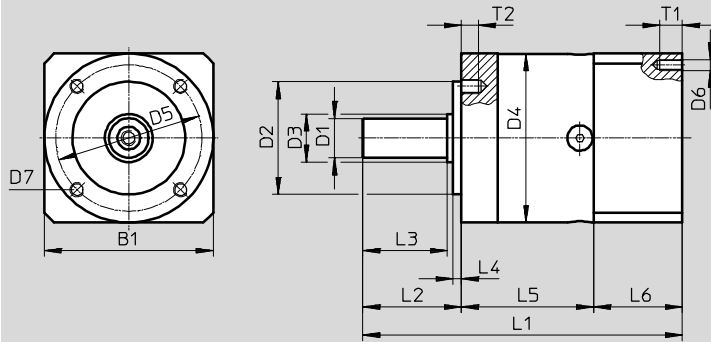

Type	Interface		B1	D1 ∅ h7	D2 ∅ h7	D3 ∅	D4 ∅	D5 ∅	D6
	Drive output	Motor							
EMGA-40-P-G...-EAS-40	40G	EAS-40	40	10	26	12	40	34	M3
EMGA-60-P-G...-EAS-60	60H	EAS-60	60	14	40	17	60	52	M4
EMGA-80-P-G...-EAS-80	80G	EAS-80	80	20	60	25	80	70	M5
EMGA-80-P-G...-SAS-100	80G	SAS-100	100	20	60	25	80	70	M8
EMGA-120-P-G...-SAS-100	120G	SAS-100	115	25	80	35	115	100	M8

Type	D7	L1	L2	L3 ±0.2	L4 ±0.2	L5	L6	T1	T2
EMGA-40-P-G...-EAS-40	M4	93.5	26	23	2	39	28.5	8	6
EMGA-60-P-G...-EAS-60	M5	113.5	35	30	3	47	31	10	8
EMGA-80-P-G...-EAS-80	M6	138.5	40	36	3	60	38.5	12	10
EMGA-80-P-G...-SAS-100	M6	143.5	40	36	3	60	43.5	16	10
EMGA-120-P-G...-SAS-100	M10	176.5	55	50	4	74	47.5	20	16

# Gear units EMGA-...-P-...

Technical data

FESTO

## Dimensions

Download CAD data → [www.festo.com](http://www.festo.com)

EMGA-... for servo motors EMMS-AS

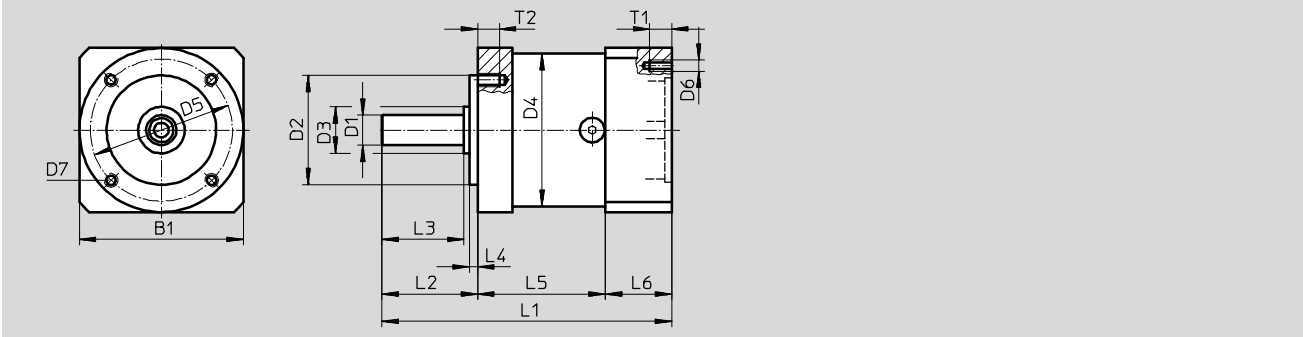

Type	Interface		B1	D1 ∅ h7	D2 ∅ h7	D3 ∅	D4 ∅	D5 ∅	D6
	Drive output	Motor							
EMGA-40-P-G...-SAS-40	40G	SAS-40	40	10	26	12	40	34	M3
EMGA-60-P-G...-SAS-55	60G	SAS-55	60	11	40	17	60	52	M5
EMGA-60-P-G...-SAS-70	60G	SAS-70	70	11	40	17	60	52	M5
EMGA-80-P-G...-SAS-70	80G	SAS-70	80	20	60	25	80	70	M5
EMGA-80-P-G...-SAS-100	80G	SAS-100	100	20	60	25	80	70	M8
EMGA-120-P-G...-SAS-100	120G	SAS-100	115	25	80	35	115	100	M8
EMGA-120-P-G...-SAS-140	120G	SAS-140	140	25	80	35	115	100	M10
EMGA-160-P-G...-SAS-140	160G	SAS-140	140	40	130	55	160	145	M10

Type	D7	L1	L2	L3 ±0.2	L4 ±0.2	L5	L6	T1	T2
EMGA-40-P-G...-SAS-40	M4	88.5±1.5	26±0.6	23	2	39	23.5	6	6
EMGA-60-P-G...-SAS-55	M5	106±1.5	35±0.8	30	3	47	24	12	8
EMGA-60-P-G...-SAS-70	M5	106±1.5	35±0.8	30	3	47	24	12	8
EMGA-80-P-G...-SAS-70	M6	133.5±1.5	40±0.8	36	3	60	33.5	12	10
EMGA-80-P-G...-SAS-100	M6	143.5±1.5	40±0.8	36	3	60	43.5	16	10
EMGA-120-P-G...-SAS-100	M10	176.5±2	55±0.8	50	4	74	47.5	20	16
EMGA-120-P-G...-SAS-140	M10	186±2	55±0.8	50	4	74	57.5	25	16
EMGA-160-P-G...-SAS-140	M12	255.5±2	87±0.8	80	5	104	64.5	25	20

# Gear units EMGA-...-P-...

Technical data

## Dimensions

Download CAD data → [www.festo.com](http://www.festo.com)

EMGA-... for stepper motors EMMS-ST

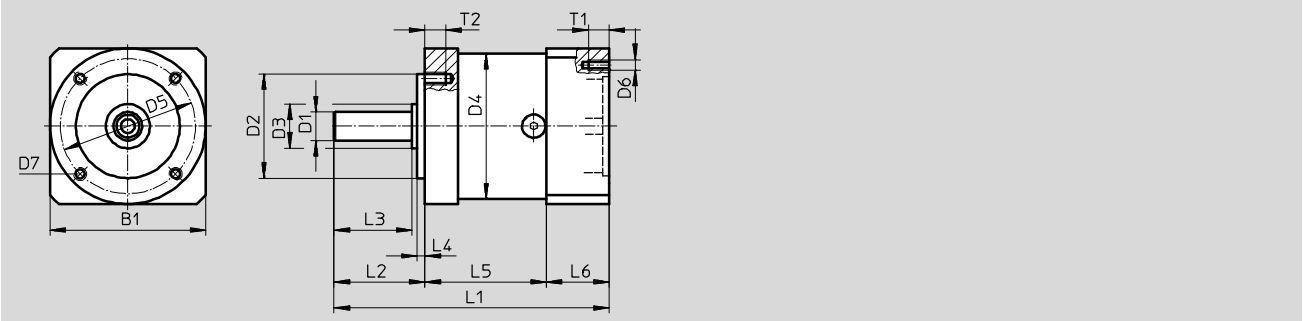

Type	Interface		B1	D1 ∅ h7	D2 ∅ h7	D3 ∅	D4 ∅	D5 ∅	D6
	Drive output	Motor							
EMGA-40-P-G...-SST-42	40G	SST-42	40	10	26	12	40	34	∅3.4
EMGA-60-P-G...-SST-57	60G	SST-57	60	11	40	17	60	52	M4
EMGA-80-P-G...-SST-87	80G	SST-87	90	20	60	25	80	70	M5

Type	D7	L1	L2	L3	L4	L5	L6	T1	T2
		±1.5		±0.2	±0.2				
EMGA-40-P-G...-SST-42	M4	92.5	26±0.6	23	2	39	27.5	5	6
EMGA-60-P-G...-SST-57	M5	106	35±0.8	30	3	47	24	8	8
EMGA-80-P-G...-SST-87	M6	135.5	40±0.8	36	3	60	35.5	12	10

# Gear units EMGA-...-P-...

Technical data

Ordering data					
	Gear ratio	Interface		Part no.	Type
		Drive output	Motor		
For servo motor					
EMME-AS-40	3	40G	EAS-40	★ 2297684	EMGA-40-P-G3-EAS-40
	5	40G	EAS-40	★ 2297685	EMGA-40-P-G5-EAS-40
EMME-AS-60, EMMT-AS-60	3	60H	EAS-60	★ 2297686	EMGA-60-P-G3-EAS-60
	5	60H	EAS-60	★ 2297687	EMGA-60-P-G5-EAS-60
EMME-AS-80	3	80G	EAS-80	★ 2297690	EMGA-80-P-G3-EAS-80
	5	80G	EAS-80	★ 2297691	EMGA-80-P-G5-EAS-80
EMMS-AS-40	3	40G	SAS-40	552186	EMGA-40-P-G3-SAS-40
	5	40G	SAS-40	552187	EMGA-40-P-G5-SAS-40
EMMS-AS-55	3	60G	SAS-55	552188	EMGA-60-P-G3-SAS-55
	5	60G	SAS-55	552189	EMGA-60-P-G5-SAS-55
EMMS-AS-70	3	60G	SAS-70	552190	EMGA-60-P-G3-SAS-70
	5	60G	SAS-70	552191	EMGA-60-P-G5-SAS-70
EMMS-AS-70	3	80G	SAS-70	552192	EMGA-80-P-G3-SAS-70
	5	80G	SAS-70	552193	EMGA-80-P-G5-SAS-70
EMME-AS-100, EMMS-AS-100	3	80G	SAS-100	★ 552194	EMGA-80-P-G3-SAS-100
	5	80G	SAS-100	★ 552195	EMGA-80-P-G5-SAS-100
	3	120G	SAS-100	★ 552196	EMGA-120-P-G3-SAS-100
	5	120G	SAS-100	★ 552197	EMGA-120-P-G5-SAS-100
EMMS-AS-140	3	120G	SAS-140	552198	EMGA-120-P-G3-SAS-140
	5	120G	SAS-140	552199	EMGA-120-P-G5-SAS-140
	3	160G	SAS-140	552200	EMGA-160-P-G3-SAS-140
	5	160G	SAS-140	552201	EMGA-160-P-G5-SAS-140
For stepper motor					
EMMS-ST-42	3	40G	SST-42	★ 549428	EMGA-40-P-G3-SST-42
	5	40G	SST-42	★ 549429	EMGA-40-P-G5-SST-42
EMMS-ST-57	3	60G	SST-57	★ 549430	EMGA-60-P-G3-SST-57
	5	60G	SST-57	★ 549431	EMGA-60-P-G5-SST-57
EMMS-ST-87	3	80G	SST-87	★ 549432	EMGA-80-P-G3-SST-87
	5	80G	SST-87	★ 549433	EMGA-80-P-G5-SST-87

Festo core product range

★ Generally ready for shipping ex works in 24 hours

☆ Generally ready for shipping ex works in 5 days



# Gear units EMGA-...-A-...

Type codes

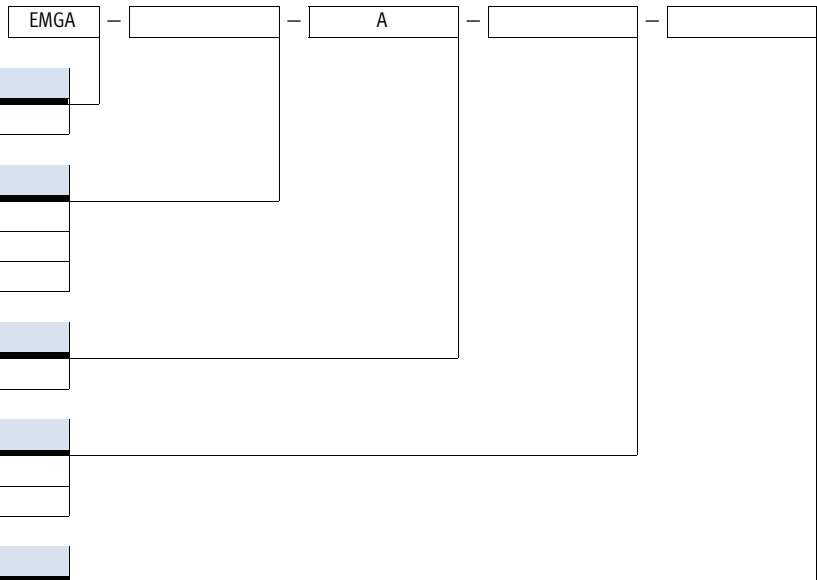

Type	
EMGA	Standard model

Gear unit size	
40	∅ 40 mm
60	∅ 60 mm
80	∅ 80 mm

Gear unit type	
A	Right-angle gear unit

Gear ratio	
G3	3:1
G5	5:1

Motor interface	
40P	EMME-AS-40
60P	EMME-AS-60, EMMT-AS-60
80P	EMME-AS-80
100A	EMME-AS-100, EMMS-AS-100

# Gear units EMGA-...-A-...

## Technical data

- For servo motor:  
EMME-AS, EMMT-AS

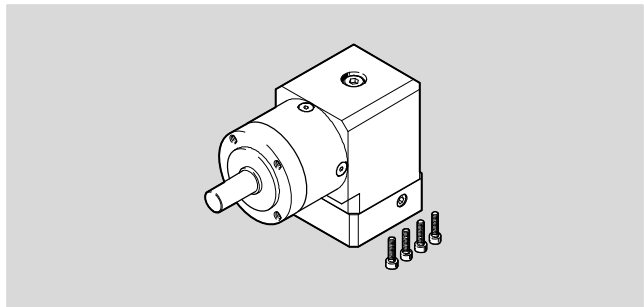

Technical data					
Gear unit size	[mm]	Ø 40		Ø 60	
Gear ratio	[i]	3	5	3	5
Drive output interface		40G		60H	
Motor interface		40P		60P	
Gear unit type		Right-angle gear unit Single-stage			
Continuous output torque <sup>1)</sup>	[Nm]	4.5	7.5	14	24
Max. output torque <sup>2)</sup>	[Nm]	7	12	22	38
Max. rotational speed of drive	[rpm]	18000		13000	
Torsional rigidity	[Nm/arcmin]	0.8		2	1.9
Torsional backlash	[deg]	0.35		0.27	
Mass moment of inertia <sup>3)</sup>	[kgcm <sup>2</sup> ]	0.049	0.035	0.394	0.257
Max. efficiency	[%]	95			
Operating temperature <sup>4)</sup>	[°C]	-25 ... +90			
Degree of protection		IP54			
Product weight	[g]	500		1700	
Note on materials		RoHS-compliant			

Gear unit size	[mm]	Ø 80			
Gear ratio	[i]	3		5	
Drive output interface		80G			
Motor interface		80P, 100A			
Gear unit type		Right-angle gear unit Single-stage			
Continuous output torque <sup>1)</sup>	[Nm]	40		67	
Max. output torque <sup>2)</sup>	[Nm]	64		107	
Max. rotational speed of drive	[rpm]	3500		3600	
Torsional rigidity	[Nm/arcmin]	5		4.8	
Torsional backlash	[deg]	0.22			
Mass moment of inertia <sup>3)</sup>	[kgcm <sup>2</sup> ]	1.409		1.017	
Max. efficiency	[%]	95			
Operating temperature <sup>4)</sup>	[°C]	-25 ... +90			
Degree of protection		IP54			
Product weight	[g]	4300			
Note on materials		RoHS-compliant			

- 1) At the output shaft
- 2) The specifications refer to an output shaft speed of 100 rpm as well as operating mode S1 and a temperature of 30 °C
- 3) In relation to the drive shaft
- 4) Note the temperature range of the motor

# Gear units EMGA-...-A-...

Technical data

FESTO

## Dimensions

Download CAD data → [www.festo.com](http://www.festo.com)

EMGA-... for servo motors EMME-AS, EMMT-AS

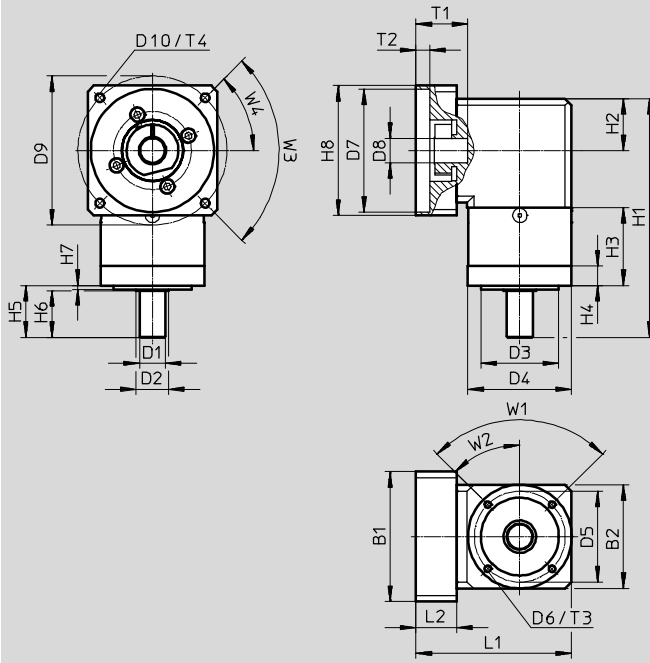

Type	Interface		B1	B2	D1 Ø h7	D2 Ø	D3 Ø h7	D4 Ø
	Drive output	Motor						
EMGA-40-A-G...-40P	40G	40P	40	40	10	12	26	40 <sup>-0.3</sup>
EMGA-60-A-G...-60P	60H	60P	60	60	14	17	40	60 <sup>-0.3</sup>
EMGA-80-A-G...-80P	80G	80P	80	80	20	25	60	80 <sup>-0.4</sup>
EMGA-80-A-G...-100A	80G	100A	100	100	20	25	60	80 <sup>-0.4</sup>

Type	D5 Ø	D6	D7 +0.05/+0.02	D8	D9	D10	H1 ±1.5	H2
EMGA-40-A-G...-40P	34	M4	30	8	45	M3	110	20 <sup>+0.5/-0.7</sup>
EMGA-60-A-G...-60P	52	M5	50	14	70	M4	146.8	30
EMGA-80-A-G...-80P	70	M6	60	19	75	M5	183.9	40
EMGA-80-A-G...-100A	70	M6	95	19	115	M6	183.9	40

Type	H3 ±0.2	H4	H5	H6 ±0.2	H7 ±0.2	H8	L1	L2
EMGA-40-A-G...-40P	39	10.2	26±0.6	23	2	40	67	19
EMGA-60-A-G...-60P	46.8	12.7	35±0.8	30	3	60	92.5	23
EMGA-80-A-G...-80P	59.9	15	40±0.8	36	3	80	110	21.5
EMGA-80-A-G...-100A	59.9	15	40±0.8	36	3	100	120	31.5

Type	T1	T2	T3	T4	W1	W2	W3	W4
EMGA-40-A-G...-40P	25 <sup>+2.5/+0.5</sup>	3.5	6	8	90°	45°	90°	45°
EMGA-60-A-G...-60P	30 <sup>+2/+0.5</sup>	4	8	10	90°	45°	90°	45°
EMGA-80-A-G...-80P	30 <sup>+2/+0.5</sup>	4.4	10	12	90°	45°	90°	45°
EMGA-80-A-G...-100A	40 <sup>+2/+0.5</sup>	10.4	10	20	90°	45°	90°	45°

# Gear units EMGA-...-A-...

Technical data

Ordering data					
	Gear ratio	Interface		Part no.	Type
		Drive output	Motor		
For servo motor					
EMME-AS-40	3	40G	40P	<b>8085342</b>	<b>EMGA-40-A-G3-40P</b>
	5	40G	40P	<b>8085343</b>	<b>EMGA-40-A-G5-40P</b>
EMME-AS-60, EMMT-AS-60	3	60H	60P	<b>8085344</b>	<b>EMGA-60-A-G3-60P</b>
	5	60H	60P	<b>8085345</b>	<b>EMGA-60-A-G5-60P</b>
EMME-AS-80	3	80G	80P	<b>8085346</b>	<b>EMGA-80-A-G3-80P</b>
	5	80G	80P	<b>8085347</b>	<b>EMGA-80-A-G5-80P</b>
EMME-AS-100, EMMS-AS-100	3	80G	100A	<b>8085348</b>	<b>EMGA-80-A-G3-100A</b>
	5	80G	100A	<b>8085349</b>	<b>EMGA-80-A-G5-100A</b>

# Gear units EMGC-...-P-...-SEC

Type codes

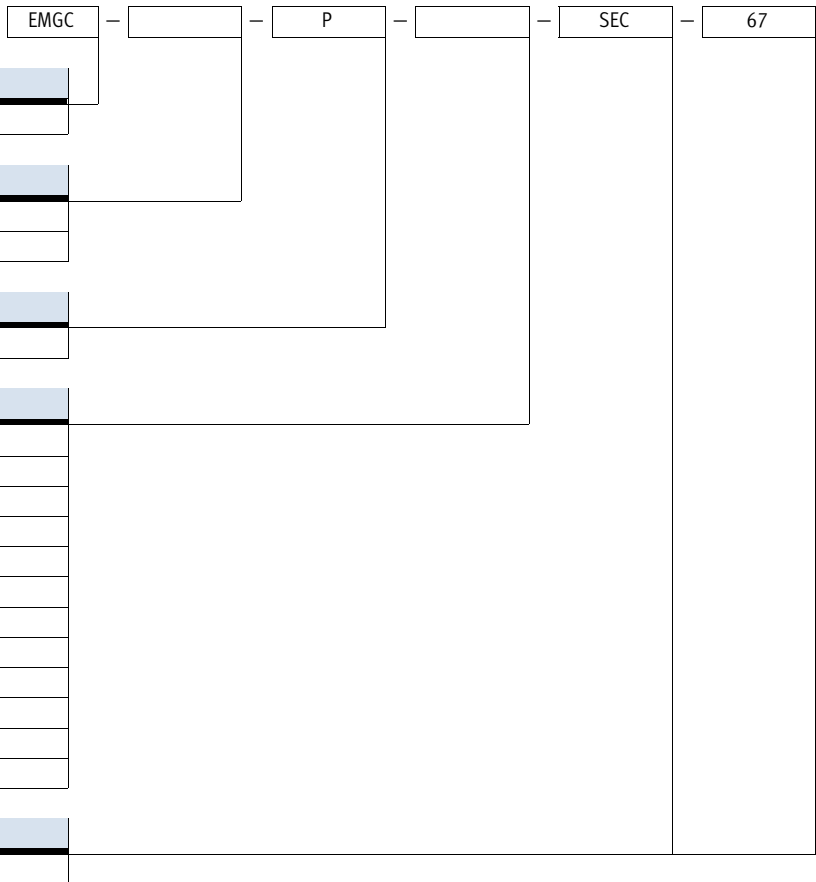

# Gear units EMGC-...-P-...-SEC

Technical data

- For integrated drive:  
EMCA-EC-67



Technical data											
Gear unit size	[mm]	Ø 40									
Gear ratio	[i]	3	4	5	7	12	16	20	25	35	
Drive output interface		40G									
Motor interface		SEC-67									
Gear unit type		Planetary gear									
		Single-stage					Two-stage				
Continuous output torque <sup>1)</sup>	[Nm]	5	6.5	6.5	6.5	10	14	14	14	14	
Max. output torque <sup>2)</sup>	[Nm]	10	13	13	13	12.5	17.5	17.5	17.5	17.5	
Max. rotational speed of drive <sup>3)</sup>	[rpm]	6000									
Torsional rigidity	[Nm/arcmin]	0.85	0.85	0.85	0.65	0.85					
Max. torsional backlash	[deg]	0.5					0.67				
Mass moment of inertia <sup>4)</sup>	[kgcm <sup>2</sup> ]	0.06	0.04	0.04	0.04	0.04					
Max. efficiency	[%]	94					92				
Operating temperature <sup>5)</sup>	[°C]	-20 ... +90									
Degree of protection		IP54									
Product weight	[g]	450					550				
Note on materials		RoHS-compliant									
		Contains PWIS (paint-wetting impairment substances)									

- 1) At the output shaft
- 2) In relation to a rotational speed of 3000 rpm and operating mode S1
- 3) The permissible operating temperature may not be exceeded
- 4) In relation to the drive shaft
- 5) Note the temperature range of the motor

Technical data													
Gear unit size	[mm]	Ø 60											
Gear ratio	[i]	3	4	5	7	10	12	16	20	25	35	40	
Drive output interface		60H											
Motor interface		SEC-67											
Gear unit type		Planetary gear											
		Single-stage						Two-stage					
Continuous output torque <sup>1)</sup>	[Nm]	20	26	26	26	16	36	42	42	44	44	42	
Max. output torque <sup>2)</sup>	[Nm]	36	44	44	44	24	45	52	52	55	55	52	
Max. rotational speed of drive <sup>3)</sup>	[rpm]	6000											
Torsional rigidity	[Nm/arcmin]	2.4	2.4	2.4	1.7	1.3	2.4						
Max. torsional backlash	[deg]	0.5						0.67					
Mass moment of inertia <sup>4)</sup>	[kgcm <sup>2</sup> ]	0.4	0.34	0.32	0.3	0.29	0.34	0.34	0.32	0.32	0.3	0.29	
Max. efficiency	[%]	94						92					
Operating temperature <sup>5)</sup>	[°C]	-20 ... +90											
Degree of protection		IP54											
Product weight	[g]	900						1200					
Note on materials		RoHS-compliant											
		Contains PWIS (paint-wetting impairment substances)											

- 1) At the output shaft
- 2) In relation to a rotational speed of 3000 rpm and operating mode S1
- 3) The permissible operating temperature may not be exceeded
- 4) In relation to the drive shaft
- 5) Note the temperature range of the motor

# Gear units EMGC-...-P-...-SEC

Technical data

## Dimensions

Download CAD data → [www.festo.com](http://www.festo.com)

EMGC-40-P-... for integrated drives EMCA-EC-67

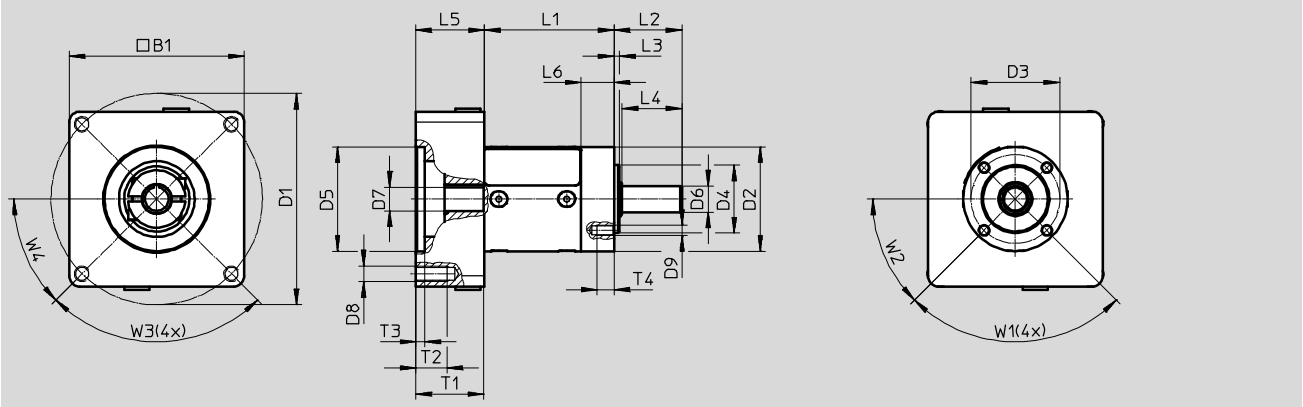

Type	Interface		B1	D1 ∅ ±0.1	D2 ∅ -0.1	D3 ∅ ±0.1	D4 ∅ h6	D5 ∅ G7	D6 ∅ h7
	Drive output	Motor							
EMGC-40-P-...-SEC-67	40G	SEC-67	67	81	40	34	26	40	10

Type	D7 ∅ G6	D8	D9	L2 -0.3	L3 ±0.2	L4 -0.1	L5	L6
EMGC-40-P-...-SEC-67	9	M6	M4	26	2	23	26.3	12.7

Type	T1	T2	T3 +0.2	T4	W1	W2	W3	W4
EMGC-40-P-...-SEC-67	26	13	3.5	6.5	90°	45°	90°	45°

Type	L1 ±0.5
EMGC-40-P-G3-SEC-67	49.7
EMGC-40-P-G4-SEC-67	
EMGC-40-P-G5-SEC-67	
EMGC-40-P-G7-SEC-67	
EMGC-40-P-G12-SEC-67	65.3
EMGC-40-P-G16-SEC-67	
EMGC-40-P-G20-SEC-67	
EMGC-40-P-G25-SEC-67	
EMGC-40-P-G35-SEC-67	

# Gear units EMGC-...-P-...-SEC

Technical data



## Dimensions

Download CAD data → [www.festo.com](http://www.festo.com)

EMGC-60-P-... for integrated drives EMCA-EC-67

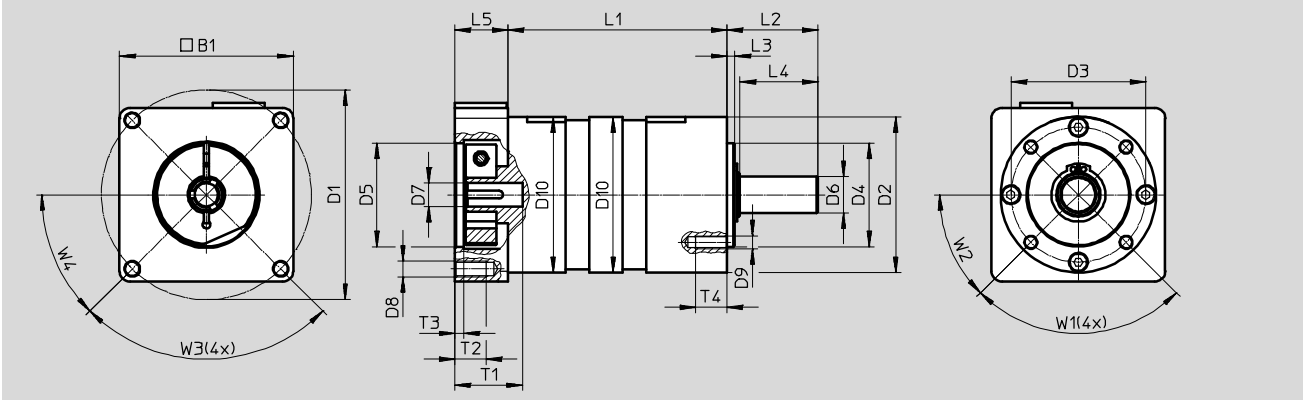

Type	Interface		B1	D1 ∅ ±0.1	D2 ∅ -0.1	D3 ∅ ±0.1	D4 ∅ h6	D5 ∅ G7	D6 ∅ h6
	Drive output	Motor							
EMGC-60-P-...-SEC-67	60H	SEC-67	67	81	60	52	40	40	14

Type	D7 ∅ G6	D8	D9	D10 ∅	L2	L3	L4	L5
EMGC-60-P-...-SEC-67	9	M6	M5	60	-0.3	±0.2	-0.1	20.5

Type	T1	T2	T3	T4	W1	W2	W3	W4
EMGC-60-P-...-SEC-67	26.1	13	3.5 +0.2	12	90°	45°	90°	45°

Type	L1
	±0.5
EMGC-60-P-G3-SEC-67	62.5
EMGC-60-P-G4-SEC-67	
EMGC-60-P-G5-SEC-67	
EMGC-60-P-G7-SEC-67	
EMGC-60-P-G10-SEC-67	
EMGC-60-P-G12-SEC-67	84.5
EMGC-60-P-G16-SEC-67	
EMGC-60-P-G20-SEC-67	
EMGC-60-P-G25-SEC-67	
EMGC-60-P-G35-SEC-67	
EMGC-60-P-G40-SEC-67	



# Gear units EMGC-...-P-...-SEC

Technical data

Ordering data						
For integrated drive	Gear ratio		Interface		Part no.	Type
			Drive output	Motor		
EMCA-EC-67	3	Single-stage	40G	SEC-67	8000594	EMGC-40-P-G3-SEC-67
	4				8000595	EMGC-40-P-G4-SEC-67
	5				8000596	EMGC-40-P-G5-SEC-67
	7				8000597	EMGC-40-P-G7-SEC-67
	12	Two-stage	40G	SEC-67	8000598	EMGC-40-P-G12-SEC-67
	16				8000599	EMGC-40-P-G16-SEC-67
	20				8000600	EMGC-40-P-G20-SEC-67
	25				8000601	EMGC-40-P-G25-SEC-67
	35				8000602	EMGC-40-P-G35-SEC-67
	EMCA-EC-67	3	Single-stage	60H	SEC-67	8000612
4		8000613				EMGC-60-P-G4-SEC-67
5		8000614				EMGC-60-P-G5-SEC-67
7		8000615				EMGC-60-P-G7-SEC-67
10		8000616				EMGC-60-P-G10-SEC-67
12		Two-stage	60H	SEC-67	8000617	EMGC-60-P-G12-SEC-67
16					8000618	EMGC-60-P-G16-SEC-67
20					8000619	EMGC-60-P-G20-SEC-67
25					8000620	EMGC-60-P-G25-SEC-67
35					8000621	EMGC-60-P-G35-SEC-67
40				8000622	EMGC-60-P-G40-SEC-67	

# Gear units EMGC-...-A-...-SEC

Type codes

EMGC – 67 – A – G1 – SEC – 67

**Type**

EMGC	Standard model
------	----------------

**Gear unit size**

67	67 mm
----	-------

**Gear unit type**

A	Right-angle gear unit
---	-----------------------

**Gear ratio**

G1	1:1
----	-----

**Motor interface**

SEC-67	EMCA-EC-67
--------	------------

# Gear units EMGC-...-A-...-SEC

Technical data

- For integrated drive:  
EMCA-EC-67



Technical data		
Gear unit size	[mm]	67
Gear ratio	[i]	1
Drive output interface		67A
Motor interface		SEC-67
Gear unit type		Right-angle gear unit Single-stage
Continuous output torque <sup>1)</sup>	[Nm]	2
Max. output torque <sup>2)</sup>	[Nm]	2.1
Max. rotational speed of drive <sup>3)</sup>	[rpm]	4500
Torsional rigidity	[Nm/arcmin]	0.105
Max. torsional backlash	[deg]	0.67
Mass moment of inertia <sup>4)</sup>	[kgcm <sup>2</sup> ]	0.09
Max. efficiency	[%]	90
Operating temperature <sup>5)</sup>	[°C]	-20 ... +90
Degree of protection		IP54
Product weight	[g]	930
Note on materials		RoHS-compliant Contains PWIS (paint-wetting impairment substances)

- 1) At the output shaft
- 2) In relation to a rotational speed of 3000 rpm and operating mode S1
- 3) The permissible operating temperature may not be exceeded
- 4) In relation to the drive shaft
- 5) Note the temperature range of the motor

# Gear units EMGC-...-A-...-SEC

Technical data



## Dimensions

Download CAD data → [www.festo.com](http://www.festo.com)

EMGC-67... for integrated drives EMCA-EC-67

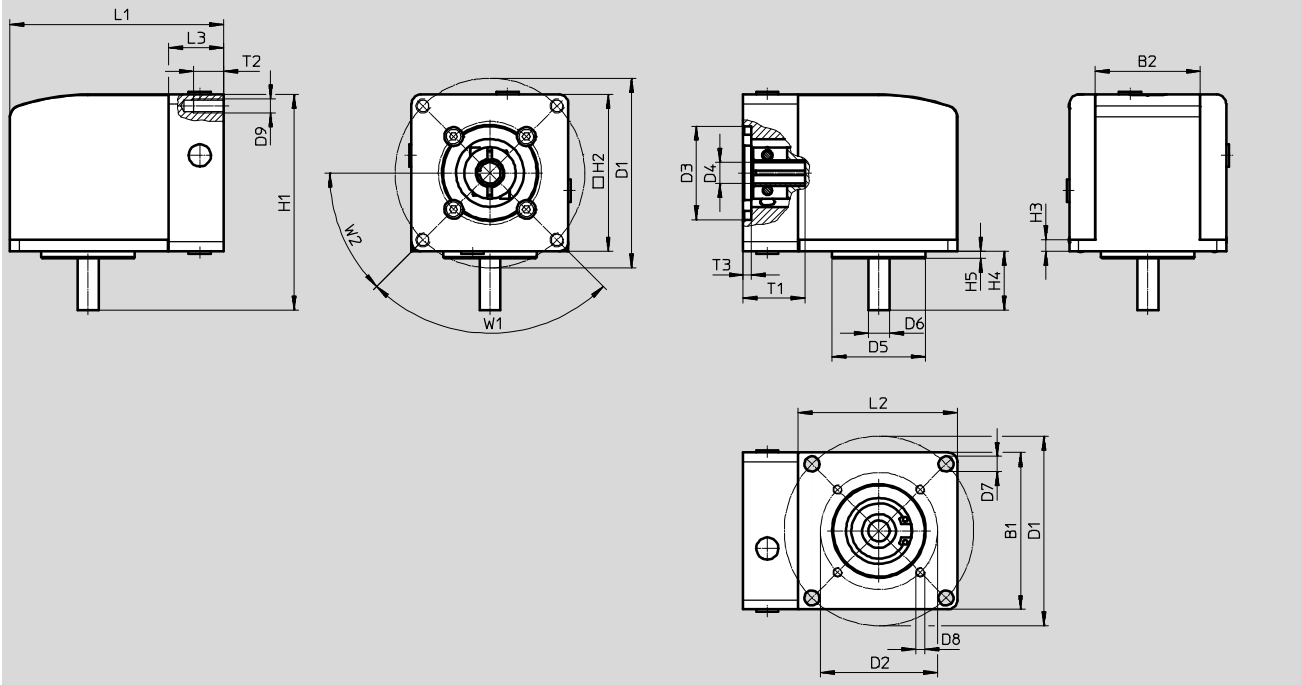

Type	Interface		B1	B2	D1	D2	D3	D4
	Drive output	Motor						
EMGC-67-A-G1-SEC-67	67A	SEC-67	67	±0.2	∅ ±0.1	∅ ±0.1	∅ G7	∅ G6

Type	D5	D6	D7	D8	D9	H1	H2	H3	H4
	∅ h7	∅ h7	∅ H12					±0.1	-0.1
EMGC-67-A-G1-SEC-67	40	9	6.4	M4	M6	92	67	5	25

Type	H5	L1	L2	L3	T1	T2	T3	W1	W2
							+0.2		
EMGC-67-A-G1-SEC-67	3	91.5	68	23.5	26.3	13	3.5	90°	45°

## Ordering data

For integrated drive	Gear ratio	Interface		Part no.	Type
		Drive output	Motor		
EMCA-EC-67	1	67A	SEC-67	2321480	EMGC-67-A-G1-SEC-67

# Festo - Your Partner in Automation



**1 Festo Inc.**  
5300 Explorer Drive  
Mississauga, ON L4W 5G4  
Canada

**Festo Customer Interaction Center**  
Tel: 1 877 463 3786  
Fax: 1 877 393 3786  
Email: [customer.service.ca@festo.com](mailto:customer.service.ca@festo.com)



**2 Festo Pneumatic**  
Av. Ceylán 3,  
Col. Tequesquináhuac  
54020 Tlalneantla,  
Estado de México

**Multinational Contact Center**  
01 800 337 8669  
[ventas.mexico@festo.com](mailto:ventas.mexico@festo.com)



**3 Festo Corporation**  
1377 Motor Parkway  
Suite 310  
Islandia, NY 11749

**Festo Customer Interaction Center**  
1 800 993 3786  
1 800 963 3786  
[customer.service.us@festo.com](mailto:customer.service.us@festo.com)



**4 Regional Service Center**  
7777 Columbia Road  
Mason, OH 45040

Connect with us



[www.festo.com/socialmedia](http://www.festo.com/socialmedia)



[www.festo.com](http://www.festo.com)

Subject to change