

## Angle grippers DHWS

**FESTO**



## Key features

### At a glance

#### General information

- Improved gripper jaw guide
- Slotted guide
- Max. repetition accuracy
- Gripping force retention
- Internal fixed flow control
- Wide range of adaptation options on the drives

- Sensor technology:
  - Adaptable position sensor for the small gripper sizes
  - Integrated proximity sensors for the medium and large gripper sizes

#### Flexible range of applications

- Can be used as a double-acting and single-acting gripper
- Compression spring for supplementing or retaining the gripping forces
- Suitable for external and internal gripping

### The technology in detail

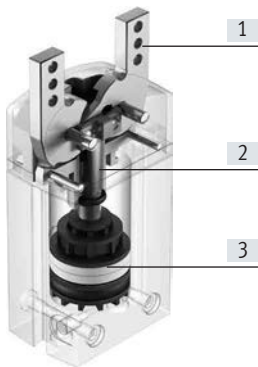

- [1] Gripper jaws
- [2] Link
- [3] Piston with magnet

#### Note

Engineering software for gripper selection  
→ [www.festo.com](http://www.festo.com)

### Position sensing/force control

#### With position transmitter SMAT-8M/SDAT



Analogue position feedback possible

- Analogue output
  - 0 ... 10 V
  - 4 ... 20 mA

#### With proportional pressure regulator VPPM



Infinite adjustment of the gripping force possible

- Setpoint input
  - 0 ... 10 V
  - 4 ... 20 mA

#### With proximity sensor SMT-8G/-10G



Detecting multiple positions:

- Open
- Closed
- Workpiece gripped

## Key features

### Supply ports

From the side

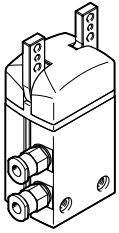

### Mounting options

From the side

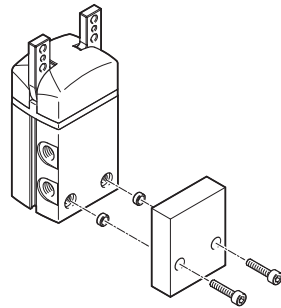
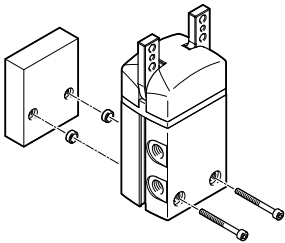

From underneath

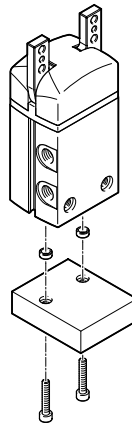

### Mounting options for external gripper fingers

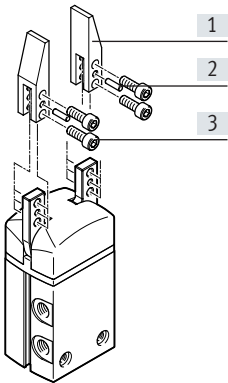

- [1] Gripper fingers
- [2] Centring pins
- [3] Retaining screws

### Note

Angle grippers are not designed for the following application examples:

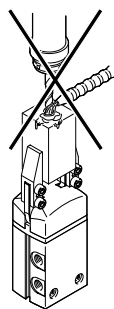

- Machining
- Aggressive media

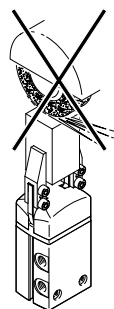

- Grinding dust

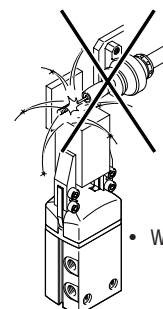

- Welding spatter

## Peripherals overview

### Peripherals overview

DHWS-10

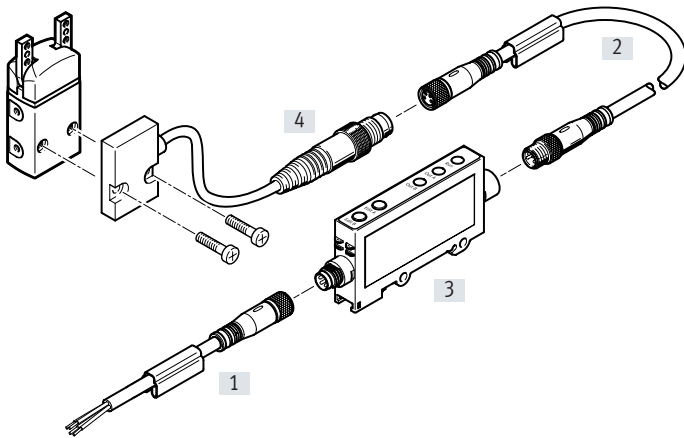

DHWS-16 ... 40

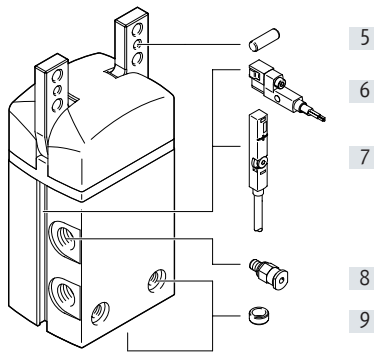

### System product for handling and assembly technology

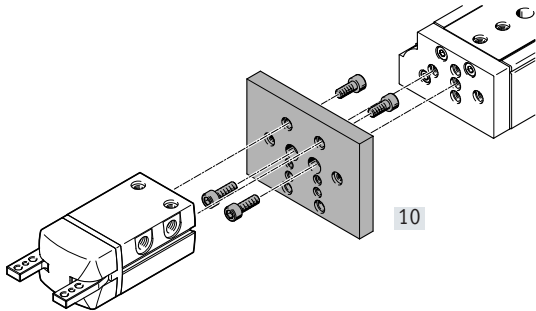

### Proportional-pressure regulator VPPM

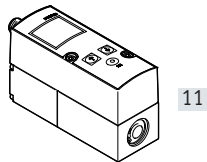

## Peripherals overview

| Accessories                                      |           |  |                 |
|--|-----------|--|-----------------|
| Type   | For size  | Description  | → Page/Internet |
| [1] Connecting cable<br>NEBU                     | 10        | • Connection between signal converter and controller   | 19              |
| [2] Connecting cable<br>NEBU                     | 10        | • Connection between position sensor and signal converter  | 19              |
| [3] Signal converter<br>SVE4                     | 10        | • For evaluating signals for position sensor SMH-S1  | 19              |
| [4] Position sensor<br>SMH-S1                    | 10        | • Adaptable and integratable sensor technology for sensing the piston position   | 19              |
| [5] Centring pin                                 | 10 ... 40 | • For centring the gripper fingers on the gripper jaws   | –               |
| [6] Proximity sensor<br>SMT-8G                   | 16 ... 40 | • For sensing the piston position<br>• Proximity sensor does not project past the housing at the bottom                            | 20              |
| [7] Position transmitter<br>SMAT-8M              | 16 ... 40 | • Continuously senses the position of the piston. It has an analogue output with an output signal relative to the piston position. | 20              |
| Position transmitter<br>SDAT                     | 32, 40    |  |                 |
| [8] Push-in fitting<br>QS                        | 10 ... 40 | • For connecting compressed air tubing with standard O.D.  | qs              |
| [9] Centring sleeve<br>ZBH                       | 10 ... 40 | • For centring the gripper during mounting<br>• 2 centring sleeves included in the scope of delivery of the gripper                | 19              |
| [10] Adapter kit<br>DHAA, HMSV, HAPG, HAPS, HMVA | 10 ... 40 | • Connecting plate between drive and gripper   | 16              |
| [11] Proportional-pressure regulator<br>VPPM     | 10 ... 40 | • For infinite adjustment of the gripping force  | vppm            |

## Type codes

| 001         | Series        |  |
|-------------|---------------|--|
| <b>DHWS</b> | Angle gripper |  |

| 002       | Size |  |
|-----------|------|--|
| <b>10</b> | 10   |  |
| <b>16</b> | 16   |  |
| <b>25</b> | 25   |  |
| <b>32</b> | 32   |  |
| <b>40</b> | 40   |  |

| 003      | Position sensing     |  |
|----------|----------------------|--|
| <b>A</b> | For proximity sensor |  |

| 004       | Gripping force backup |  |
|-----------|-----------------------|--|
|           | None                  |  |
| <b>NC</b> | N/O contact           |  |

## Data sheet

-  Size  
10 ... 40 mm
-  Opening angle  
40°
-  www.festo.com

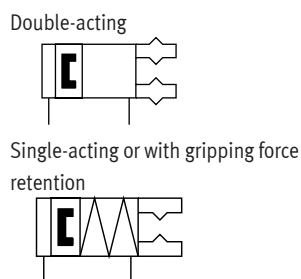

| General technical data            |      | 10                                    | 16 | 25   | 32   | 40   |
|-----------------------------------|------|---------------------------------------|----|--|------|------|
| Size                              |      | 10                                    | 16 | 25   | 32   | 40   |
| Design                            |      | Lever                                 |    |  |      |      |
| Mode of operation                 |      | Double-acting                         |    |  |      |      |
| Gripper function                  |      | Angular                               |    |  |      |      |
| Guide                             |      | Plain-bearing guide                   |    |  |      |      |
| Gripping force retention          |      | –                                     | NC | NC   | NC   | NC   |
| Number of gripper jaws            |      | 2                                     |    |  |      |      |
| Opening angle per gripper jaw     | [°]  | 20                                    |    |  |      |      |
| Pneumatic connection              |      | M3                                    | M3 | M5   | G1/8 | G1/8 |
| Repetition accuracy <sup>1)</sup> | [mm] | ≤ 0.04                                |    |  |      |      |
| Max. interchangeability           | [mm] | ≤ ±0.2                                |    |  |      |      |
| Max. operating frequency          | [Hz] | 4                                     |    | 3  |      |      |
| Rotational symmetry               | [mm] | < ∅ 0.2                               |    |  |      |      |
| Position sensing                  |      | Via position sensor                   |    | Via proximity sensor, position transmitter |      |      |
| Type of mounting                  |      | Via through-hole and centring sleeve  |    |  |      |      |
|                                   |      | Via female thread and centring sleeve |    |  |      |      |
| Mounting position                 |      | Any                                   |    |  |      |      |

1) Under constant exposure to operating conditions, end-position drift occurs in the direction of movement of the gripper jaws, at 100 consecutive strokes

| Operating and environmental conditions       |       | 10   | 16 | 25 | 32 | 40 |
|--|-------|--|----|----|----|----|
| Size   |       | 10   | 16 | 25 | 32 | 40 |
| Min. operating pressure                      |       |  |    |    |    |    |
| DHWS-...-A                                   | [bar] | 2  |    |    |    |    |
| DHWS-...-A-NC                                | [bar] | –  | 4  |    |    |    |
| Max. operating pressure                      | [bar] | 8  |    |    |    |    |
| Operating medium                             |       | Compressed air to ISO 8573-1:2010 [7:4:4]  |    |    |    |    |
| Note on operating/pilot medium               |       | Lubricated operation possible (in which case lubricated operation will always be required) |    |    |    |    |
| Ambient temperature <sup>1)</sup>            | [°C]  | +5 ... +60   |    |    |    |    |
| Corrosion resistance class CRC <sup>2)</sup> |       | 1  |    |    |    |    |

1) Note operating range of proximity sensors

2) Corrosion resistance class CRC 1 to Festo standard FN 940070

Low corrosion stress. Dry indoor application or transport and storage protection. Also applies to parts behind coverings, in the non-visible interior area, and parts which are covered in the application (e.g. drive trunnions).

| Weight [g]    |  | 10 | 16  | 25  | 32  | 40  |
|---------------|--|----|-----|-----|-----|-----|
| Size          |  | 10 | 16  | 25  | 32  | 40  |
| DHWS-...-A    |  | 40 | 110 | 258 | 452 | 775 |
| DHWS-...-A-NC |  | –  | 114 | 265 | 462 | 790 |

Data sheet

Materials

Sectional view

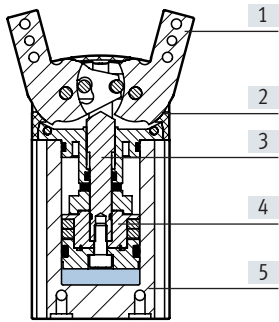

| Angle gripper       |                                       |
|---------------------|---------------------------------------|
| [1] Gripper jaws    | High-alloy stainless steel            |
| [2] Cover cap       | Polyamide                             |
| [3] Link            | Tempered steel                        |
| [4] Piston          | Polyacetal                            |
| [5] Housing         | Hard anodised wrought aluminium alloy |
| - Seals             | Nitrile rubber                        |
| - Note on materials | Free of copper and PTFE               |
|                     | RoHS-compliant                        |

Total gripping torque [Ncm] at 6 bar

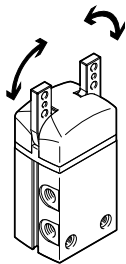

| Size       |         | 10 | 16  | 25  | 32  | 40   |
|------------|---------|----|-----|-----|-----|------|
| DHWS-...-A | Opening | 43 | 129 | 386 | 810 | 1497 |
|            | Closing | 30 | 114 | 356 | 746 | 1362 |

Static characteristic load values at the gripper jaws

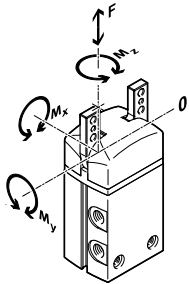

The indicated permissible forces and torques apply to a single gripper jaw. They include the lever arm, additional weight forces created by the workpiece or external gripper fingers and acceleration forces during movement. The zero coordinate line (gripper jaw guide) must be taken into consideration when calculating torques.

| Size                          |      | 10  | 16  | 25  | 32  | 40  |
|-------------------------------|------|-----|-----|-----|-----|-----|
| Max. permissible force $F_z$  | [N]  | 25  | 50  | 90  | 120 | 200 |
| Max. permissible torque $M_x$ | [Nm] | 0.6 | 1.6 | 3.6 | 6   | 13  |
| Max. permissible torque $M_y$ | [Nm] | 0.6 | 1.6 | 3.6 | 6   | 13  |
| Max. permissible torque $M_z$ | [Nm] | 0.6 | 1.6 | 3.6 | 6   | 13  |

Mass moments of inertia [ $\text{kgm}^2 \times 10^{-4}$ ]

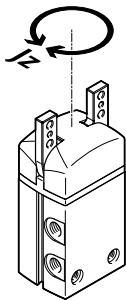

Mass moment of inertia of the angle gripper in relation to the central axis, without external gripper fingers, without load.

| Size          |  | 10   | 16   | 25   | 32   | 40   |
|---------------|--|------|------|------|------|------|
| DHWS-...-A    |  | 0.03 | 0.14 | 0.62 | 1.60 | 3.81 |
| DHWS-...-A-NC |  | -    | 0.15 | 0.64 | 1.63 | 3.87 |



Data sheet

Opening and closing times [ms] at 6 bar

Without external gripper fingers

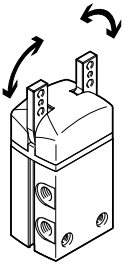

The indicated opening and closing times [ms] were measured at room temperature at an operating pressure of 6 bar with the gripper horizontally mounted and without additional gripper fingers (mean values shown). The grippers must be throttled for greater applied loads. Opening and closing times must then be adjusted accordingly.

| Size                                    |         | 10 | 16 | 25  | 32 | 40 |
|---|---------|----|----|-----|----|----|
| <b>Without external gripper fingers</b> |         |    |    |     |    |    |
| DHWS-...-A                              | Opening | 10 | 44 | 64  | 46 | 63 |
|   | Closing | 22 | 52 | 80  | 77 | 96 |
| DHWS-...-A-NC                           | Opening | -  | 62 | 106 | 88 | 99 |
|   | Closing | -  | 36 | 59  | 55 | 69 |

Opening and closing times  $t$  to be set at 6 bar as a function of mass moment of inertia of the gripper fingers

DHWS-10

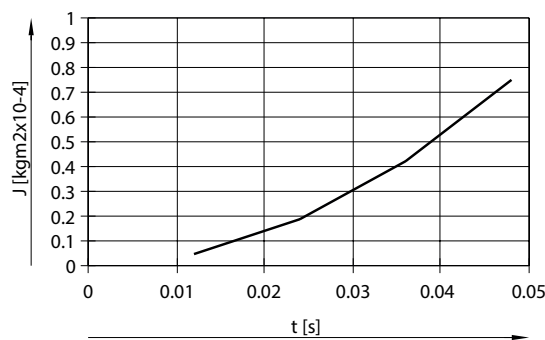

DHWS-16

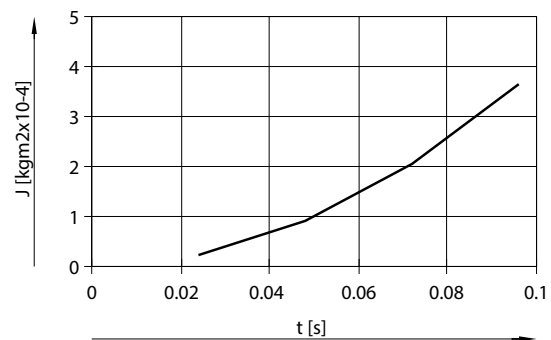

DHWS-25

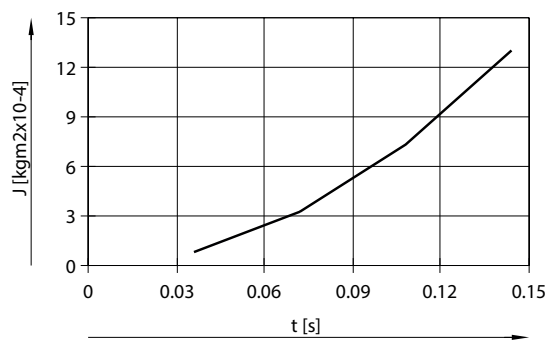

DHWS-32

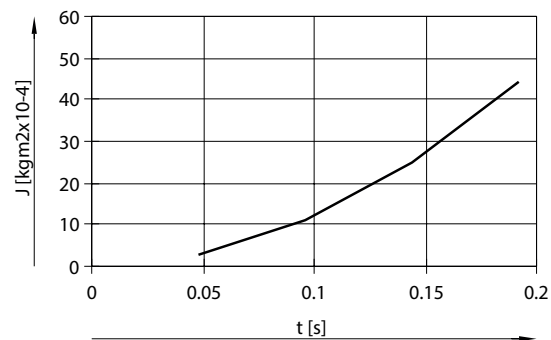

DHWS-40

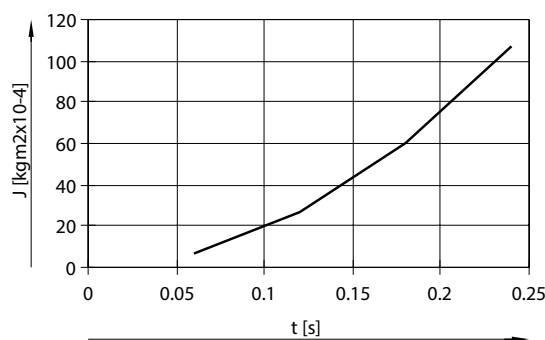

Data sheet

Gripping force  $F_H$  per gripper jaw as a function of operating pressure and lever arm  $x$

The gripping forces as a function of the operating pressure and lever arm can be determined from the following graphs.

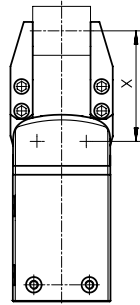

 **Note**  
Engineering software  
for gripper selection  
→ [www.festo.com](http://www.festo.com)

- 2 bar
- · - · - 4 bar
- - - - - 6 bar
- · · · · 8 bar

External gripping (closing)

DHWS-10

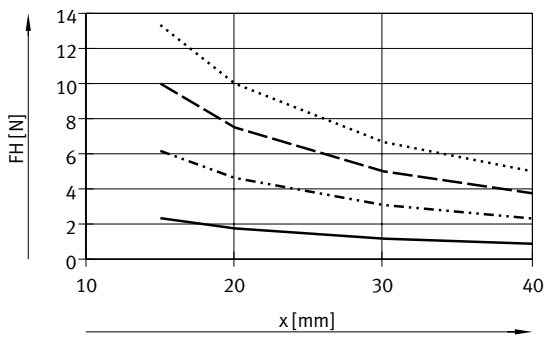

DHWS-16

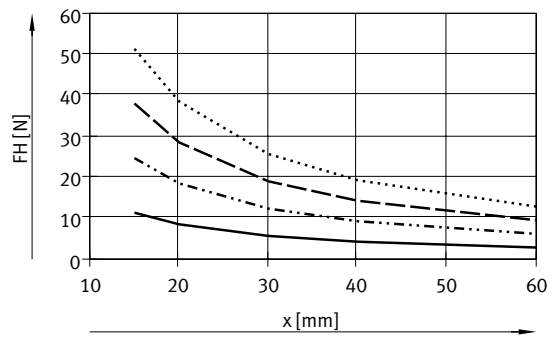

DHWS-25

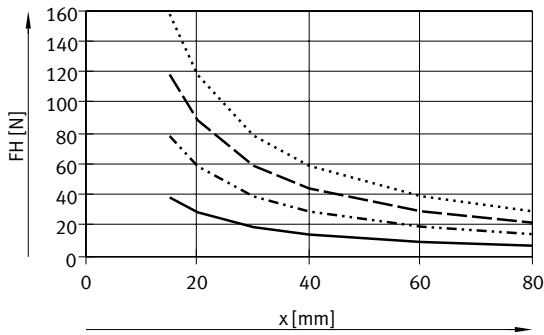

DHWS-32

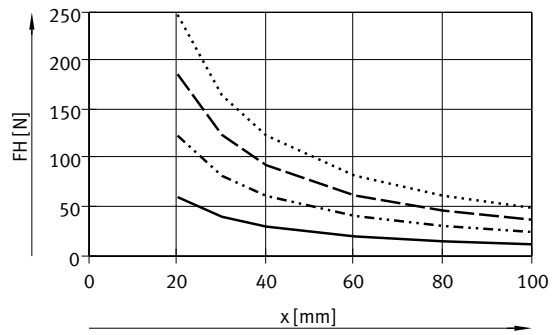

DHWS-40

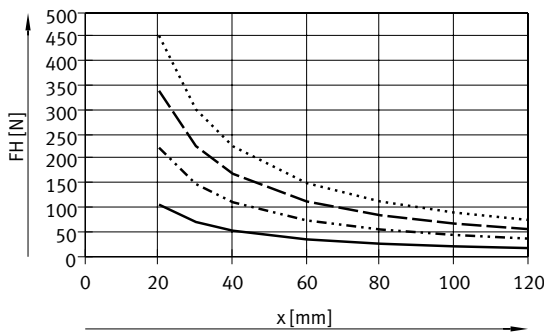

## Data sheet

### Gripping force $F_H$ per gripper jaw as a function of operating pressure and lever arm $x$

The gripping forces as a function of the operating pressure and lever arm can be determined from the following graphs.

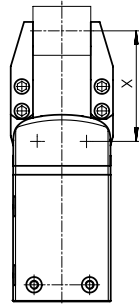

**Note**  
Engineering software  
for gripper selection  
→ [www.festo.com](http://www.festo.com)

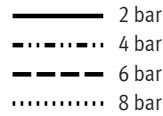

### Internal gripping (opening)

DHWS-10

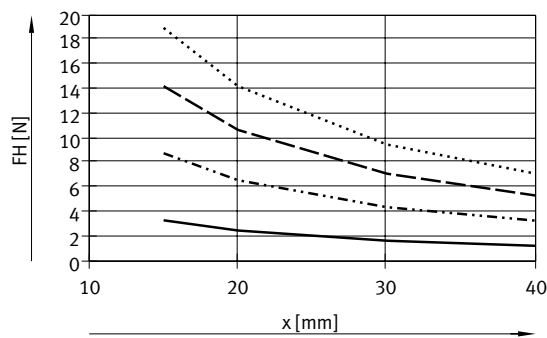

DHWS-16

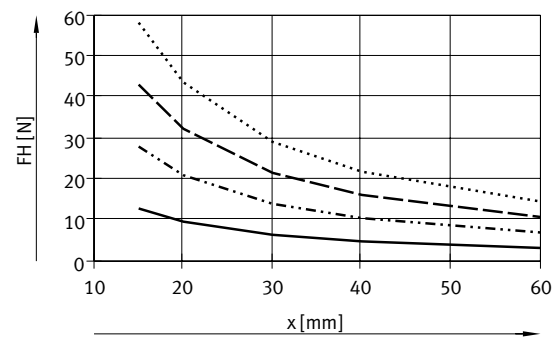

DHWS-25

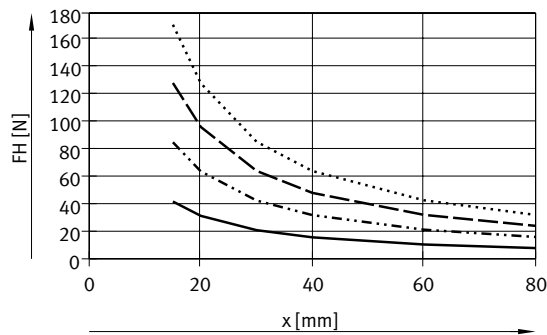

DHWS-32

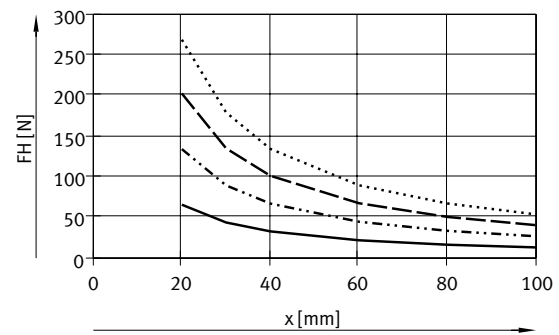

DHWS-40

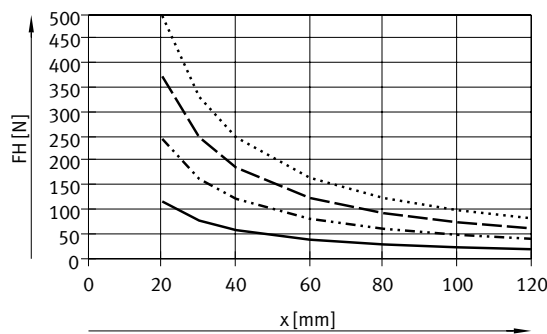

## Data sheet

### Gripping force $F_H$ per gripper jaw at 6 bar as a function of lever arm $x$ and eccentricity $a$ and $b$

The following formula must be used to calculate the lever arm  $x$  with eccentric gripping:

$$x = \sqrt{a^2 + b^2}$$

The gripping force  $F_H$  can be read from the graphs (→ page 10) using the calculated value  $x$ .

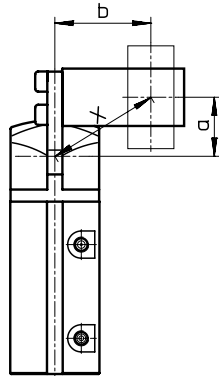

### Calculation example

Given:

Distance  $a = 20$  mm

Distance  $b = 25$  mm

To be calculated:

The gripping force at 6 bar

with a DHWS-16,

used as an external gripper

Procedure: calculating the lever arm  $x$

$$x = \sqrt{20^2 + 25^2}$$

$$x = 32$$
 mm

The graph (→ page 10) gives a value of  $F_H = 18$  N for the gripping force.

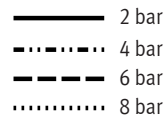
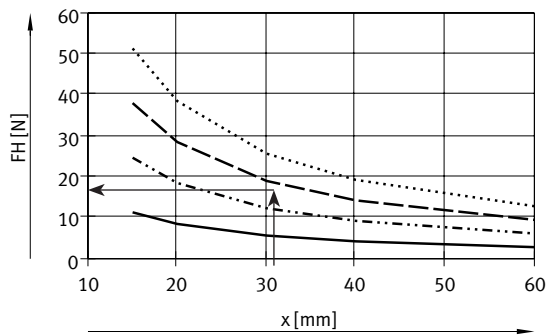

Data sheet

Spring torque  $M_F$  as a function of opening angle  $\alpha$

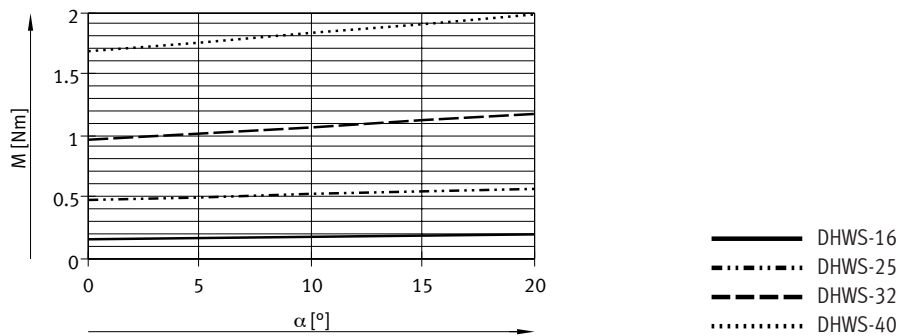

Determining the actual gripping torques  $M_{Grtotal}$  for DHWS-...-NC as a function of application

The angle gripper with integrated spring type DHWS-...-NC (closing gripping force retention) can be used as:

- Single-acting gripper
- Gripper with supplementary gripping force
- Gripper with gripping force retention

To calculate the available gripping torque  $M_{Grtotal}$  (per gripper jaw), the data from the graphs for the gripping force  $F_H$  (→ page 10) and the spring torque  $M_F$  (→ page 13) must be combined accordingly.

$$M_{Gr} = F_H \cdot x$$

- $M_{Gr}$  Gripping torque
- $F_H$  Gripping force
- $x$  Lever arm

Application

| Single-acting   | Supplementary gripping force   | Gripping force retention   |
|---|--|--|
| <ul style="list-style-type: none"> <li>• Gripping with spring force:<br/><math>M_{Grtotal} = M_F</math></li> <li>• Gripping with pressure force:<br/><math>M_{Grtotal} = M_{Gr} - M_F</math></li> </ul> | <ul style="list-style-type: none"> <li>• Gripping with pressure and spring force:<br/><math>M_{Grtotal} = M_{Gr} + M_F</math></li> </ul> | <ul style="list-style-type: none"> <li>• Gripping with spring force:<br/><math>M_{Grtotal} = M_F</math></li> </ul> |

Data sheet

Dimensions

Download CAD data → [www.festo.com](http://www.festo.com)

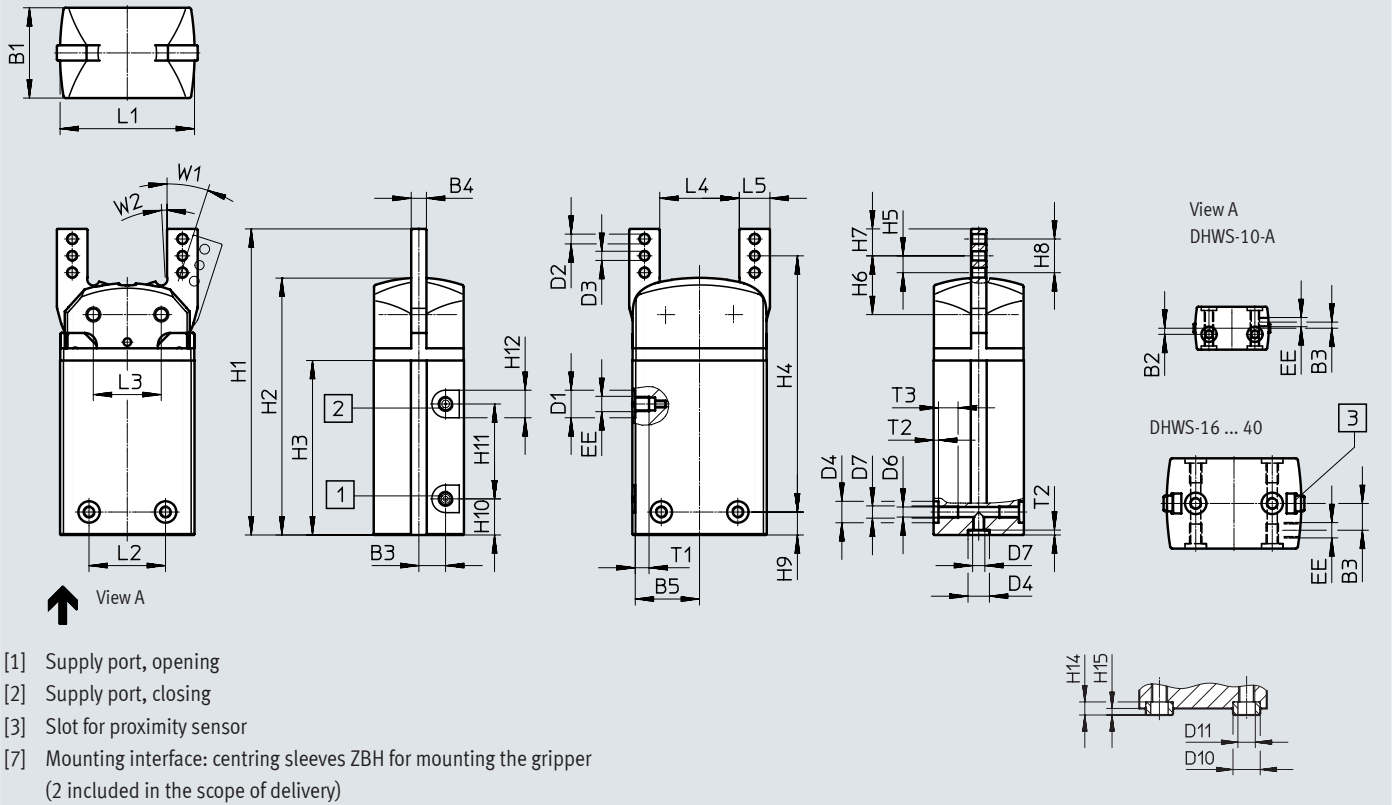

- [1] Supply port, opening
- [2] Supply port, closing
- [3] Slot for proximity sensor
- [7] Mounting interface: centring sleeves ZBH for mounting the gripper (2 included in the scope of delivery)

| Size | B1    | B2 <sup>1)</sup> | B3   | B4              | B5   | D1 | D2        | D3      | D4         | D6        | D7 |
|------|-------|------------------|------|-----------------|------|----|-----------|---------|------------|-----------|----|
| [mm] | ±0.05 |                  |      | -0.03/<br>-0.05 |      | ∅  | ∅<br>±0.1 | ∅<br>H8 | ∅<br>H8/h7 | ∅<br>+0.1 |    |
| 10   | 14    | 2                | 2    | 3               | 11.6 | 7  | 2.2       | 2       | 5          | 2.4       | M3 |
| 16   | 19    | -                | 5.8  | 4               | 16   | -  | 3.2       | 2.5     | 5          | 2.5       | M3 |
| 25   | 29.5  | -                | 8.75 | 5               | 21   | 9  | 3.2       | 3       | 7          | 3.3       | M4 |
| 32   | 38    | -                | 11   | 6               | 24   | 15 | 4.3       | 3       | 9          | 5.1       | M6 |
| 40   | 49    | -                | 11   | 8               | 28.4 | 15 | 5.3       | 4       | 12         | 6.4       | M8 |

| Size | D10     | D11  | EE   | H1   | H2    | H3   | H4    | H5  | H6    | H7   |
|------|---------|------|------|------|-------|------|-------|-----|-------|------|
| [mm] | ∅<br>h7 | ∅    |      |      |       |      | ±0.2  |     | ±0.05 |      |
| 10   | 5       | 3.2  | M3   | 56.3 | 46    | 30.8 | 38.25 | 3.5 | 10.95 | 5.75 |
| 16   | 5       | 3.2  | M3   | 81   | 67    | 45.5 | 66    | 4.5 | 15.5  | 7.5  |
| 25   | 7       | 5.3  | M5   | 100  | 84    | 57   | 83.7  | 5.5 | 19.2  | 8.8  |
| 32   | 9       | 6.4  | G1/8 | 116  | 96.2  | 65   | 100.5 | 6.5 | 22.5  | 11   |
| 40   | 12      | 10.3 | G1/8 | 129  | 108.4 | 71.5 | 99.5  | 7   | 24.5  | 12   |

1) Tolerance for centring hole ±0.02 mm; tolerance for thread ±0.1 mm

## Data sheet

| Size | H8 | H9 <sup>2)</sup> | H10   | H11 | H12 | H14  | H15  | L1    | L2 <sup>1)</sup> |
|------|----|------------------|-------|-----|-----|------|------|-------|------------------|
| [mm] |    |                  |       |     |     | -0.2 | -0.3 | ±0.05 |                  |
| 10   | 7  | 12.3             | 8.8   | 16  | 7   | 2.4  | 1.2  | 24    | 15               |
| 16   | 9  | 7.5              | 12.25 | 23  | 7   | 2.4  | 1.2  | 34    | 16               |
| 25   | 11 | 7.5              | 11.8  | 31  | 9   | 3    | 1.4  | 44    | 25               |
| 32   | 13 | 11               | 20    | 25  | 15  | 4    | 1.9  | 53    | 29               |
| 40   | 14 | 17.5             | 9     | 46  | 15  | 5    | 2.4  | 59    | 33               |

| Size | L3    | L4 | L5              | T1   | T2   | T3      | W1      | W2  |
|------|-------|----|-----------------|------|------|---------|---------|-----|
| [mm] | ±0.02 |    | -0.02/<br>-0.05 | +0.5 | +0.1 | +1      | +3°/-1° | ±1° |
| 10   | 12.4  | 14 | 5.5             | 3.5  | 1.2  | through | 18      | 3   |
| 16   | 17    | 18 | 8               | 4.5  | 1.2  | 5.8     | 18      | 3   |
| 25   | 22.2  | 26 | 10              | 4.5  | 1.6  | 6.4     | 18      | 3   |
| 32   | 25.8  | 29 | 12              | 7.5  | 2.1  | 12.9    | 18      | 3   |
| 40   | 30    | 32 | 15              | 6    | 2.6  | 13.4    | 18      | 3   |

1) Tolerance for centring hole ±0.02 mm; tolerance for thread ±0.1 mm

2) Tolerance for centring hole -0.05 mm; tolerance for thread ±0.1 mm

## Ordering data

| Size | Double-acting<br>without compression spring |           | Single-acting or with gripping force retention<br>closing |              |
|------|---|-----------|---|--------------|
|      | Part no.                                    | Type      | Part no.  | Type         |
| [mm] |   |           |   |              |
| 10   | 1310177                                     | DHWS-10-A | -   |              |
| 16   | 1310178                                     | DHWS-16-A | 1310179   | DHWS-16-A-NC |
| 25   | 1310180                                     | DHWS-25-A | 1310181   | DHWS-25-A-NC |
| 32   | 1310182                                     | DHWS-32-A | 1310183   | DHWS-32-A-NC |
| 40   | 1310184                                     | DHWS-40-A | 1310185   | DHWS-40-A-NC |

Accessories



Adapter kit  
HAPG, HAPS, HMSV

Material:  
Wrought aluminium alloy  
Free of copper and PTFE  
RoHS-compliant

 **Note**  
The kit includes the individual mounting interface as well as the necessary mounting material.

Permissible drive/gripper combinations with adapter kit

Download CAD data → [www.festo.com](http://www.festo.com)

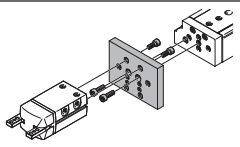
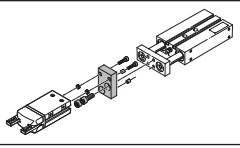
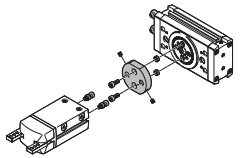
| Combination  | Drive<br>Size | Gripper<br>Size | Mounting option   |   | Adapter kit       |          |                           |
|--|---------------|-----------------|---|---|-------------------|----------|---------------------------|
|  |               |                 |  |  | CRC <sup>1)</sup> | Part no. | Type                      |
| <b>DGSL/DHWS</b>   | <b>DGSL</b>   | <b>DHWS</b>     |   |   | <b>HMSV</b>       |          |                           |
|    | 8, 10         | 10              | ■   | ■   | 2                 | 548784   | HMSV-54                   |
|  | 12, 16        | 16              | ■   | ■   |                   | 548785   | HMSV-55                   |
|  | 20, 25        | 25, 32          | ■   | ■   |                   | 548786   | HMSV-56                   |
| <b>DPZ/DHWS</b>  | <b>DPZ</b>    | <b>DHWS</b>     |   |   | <b>HAPG</b>       |          |                           |
|   | 10, 16        | 16              | ■   | –   | 2                 | 163250   | HAPG-1                    |
|  | 16            | 25              | ■   | –   |                   | 163251   | HAPG-2                    |
|  | 20            | 25              | ■   | –   |                   | 163252   | HAPG-3                    |
|  | 25, 32        | 32              | ■   | –   |                   | 163253   | HAPG-4                    |
| <b>DRRD/DHWS</b>   | <b>DRRD</b>   | <b>DHWS</b>     |   |   | <b>DHAA</b>       |          |                           |
|  | 8             | 10              | ■   | ■   | 2                 | 2816591  | DHAA-G-Q11-8-B2/B3-10     |
|  | 10            | 10              | ■   | ■   |                   | 2816068  | DHAA-G-Q11-10-B2/B3-10    |
|  | 12            | 10              | ■   | ■   |                   | 2814790  | DHAA-G-Q11-12-B2/B3-10    |
|  | 12            | 16              | ■   | ■   |                   | 2811183  | DHAA-G-Q11-12-B2/B3-16    |
|  | 16            | 16              | ■   | ■   |                   | 1979085  | DHAA-G-Q11-16-B2/B3-16    |
|  | 16            | 25              | ■   | ■   |                   | 1978889  | DHAA-G-Q11-16-B2/B3-25    |
|  | 20            | 25              | ■   | ■   |                   | 1978443  | DHAA-G-Q11-20-B2/B3-25    |
|  | 20            | 32              | ■   | ■   |                   | 1979912  | DHAA-G-Q11-20-B2/B3-32    |
|  | 25            | 25              | ■   | ■   |                   | 1801802  | DHAA-G-Q11-25-B2/B3-25    |
|  | 25            | 32              | ■   | ■   |                   | 1802969  | DHAA-G-Q11-25-B2/B3-32    |
|  | 32            | 32              | ■   | ■   |                   | 1979992  | DHAA-G-Q11-32-B2/B3-32    |
|  | 32            | 40              | ■   | ■   |                   | 1980014  | DHAA-G-Q11-32-B2/B3-40    |
|  | 35, 40        | 40              | ■   | ■   |                   | 1980059  | DHAA-G-Q11-35/40-B2/B3-40 |

1) Corrosion resistance class CRC 2 to Festo standard FN 940070

Moderate corrosion stress. Indoor applications in which condensation can occur. External visible parts with primarily decorative surface requirements which are in direct contact with a normal industrial environment.



## Accessories



### Adapter kit DHAA, HAPG

Material:  
Wrought aluminium alloy  
Free of copper and PTFE  
RoHS-compliant



**Note**

The kit includes the individual mounting interface as well as the necessary mounting material.

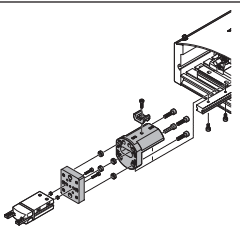
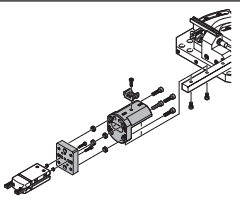
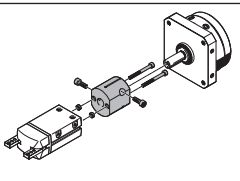
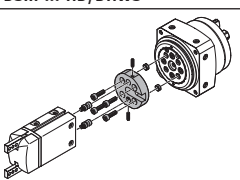
| Permissible drive/gripper combinations with adapter kit                             |                   |                 |   |   |                                  | Download CAD data → <a href="http://www.festo.com">www.festo.com</a> |                     |
|---|-------------------|-----------------|---|---|----------------------------------|--|---------------------|
| Combination   | Drive<br>Size     | Gripper<br>Size | Mounting option   |   | Adapter kit<br>CRC <sup>1)</sup> | Part no.   | Type                |
|   |                   |                 |  |  |                                  |  |                     |
|    | <b>HSP</b>        | <b>DHWS</b>     |   |   | <b>HAPG</b>                      |  |                     |
|   | 12                | 10              | ■   | –   | 2                                | 192709   | HAPG-60-S1          |
|   |                   |                 |   |   |                                  | 540881   | HAPG-70-B           |
|   | 16                | 10              | ■   | –   |                                  | 192706   | HAPG-37-S1          |
|   |                   |                 |   |   |                                  | 540882   | HAPG-71-B           |
|   | 16                | 16              | ■   | –   |                                  | 192705   | HAPG-36-S1          |
|   |                   |                 |   |   |                                  | 540882   | HAPG-71-B           |
| 25  | 16                | ■               | –   |   | 192705                           | HAPG-36-S1   |                     |
|   |                   |                 |   |   | 540883                           | HAPG-72-B  |                     |
| 25  | 25                | ■               | –   |   | 193922                           | HAPG-37-S4   |                     |
|   |                   |                 |   |   | 540883                           | HAPG-72-B  |                     |
|   | <b>HSW</b>        | <b>DHWS</b>     |   |   | <b>HAPG</b>                      |  |                     |
|   | 12, 16            | 10              | ■   | –   | 2                                | 192706   | HAPG-37-S1          |
|   |                   |                 |   |   |                                  | 540882   | HAPG-71-B           |
|   | 12, 16            | 16              | ■   | –   |                                  | 192705   | HAPG-36-S1          |
|   |                   |                 |   |   | 540882                           | HAPG-71-B  |                     |
|  | <b>DSM-...-FW</b> | <b>DHWS</b>     |   |   | <b>HAPG</b>                      |  |                     |
|   | 6, 8, 10          | 10              | ■   | ■   | 2                                | 187568   | HAPG-34             |
|   | <b>DSM-...</b>    | <b>DHWS</b>     |   |   | <b>HAPG</b>                      |  |                     |
|   | 12                | 16              | ■   | ■   | 2                                | 163266   | HAPG-17             |
|   | 16                | 16              | ■   | ■   |                                  | 163267   | HAPG-18             |
|   | 16                | 25              | ■   | ■   |                                  | 163268   | HAPG-19             |
|   | 25                | 25              | ■   | ■   |                                  | 163269   | HAPG-20             |
|   | 25                | 32              | ■   | ■   |                                  | 163270   | HAPG-21             |
| 32  | 32                | ■               | ■   |   | 163271                           | HAPG-22  |                     |
|  | <b>DSM-...-HD</b> | <b>DHWS</b>     |   |   | <b>DHAA</b>                      |  |                     |
|   | 12                | 16              | ■   | ■   | 2                                | 8072157  | DHAA-G-R3-12-B18-10 |
|   | 12                | 10              | ■   | ■   |                                  | 8072172  | DHAA-G-R3-12-B20-10 |
|   | 16                | 16              | ■   | ■   |                                  | 8071917  | DHAA-G-R3-16-B18-10 |
|   | 16                | 25              | ■   | ■   |                                  | 8079173  | DHAA-G-R3-16-B18-16 |
|   | 25                | 25              | ■   | ■   |                                  | 8071956  | DHAA-G-R3-25-B18-16 |
|   | 25                | 32              | ■   | ■   |                                  | 8079201  | DHAA-G-R3-25-B20-32 |
|   | 32                | 32              | ■   | ■   |                                  | 8079208  | DHAA-G-R3-32-B18-25 |
|   | 32                | 40              | ■   | ■   |                                  | 8079212  | DHAA-G-R3-32-B20-40 |

1) Corrosion resistance class CRC 2 to Festo standard FN 940070

Moderate corrosion stress. Indoor applications in which condensation can occur. External visible parts with primarily decorative surface requirements which are in direct contact with a normal industrial environment.

Accessories



Adapter kit  
DHAA, HAPG, HMSV

Material:  
Wrought aluminium alloy  
Free of copper and PTFE  
RoHS-compliant

 **Note**  
The kit includes the individual mounting interface as well as the necessary mounting material.

Permissible drive/gripper combinations with adapter kit

Download CAD data → [www.festo.com](http://www.festo.com)

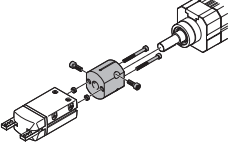
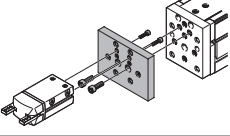
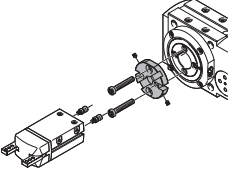
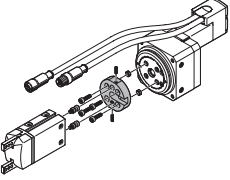
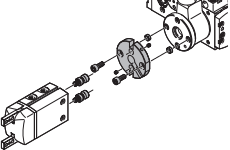
| Combination  | Drive Size  | Gripper Size | Mounting option   |   | Adapter kit CRC <sup>1)</sup> | Part no. | Type                |
|--|-------------|--------------|---|---|-------------------------------|----------|---------------------|
|  |             |              |  |  |                               |          |                     |
| <b>DSL/DHWS</b>  | <b>DSL</b>  | <b>DHWS</b>  |   |   | <b>HAPG</b>                   |          |                     |
|    | 16          | 16           | ■   | ■   | 2                             | 163266   | HAPG-17             |
|  | 20          | 16           | ■   | ■   |                               | 163267   | HAPG-18             |
|  | 20          | 25           | ■   | ■   |                               | 163268   | HAPG-19             |
|  | 25          | 25           | ■   | ■   |                               | 163269   | HAPG-20             |
|  | 25          | 32           | ■   | ■   |                               | 163270   | HAPG-21             |
|  | 32          | 32           | ■   | ■   |                               | 163271   | HAPG-22             |
| <b>EGSL/DHWS</b>   | <b>EGSL</b> | <b>DHWS</b>  |   |   | <b>HMSV</b>                   |          |                     |
|   | 35          | 10           | ■   | ■   | 2                             | 548784   | HMSV-54             |
|  | 45, 55      | 16           | ■   | ■   |                               | 1088262  | HMSV-70             |
|  | 75          | 25, 32       | ■   | ■   |                               | 548785   | HMSV-55             |
|  |             |              |   |   |                               | 548786   | HMSV-56             |
| <b>ERMB/DHWS</b>   | <b>ERMB</b> | <b>DHWS</b>  |   |   | <b>HAPG</b>                   |          |                     |
|  | 20          | 25           | ■   | ■   | 2                             | 184479   | HAPG-SD2-3          |
|  | 25          | 25           | ■   | ■   |                               | 184482   | HAPG-SD2-6          |
|  | 20          | 32           | ■   | ■   |                               | 184480   | HAPG-SD2-4          |
|  | 25          | 32           | ■   | ■   |                               | 184483   | HAPG-SD2-7          |
|  | 32          | 32           | ■   | ■   |                               | 184485   | HAPG-SD2-9          |
|  | 32          | 40           | ■   | ■   |                               | 184486   | HAPG-SD2-10         |
| <b>ERMO/DHWS</b>   | <b>ERMO</b> | <b>DHWS</b>  |   |   | <b>DHAA</b>                   |          |                     |
|  | 12          | 16           | ■   | ■   | 2                             | 8072157  | DHAA-G-R3-12-B18-10 |
|  | 12          | 10           | ■   | ■   |                               | 8072172  | DHAA-G-R3-12-B20-10 |
|  | 16          | 16           | ■   | ■   |                               | 8071917  | DHAA-G-R3-16-B18-10 |
|  | 16          | 25           | ■   | ■   |                               | 8079173  | DHAA-G-R3-16-B18-16 |
|  | 25          | 25           | ■   | ■   |                               | 8071956  | DHAA-G-R3-25-B18-16 |
|  | 25          | 32           | ■   | ■   |                               | 8079201  | DHAA-G-R3-25-B20-32 |
|  | 32          | 32           | ■   | ■   |                               | 8079208  | DHAA-G-R3-32-B18-25 |
|  | 32          | 40           | ■   | ■   |                               | 8079212  | DHAA-G-R3-32-B20-40 |
| <b>EHMB/DHWS</b>   | <b>EHMB</b> | <b>DHWS</b>  |   |   | <b>HAPG</b>                   |          |                     |
|  | 20          | 32           | ■   | ■   | 2                             | 184485   | HAPG-SD2-9          |
|  | 20          | 40           | ■   | ■   |                               | 184486   | HAPG-SD2-10         |
|  | 25, 32      | 40           | ■   | ■   |                               | 526027   | HAPG-SD2-21         |

1) Corrosion resistance class CRC 2 to Festo standard FN 940070

Moderate corrosion stress. Indoor applications in which condensation can occur. External visible parts with primarily decorative surface requirements which are in direct contact with a normal industrial environment.

## Accessories

| Ordering data  |               |  |            |               |               |                  |
|--|---------------|--|------------|---------------|---------------|------------------|
|  | For size [mm] | Description                              | Weight [g] | Part no.      | Type          | PU <sup>1)</sup> |
| Centring sleeve ZBH <span style="float: right;">Data sheets → Internet: zbh</span> |               |  |            |               |               |                  |
|   | 10, 16        | For centring the gripper during mounting | 1          | <b>189652</b> | <b>ZBH-5</b>  | 10               |
|  | 25            |  | 1          | <b>186717</b> | <b>ZBH-7</b>  |                  |
|  | 32            |  | 1          | <b>150927</b> | <b>ZBH-9</b>  |                  |
|  | 40            |  | 1          | <b>189653</b> | <b>ZBH-12</b> |                  |

1) Packaging unit

| Ordering data  |          |            |               |                     |
|--|----------|------------|---------------|---------------------|
| Type   | For size | Weight [g] | Part no.      | Type                |
| Position sensor SMH-S1 <span style="float: right;">Data sheets → Internet: smh-s1</span> |          |            |               |                     |
|         | 10       | 20         | <b>175711</b> | <b>SMH-S1-HGW10</b> |

### Signal converter SVE4 for position sensor SMH-S1

- Converts analogue signals into switching points
- Switching function freely programmable with teach-in
- Threshold value, hysteresis or window comparator

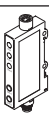
| Ordering data   |          |                    |                   |                  |            |               |                            |
|---|----------|--------------------|-------------------|------------------|------------|---------------|----------------------------|
| Type  | For size | Input connection   | Output connection | Switching output | Weight [g] | Part no.      | Type                       |
| Signal converter SVE4 <span style="float: right;">Data sheets → Internet: sve4</span> |          |                    |                   |                  |            |               |                            |
|    | 10       | Socket M8x1, 4-pin | Plug M8x1, 4-pin  | 2x PNP           | 19         | <b>544216</b> | <b>SVE4-HS-R-HM8-2P-M8</b> |
|   |          |                    |                   | 2x NPN           |            | <b>544219</b> | <b>SVE4-HS-R-HM8-2N-M8</b> |

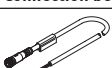
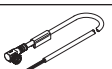
| Ordering data – Connecting cables   |                              |                              |                  |               |                             |
|---|------------------------------|------------------------------|------------------|---------------|-----------------------------|
|   | Electrical connection, left  | Electrical connection, right | Cable length [m] | Part no.      | Type                        |
| Connection between position sensor and signal converter                             |                              |                              |                  |               |                             |
|  | Straight socket, M8x1, 4-pin | Straight plug, M8x1, 4-pin   | 2.5              | <b>554035</b> | <b>NEBU-M8G4-K-2.5-M8G4</b> |
| Connection between signal converter and controller                                  |                              |                              |                  |               |                             |
|  | Straight socket, M8x1, 4-pin | Cable, open end, 4-wire      | 2.5              | <b>541342</b> | <b>NEBU-M8G4-K-2.5-LE4</b>  |
|   |                              |                              | 5                | <b>541343</b> | <b>NEBU-M8G4-K-5-LE4</b>    |
|  | Angled socket, M8x1, 4-pin   | Cable, open end, 4-wire      | 2.5              | <b>541344</b> | <b>NEBU-M8W4-K-2.5-LE4</b>  |
|   |                              |                              | 5                | <b>541345</b> | <b>NEBU-M8W4-K-5-LE4</b>    |

Accessories

Proximity sensor for size 16 ... 40

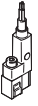

Ordering data – Proximity sensor for T-slot, magneto-resistive

Data sheets → Internet: smt

|  | Type of mounting                  | Electrical connection, outlet direction of connection | Switching output | Cable length [m] | Part no. | Type                     |
|--|-----------------------------------|---|------------------|------------------|----------|--------------------------|
| <b>N/O contact</b>   |                                   |   |                  |                  |          |                          |
|  | Insertable in the slot lengthwise | Cable, 3-wire, lateral                                | PNP              | 2.5              | 547859   | SMT-8G-PS-24V-E-2.5Q-OE  |
|  |                                   | Plug M8x1, 3-pin, lateral                             |                  | 0.3              | 547860   | SMT-8G-PS-24V-E-0.3Q-M8D |
|  |                                   | Cable, 3-wire, lateral                                | NPN              | 2.5              | 8065028  | SMT-8G-NS-24V-E-2.5Q-OE  |
|  |                                   | Plug M8x1, 3-pin, lateral                             |                  | 0.3              | 8065027  | SMT-8G-NS-24V-E-0.3Q-M8D |

Ordering data – Connecting cables

Data sheets → Internet: nebu

|  | Electrical connection, left  | Electrical connection, right | Cable length [m] | Part no. | Type                |
|--|------------------------------|------------------------------|------------------|----------|---------------------|
|  | Straight socket, M8x1, 3-pin | Cable, open end, 3-wire      | 2.5              | 541333   | NEBU-M8G3-K-2.5-LE3 |
|  |                              |                              | 5                | 541334   | NEBU-M8G3-K-5-LE3   |
|  | Angled socket, M8x1, 3-pin   | Cable, open end, 3-wire      | 2.5              | 541338   | NEBU-M8W3-K-2.5-LE3 |
|  |                              |                              | 5                | 541341   | NEBU-M8W3-K-5-LE3   |

Position transmitter

The position transmitter continuously senses the position of the piston.  
It has an analogue output with an output signal relative to the piston position.

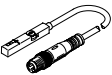
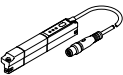

Ordering data – Position transmitter for T-slot

Data sheets → Internet: position transmitter

|  | For size  | Position measuring range | Analogue output [V]   [mA] |          | Type of mounting                  | Electrical connection     | Cable length [m] | Part no. | Type                        |
|--|-----------|--------------------------|----------------------------|----------|-----------------------------------|---------------------------|------------------|----------|-----------------------------|
|  | 16 ... 40 | 0 ... 40                 | 0 ... 10                   | –        | Insertable in the slot from above | Plug M8x1, 4-pin, in-line | 0.3              | 553744   | SMAT-8M-U-E-0.3-M8D         |
|  | 32, 40    | 0 ... 50                 | –                          | 4 ... 20 | Insertable in the slot from above | Plug M8x1, 4-pin, in-line | 0.3              | 1531265  | SDAT-MHS-M50-1L-SA-E-0.3-M8 |

Ordering data – Connecting cables

Data sheets → Internet: nebu

|  | Electrical connection, left  | Electrical connection, right | Cable length [m] | Part no. | Type                |
|--|------------------------------|------------------------------|------------------|----------|---------------------|
|  | Straight socket, M8x1, 4-pin | Cable, open end, 4-wire      | 2.5              | 541342   | NEBU-M8G4-K-2.5-LE4 |
|  |                              |                              | 5                | 541343   | NEBU-M8G4-K-5-LE4   |
|  | Angled socket, M8x1, 4-pin   | Cable, open end, 4-wire      | 2.5              | 541344   | NEBU-M8W4-K-2.5-LE4 |
|  |                              |                              | 5                | 541345   | NEBU-M8W4-K-5-LE4   |

# Festo - Your Partner in Automation



**1 Festo Inc.**  
5300 Explorer Drive  
Mississauga, ON L4W 5G4  
Canada

**Festo Customer Interaction Center**  
Tel: 1 877 463 3786  
Fax: 1 877 393 3786  
Email: [customer.service.ca@festo.com](mailto:customer.service.ca@festo.com)



**2 Festo Pneumatic**  
Av. Ceylán 3,  
Col. Tequesquináhuac  
54020 Tlalnepantla,  
Estado de México

**Multinational Contact Center**  
01 800 337 8669  
[ventas.mexico@festo.com](mailto:ventas.mexico@festo.com)



**3 Festo Corporation**  
1377 Motor Parkway  
Suite 310  
Islandia, NY 11749

**Festo Customer Interaction Center**  
1 800 993 3786  
1 800 963 3786  
[customer.service.us@festo.com](mailto:customer.service.us@festo.com)



**4 Regional Service Center**  
7777 Columbia Road  
Mason, OH 45040

Connect with us



[www.festo.com/socialmedia](http://www.festo.com/socialmedia)



[www.festo.com](http://www.festo.com)

Subject to change