



- Analogue and digital
- For measuring and positioning
- For use with pneumatic components

Displacement encoders

Key features

FESTO

Analogue displacement encoders

MLO-POT-...-TLF

- Conductive plastic potentiometer
- Absolute measurements with high resolution
- High speeds of travel and long service life
- Plug-in connections
- Stroke: 225 ... 2000 mm



MLO-POT-...-LWG

- Connecting rod potentiometer
- Absolute measurements with high resolution
- Long service life
- High degree of protection
- Plug-in connections
- Stroke: 100 ... 750 mm



Digital displacement encoders

MME-MTS-...-AIF

- Magnetostrictive measuring principle
- Contactless with absolute measurements
- High speeds of travel
- Long service life
- High degree of protection
- Several mounting options on pneumatic linear drives DGPL
- Plug-in connections
- Stroke: 225 ... 2000 mm



Displacement encoders

Selection aid

Recommended combinations of displacement encoder, drive and controller

Function	Version	Linear drive	Standard cylinder	End position controller		Axis controller		→ Page/ Internet
		DGC-K	DSBC	CPX-CMPX	SPC11	CPX-CMAX	CPX-CMIX	
Analogue	MLO-POT-TLF 	■	-	■	■	■	■	4
	MLO-POT-LWG 	-	■	■	■	■	■	6
Digital	MME-MTS-AIF 	■	-	■	■	■	■	8

Note
The displacement encoders can be combined with any linear drive provided that the installation conditions are adhered to and the customer uses the appropriate mounting.

Type code

MLO		-	POT		-	225		-	TLF	
Type										
MLO	Analogue displacement encoder									
MME	Digital displacement encoder									
Measuring principle										
POT	Potentiometric									
MTS	Magnetostrictive									
Stroke [mm]										
Version										
TLF	Profile									
LWG	Connecting rod									
AIF	Integrated AIF interface									

Displacement encoders MLO-POT, analogue

FESTO

Technical data

MLO-POT...-TLF

- Stroke length
225 ... 2000 mm

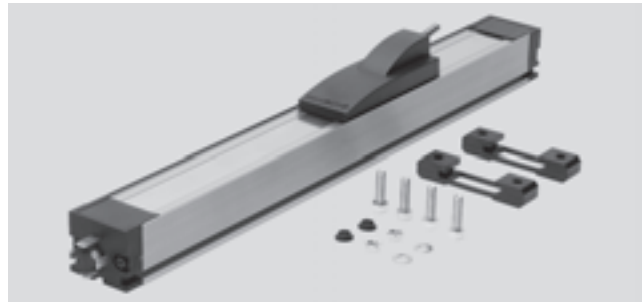

General technical data													
Stroke		225	300	360	450	500	600	750	1000	1250	1500	1750	2000
Constructional design		Open profile with cover strip and sliding cartridge											
Measuring principle		Analogue displacement encoder, with contact and absolute measurement											
Resolution	[mm]	0.01											
Max. speed of travel	[m/s]	10											
Max. acceleration	[m/s ²]	200											
Mounting position		Any											
Driver, ball coupling	Angle offset [°]	±1											
	Parallel offset [mm]	±1.5											
Service life	Strokes [10 ⁶]	Typical 100											
Connection		4-pin plug, type A DIN 43 650											
Product weight	[g]	900	1000	1100	1200	1300	1500	1800	2200	2500	3000	3500	3900

General electrical data													
Stroke		225	300	360	450	500	600	750	1000	1250	1500	1750	2000
Power supply	[V DC]	10 ¹⁾											
Max. current consumption	[mA]	4											
Wiper current	recommended [µA]	< 1											
	maximum [mA]	10 ²⁾											
Connection resistance	[kΩ]	5	5	5	5	5	5	10	10	10	20	20	20
Connection resistance tolerance	[%]	±20											
Independent linearity	[%]	0.07	0.06	0.05	0.05	0.05	0.05	0.04	0.04	0.03	0.03	0.03	0.02
Temperature coefficient	[ppm/°K]	5											
Interface		Analogue											

- 1) Stabilised power supply is recommended, max. 42 V DC permissible.
- 2) Only permissible in the short-term in the event of a fault.

Operating and environmental conditions													
Stroke		225	300	360	450	500	600	750	1000	1250	1500	1750	2000
Ambient temperature	[°C]	-30 ... +100 ¹⁾											
Protection class	top	IP40 to IEC 60529											
	bottom	IP42 to IEC 60529 ²⁾											
Vibration resistance		To DIN/IEC 68 Parts 2 – 6, severity level 2											
Continuous shock resistance		To DIN/IEC 68 Parts 2 – 27, severity level 2											
CE marking symbol (see conformity declaration)		As per EU EMC directive											

- 1) Please note temperature ranges of individual components used in a complete system solution.
- 2) The encoder slide points downwards in the inverted mounting position.

Materials		
Housing		Anodised aluminium
Cover		Plastic
Moving slide	Housing	Aluminium, plastic
	Connection	Steel ball, carbide plate
Cover		Steel band
Mounting clip		Polyetherimide

Displacement encoders MLO-POT, analogue

Technical data and accessories



Dimensions

Download CAD data → www.festo.com

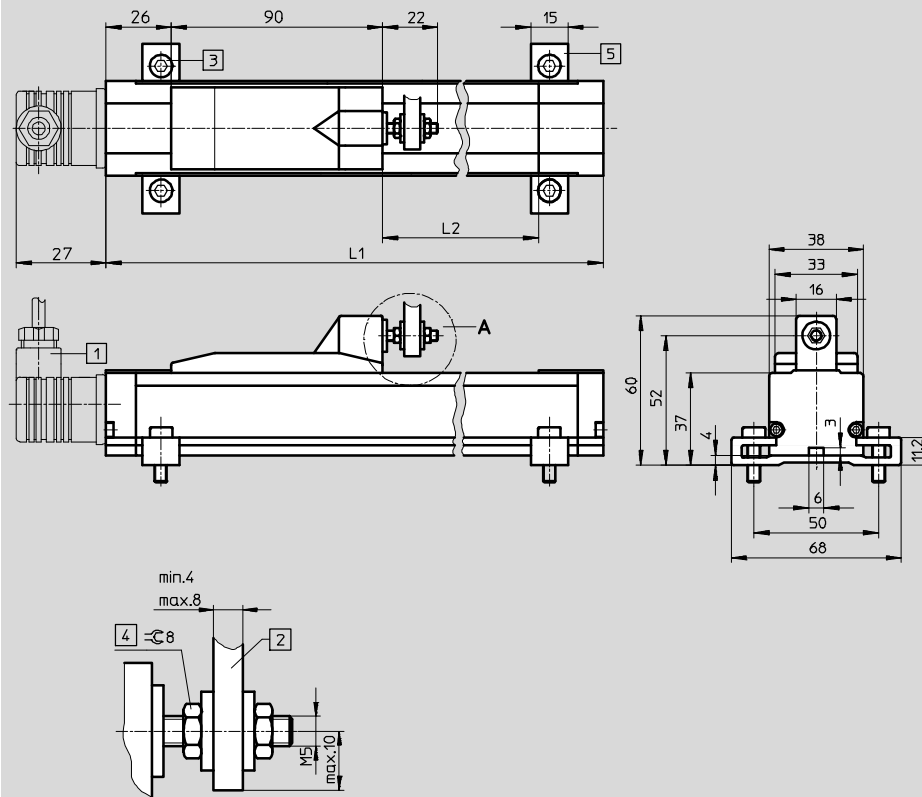

- 1 Plug socket, 4-pin to DIN 43 650
Insert 90° rotatable
(not included in scope of delivery)
- 2 Driver
(not included in scope of delivery)
- 3 Mounting screw M5x18
- 4 Hex nut M5
- 5 Adjustable mounting clips are included

Dimensions and ordering data

Stroke [mm]	L1	L2 (effective mechanical/electrical displacement)	Part No.	Type
225	376	234/228	152 625	MLO-POT-225-TLF
300	452	310/304	152 626	MLO-POT-300-TLF
360	514	372/366	152 627	MLO-POT-360-TLF
450	605	463/457	152 628	MLO-POT-450-TLF
500	656	514/508	152 629	MLO-POT-500-TLF
600	758	616/610	152 630	MLO-POT-600-TLF
750	910	768/762	152 631	MLO-POT-750-TLF
1000	1164	1022/1016	152 632	MLO-POT-1000-TLF
1250	1418	1276/1270	152 633	MLO-POT-1250-TLF
1500	1668	1526/1520	152 634	MLO-POT-1500-TLF
1750	1918	1776/1770	152 635	MLO-POT-1750-TLF
2000	2168	2026/2020	152 636	MLO-POT-2000-TLF

Ordering data – Accessories

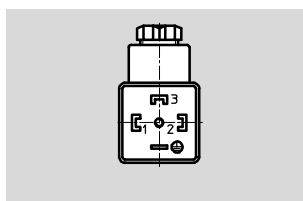

PIN	Pin allocation	Designation	Part No.	Type
1	Power supply	Connector plug	171 157	MSSD-C-4P
2	Signal			
3	0 V			
PE	PE (yellow), screen			

Displacement encoders MLO-POT, analogue

FESTO

Technical data

MLO-POT...-LWG

- | - Stroke length
100 ... 750 mm



General technical data			100	150	225	300	360	450	500	600	750
Stroke			100	150	225	300	360	450	500	600	750
Constructional design			Round profile with connecting rod								
Measuring principle			Analogue displacement encoder, with contact and absolute measurement								
Resolution	[mm]		0.01								
Max. speed of travel	[m/s]		5								
Max. acceleration	[m/s ²]		200								
Mounting position			Any								
Driver, ball coupling	Angle offset	[°]	±12.5								
	Parallel offset	[mm]	-								
Service life	Strokes	[10 ⁶]	Typical 50								
Connection			4-pin square plug								
Product weight	[g]										

General electrical data			100	150	225	300	360	450	500	600	750
Stroke			100	150	225	300	360	450	500	600	750
Power supply	[V DC]		10 ¹⁾								
Max. current consumption	[mA]		4								
Wiper current	recommended	[µA]	< 1								
	maximum	[mA]	10 ²⁾								
Connection resistance	[kΩ]		3	5	5	5	5	5	5	5	10
Connection resistance tolerance	[%]		±20								
Independent linearity	[%]		0.1	0.08	0.07	0.06	0.05	0.05	0.05	0.05	0.04
Temperature coefficient	[ppm/°K]		5								
Interface			Analogue								

- 1) Stabilised power supply is recommended, max. 42 V DC permissible.
2) Only permissible in the short-term in the event of a fault.

Operating and environmental conditions			100	150	225	300	360	450	500	600	750
Stroke			100	150	225	300	360	450	500	600	750
Ambient temperature	[°C]		-30 ... +100 ¹⁾								
Protection class			IP65								
Vibration resistance			To DIN/IEC 68 Parts 2 – 6, severity level 2								
Continuous shock resistance			To DIN/IEC 68 Parts 2 – 27, severity level 2								
CE marking symbol (see conformity declaration)			As per EU EMC directive								

- 1) Please note temperature ranges of individual components used in a complete system solution.

Materials		
Housing		Anodised aluminium
Bearing cap		Reinforced polyester
Bearing seal		Nitrile rubber
Connecting rod		Corrosion resistant steel
Wiper	Contact	Stainless steel
	Silencer	Elastomer

Displacement encoders MLO-POT, analogue

Technical data and accessories

<p> Note</p> <p>The mechanical vibrations of the piston rod must not be transmitted to the displacement encoder. The displacement encoder is earthed to a screw on the end cap using a</p>		<p>cable lug or earthing strap that must be connected to the earthing screw of the SPC11-...-LWG housing. The earthing cable should not be longer than the encoder cable of the</p>	<p>SPC11-...-LWG. The connection must be designed to be low-resistance. The conductor cross-section must be at least 1.5 mm².</p>	<p>An earthing strap (braided) should be used instead of a round cable as earthing straps are considerably more effective at dissipating interference.</p>
MLO-POT-...-LWG				
Housing	Anodised aluminium			
Bearing cap	Reinforced polyester			
Bearing seal	Nitrile rubber			
Connecting rod	Corrosion resistant steel			
Rod seal	Polytetrafluoroethylene			
Lubricant	ISOFLEX Topas MB52			
Resistor element	Conductive plastic			
Wiper	Contact	Stainless steel		
	Silencer	Elastomer		

Dimensions

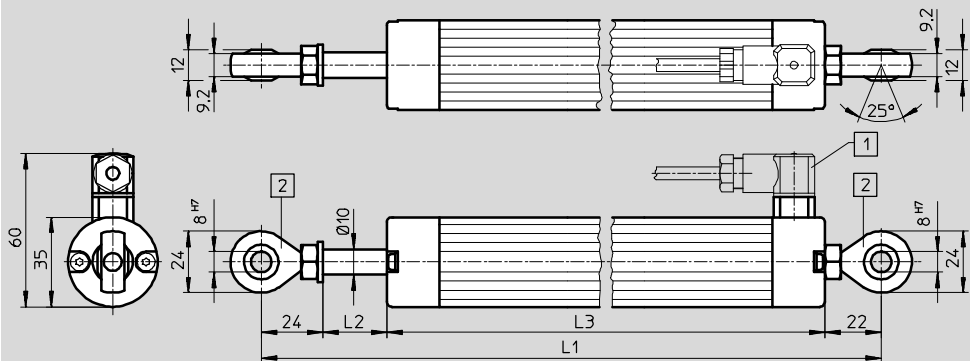

Download CAD data → www.festo.com

1 Plug socket, 4-pin
Type: SD-4-WD-7
Insert 90° rotatable
(not included in scope of delivery)

2 Rod eye, backlash-free

Dimensions and ordering data					
Stroke [mm]	L1	L2 (effective mechanical/electrical displacement)	L3	Part No.	Type
100	273	105/102	227	192 213	MLO-POT-100-LWG
150	323	155/152	277	192 214	MLO-POT-150-LWG
225	400	231/228	354	152 645	MLO-POT-225-LWG
300	476	307/304	430	152 646	MLO-POT-300-LWG
360	551	368/366	505	152 647	MLO-POT-360-LWG
450	665	460/457	619	152 648	MLO-POT-450-LWG
500	730	510/508	684	152 649	MLO-POT-500-LWG
600	856	612/610	810	152 650	MLO-POT-600-LWG
750	1040	764/762	994	152 651	MLO-POT-750-LWG

Ordering data – Accessories

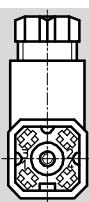
	PIN	Pin allocation	Designation	Part No.	Type
	1	Power supply	Plug socket	194 332	SD-4-WD-7
	2	Signal			
	3	0 V			
	4	PE (yellow), screen			

Displacement encoders MME-MTS, digital

Technical data

MME-MTS-...-AIF

- Stroke length
225 ... 2000 mm



General technical data		225	300	360	450	500	600	750	1000	1250	1500	1750	2000
Stroke													
Constructional design		Closed profile with outer slide											
Measuring principle		Digital, magnetostrictive, non-contacting and absolute measurement											
Resolution	[mm]	< 0.01											
Max. speed of travel	[m/s]	10											
Max. acceleration	[m/s ²]	200											
Mounting position		Any											
Driver,	Angle offset	[°]	±1										
ball coupling	Parallel offset	[mm]	±1.5										
Service life	MTBF	[10 ⁶ /h]	> 4 ¹⁾										
Connection		6-pin round plug to DIN 45 322											
Product weight	[g]	620	710	780	890	950	1070	1250	1550	1850	2150	2450	2750

1) For the waveguide

General electrical data		
Power supply	[V DC]	24 (-15/+20%)
Max. current consumption	[mA]	90
Independent linearity	[%]	0.02 ¹⁾
Temperature coefficient	[ppm/°K]	15
Interface		Digital, CAN with protocol: SPC-AIF

1) Min. ±50 µm

Operating and environmental conditions		
Ambient temperature	[°C]	-40 ... +75 ¹⁾
Protection class		IP65
Vibration resistance		To DIN/IEC 68 Parts 2 – 6, severity level 1
Continuous shock resistance		To DIN/IEC 68 Parts 2 – 27, severity level 1
CE marking symbol (see conformity declaration)		As per EU EMC directive

1) Please note temperature ranges of individual components used in a complete system solution

Materials		
Housing		Wrought aluminium alloy, anodised
Cover		Die-cast aluminium, painted
Moving slide	Housing	Reinforced polyester, permanent magnet
	Connection	Steel ball, hard metal plate
Mounting clip		Polyetherimide

Displacement encoders MME-MTS, digital

Technical data

FESTO

Dimensions

Download CAD data → www.festo.com

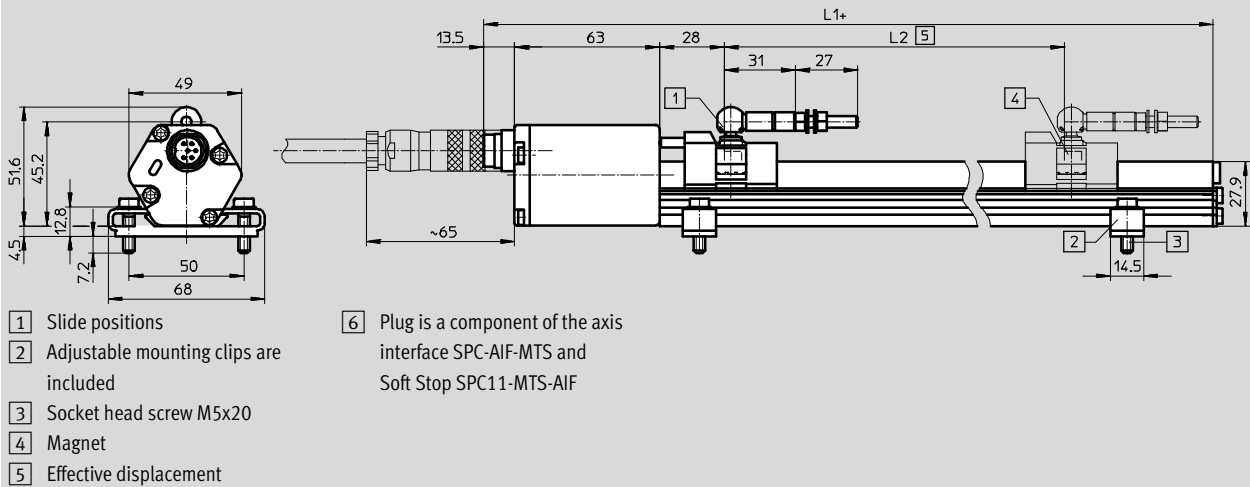

Dimensions and ordering data

Stroke [mm]	L1	L2 (effective path)	Part No.	Type
225	395	225	178 310	MME-MTS-225-TLF-AIF
300	470	300	178 309	MME-MTS-300-TLF-AIF
360	530	360	178 308	MME-MTS-360-TLF-AIF
450	620	450	178 307	MME-MTS-450-TLF-AIF
500	670	500	178 306	MME-MTS-500-TLF-AIF
600	770	600	178 305	MME-MTS-600-TLF-AIF
750	920	750	178 304	MME-MTS-750-TLF-AIF
1000	1170	1000	178 303	MME-MTS-1000-TLF-AIF
1250	1420	1250	178 302	MME-MTS-1250-TLF-AIF
1500	1670	1500	178 301	MME-MTS-1500-TLF-AIF
1750	1920	1750	178 300	MME-MTS-1750-TLF-AIF
2000	2170	2000	178 299	MME-MTS-2000-TLF-AIF

Pin allocation

PIN	
1	CAN LOW
2	CAN HIGH
3	Unused
4	Unused
5	+24 V
6	0 V
PE	Screen

Ordering data – Connecting cables and plugs

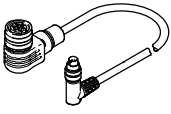
Description	Cable length [m]	Part No.	Type
Connection between displacement encoder MME-MTS and proportional directional control valve VPWP			
 For displacement encoder MME-MTS	2	575898	NEBP-M16W6-K-2-M9W5

Festo - Your Partner in Automation



1 Festo Inc.
5300 Explorer Drive
Mississauga, ON L4W 5G4
Canada

Festo Customer Interaction Center
Tel: 1 877 463 3786
Fax: 1 877 393 3786
Email: customer.service.ca@festo.com



2 Festo Pneumatic
Av. Ceylán 3,
Col. Tequesquináhuac
54020 Tlalnepantla,
Estado de México

Multinational Contact Center
01 800 337 8669
ventas.mexico@festo.com



3 Festo Corporation
1377 Motor Parkway
Suite 310
Islandia, NY 11749

Festo Customer Interaction Center
1 800 993 3786
1 800 963 3786
customer.service.us@festo.com



4 Regional Service Center
7777 Columbia Road
Mason, OH 45040

Connect with us



www.festo.com/socialmedia



www.festo.com

Subject to change