

Multi-position cylinders/Adapter kits

FESTO

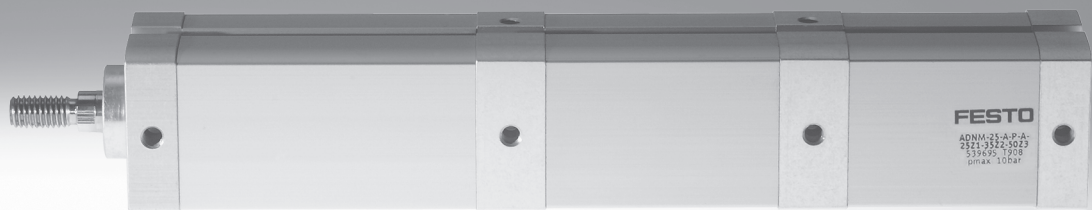

- 7 - Type discontinued
Available up until 2010

Multi-position cylinders ADN, ADVUP

Product range overview

FESTO

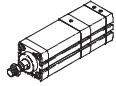
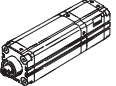
Function	Design	Type	Piston Ø [mm]	Stroke [mm]	Piston rod		→ Page/Internet
					With female thread	With male thread	
Double-acting		ADNM Single-ended piston rod	25	1 ... 1,000	■	■	4
			40, 63, 100	1 ... 2,000	■	■	
		ADVUP Single-ended piston rod	25	1 ... 1,000	■	■	28
			40, 63, 100	1 ... 2,000	■	■	

Function principle

By connecting 2 to 5 cylinders in series with the same piston Ø and different stroke lengths, up to 6 positions can be approached.

The following rules must be observed:

- 1 Each subsequent cylinder stroke must be greater than the one that preceded it.
- 2 The sum of all individual strokes may not exceed the total stroke, i.e.
for piston Ø 25: 500 mm
for piston Ø 40, 63, 100: 2,000 mm
- 3 The stroke of the last cylinder must not exceed a maximum permitted stroke length, i.e.
for piston Ø 25: 300 mm
for piston Ø 40, 63, 100: 1,000 mm
- 4 The strokes of the individual cylinders must not exceed in each case a maximum permitted stroke length, i.e.
for piston Ø 25: 200 mm
for piston Ø 40, 63: 300 mm
for piston Ø 100: 400 mm

Example for piston Ø 25 mm:

ADNM-25 for 5 positions at 0, 25, 50, 100 and 200 mm.

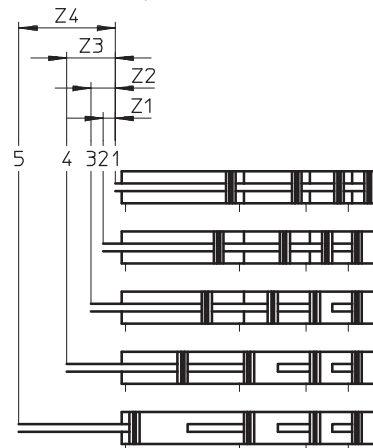

- 1 Each subsequent cylinder stroke must be greater than the one that preceded it:
 $Z1 = 25 \text{ mm} < Z2 = 50 \text{ mm} < Z3 = 100 \text{ mm} < Z4 = 200 \text{ mm}$
- 2 Sum of individual strokes:
 $= 375 \text{ mm} < 500 \text{ mm}$
- 3 Max. stroke of the last cylinder:
 $Z4 = 200 \text{ mm} < 300 \text{ mm}$
- 4 Max. strokes of the individual cylinders:
 $Z3 = 100 \text{ mm} < 200 \text{ mm}$
 $Z2 = 50 \text{ mm} < 200 \text{ mm}$
 $Z1 = 25 \text{ mm} < 200 \text{ mm}$

Adapter kits DPNC/DPNG/DPNA/DPVU

Product range overview



Design	Type	For cylinders	Piston Ø [mm]	Overall stroke length [mm]	→ Page/Internet
	DPNC	DNCB, DNC, ADVC ADN Ø125 ADVU Ø125	32, 40, 50, 63, 80, 100, 125	1,000	42
	DPNG	DNG	32, 40, 50, 63, 80, 100	1,000	42
	DPNA	ADN	12, 16, 20, 25, 32, 40, 50, 63, 80, 100	600 ... 1,000	43
	DPVU	ADVU	12, 16, 20, 25, 32, 40, 50, 63, 80, 100	400 ... 800	43

Function principle

A 3 or 4-position cylinder consists of two separate cylinders whose piston rods advance in opposing directions.

Depending upon actuation and stroke pattern, this type of cylinder can assume up to four positions. In each

case the cylinder is driven precisely against a stop. If one end of the piston rod is fixed, the cylinder barrel

executes the movement. The cylinder must be connected with flexible line connections.

Implementing 3 positions

Two cylinders with identical stroke length must be connected to this end.

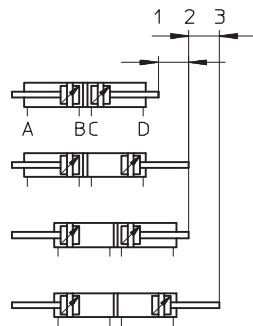

Implementing 4 positions

Two cylinders with different stroke lengths must be connected to this end.

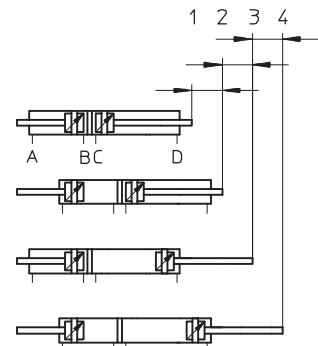

Multi-position cylinders ADNM, standard port pattern

Peripherals overview

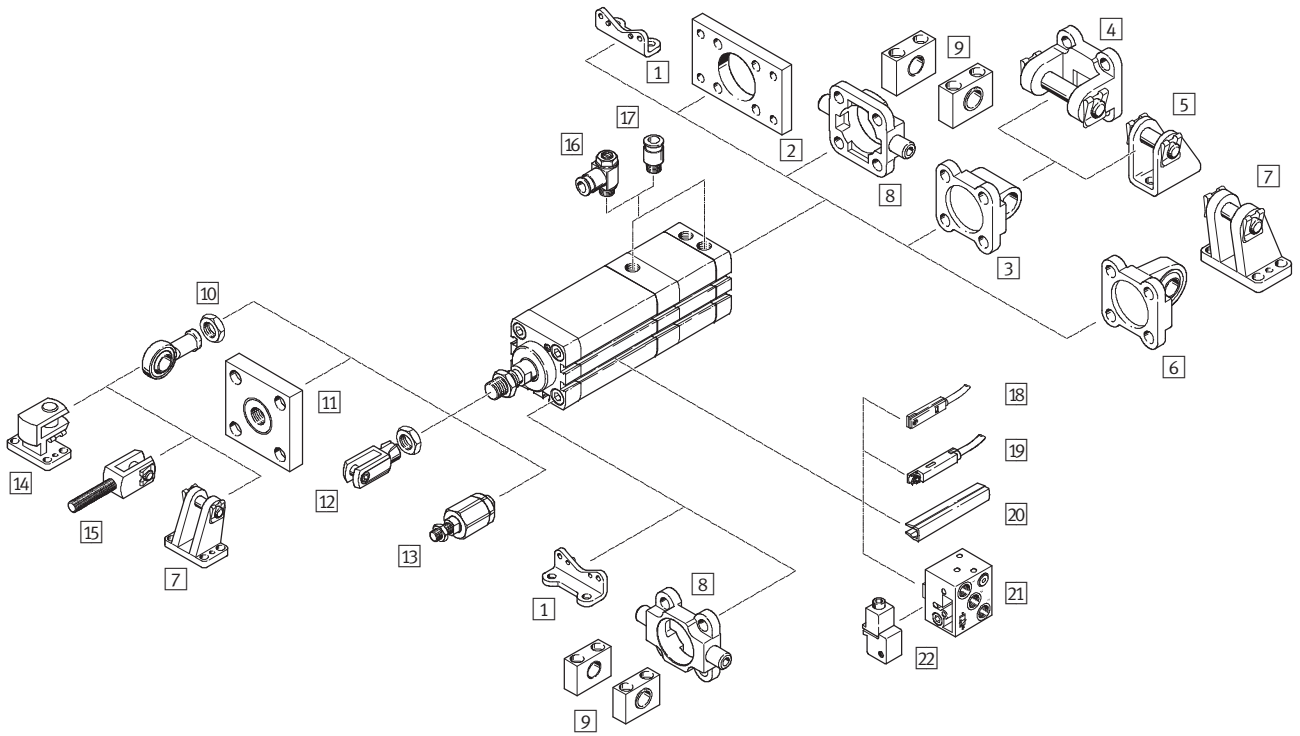

Multi-position cylinders ADN, standard port pattern

Peripherals overview

Mounting attachments and accessories					
	Brief description	∅ 25	∅ 40, 63, 100	→ Page/Internet	
1	Foot mounting HNA	For bearing and end caps	■	■	16
2	Flange mounting FNC	For end caps	■	■	17
3	Swivel flange SNCL	For end caps	■	■	18
4	Swivel flange SNCB	For swivel flange SNCL	-	■	20
5	Clevis foot LBN/CRLBN	For swivel flange SNCL	■	-	19
6	Swivel flange SNCS	For end caps	-	■	18
7	Clevis foot LBG	For swivel flange SNCS	-	■	22
8	Trunnion flange ZNCF/CRZNG	For bearing caps	-	■	21
9	Trunnion support LNZG	For trunnion flange ZNCF/CRZNG	-	■	21
10	Rod eye SGS/CRSGS	With spherical bearing	■	■	22
11	Coupling piece KSG	For compensating radial deviations	■	■	22
12	Rod clevis SG/CRSG	Permits a swivelling movement of the cylinder in one plane	■	■	22
13	Self-aligning rod coupler FK	For compensating radial and angular deviations	■	■	22
14	Right-angle clevis foot LQG	For rod eye SGS	-	■	22
15	Rod clevis SGA	With male thread	-	■	22
16	One-way flow control valve GRLA	For speed regulation	■	■	22
17	Push-in fitting QS	For connecting compressed air tubing with standard external diameters	■	■	quick star
18	Proximity sensor SME/SMT-8	Can be integrated in the sensor slot of the cylinder profile barrel	■	■	23
19	Proximity sensor SME/SMT-8M	Can be integrated in the sensor slot of the cylinder profile barrel	■	■	23
20	Slot cover ABP-5-S	For protecting the sensor cable and keeping dirt out of the sensor slots	■	■	24
21	Proximity sensor SMPO-8E	Pneumatic output signal	■	■	24
22	Mounting kit SMB-8E	For proximity sensor SMPO-8E	■	■	24

Multi-position cylinders ADN, standard port pattern

Type codes

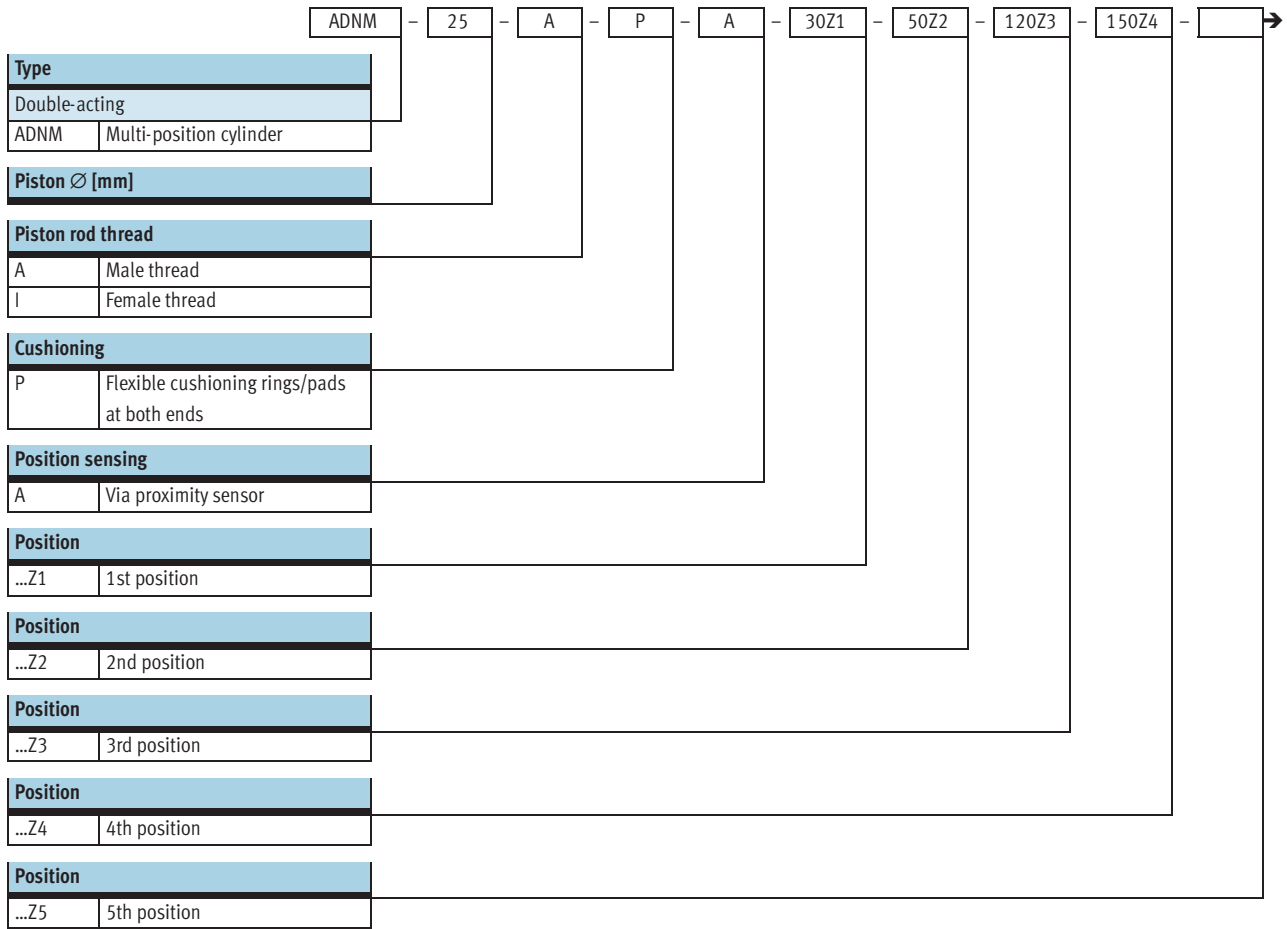

Multi-position cylinders ADNM, standard port pattern

Type codes

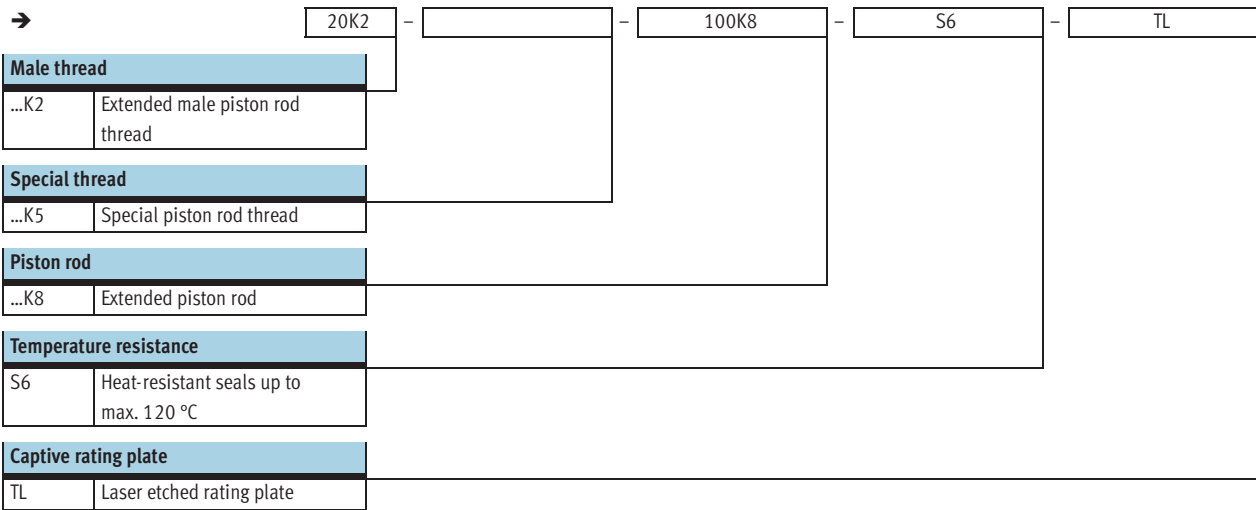

Multi-position cylinders ADN, standard port pattern

FESTO

Technical data

Function

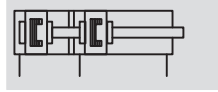

⌀ - Diameter
25 ... 100 mm

— | - Stroke length
1 ... 2,000 mm

Variants



K2



K5



K8



S6

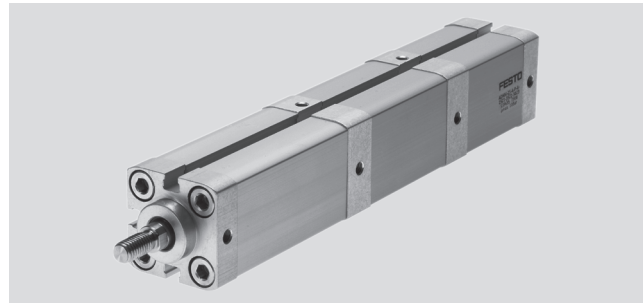

General technical data					
Piston Ø		25	40	63	100
Pneumatic connection		M5	M5	G1/8	G1/8
Piston rod thread	Female	M6	M10	M12	M16
	Male	M8	M12x1.25	M16x1.5	M20x1.5
Constructional design		Piston			
		Piston rod			
		Cylinder barrel			
Cushioning		Flexible cushioning rings/pads at both ends			
Position sensing		Via proximity sensor			
Type of mounting		Via female threads			
		Via accessories			
Mounting position		Any			

Operating and environmental conditions					
Piston Ø		25	40	63	100
Operating medium		Filtered compressed air, lubricated or unlubricated			
Operating pressure [bar]	2nd position	0.8 ... 10		0.6 ... 10	
	3rd position	1.1 ... 10		0.9 ... 10	
	4th position	1.4 ... 10		1.2 ... 10	
	5th position	1.7 ... 10		1.5 ... 10	
Ambient temperature ¹⁾ [°C]		-20 ... +80			
	S6	0 ... +120			
Corrosion resistance class CRC ²⁾		2			

1) Note operating range of proximity sensors

2) Corrosion resistance class 2 to Festo standard 940 070

Components subject to moderate corrosion stress. Externally visible parts with primarily decorative surface requirements which are in direct contact with a normal industrial environment or media such as coolants or lubricating agents

Multi-position cylinders ADN, standard port pattern

Technical data

Forces [N] and impact energy [J]				
Piston Ø	25	40	63	100
Theoretical force at 6 bar, advancing	295	754	1870	4712
Theoretical force at 6 bar, retracting	247	633	1681	4417
Max. impact energy at the end positions	S6	0.3	0.7	1.3
		0.15	0.35	0.65

Max. lateral force F_q as a function of the projection x

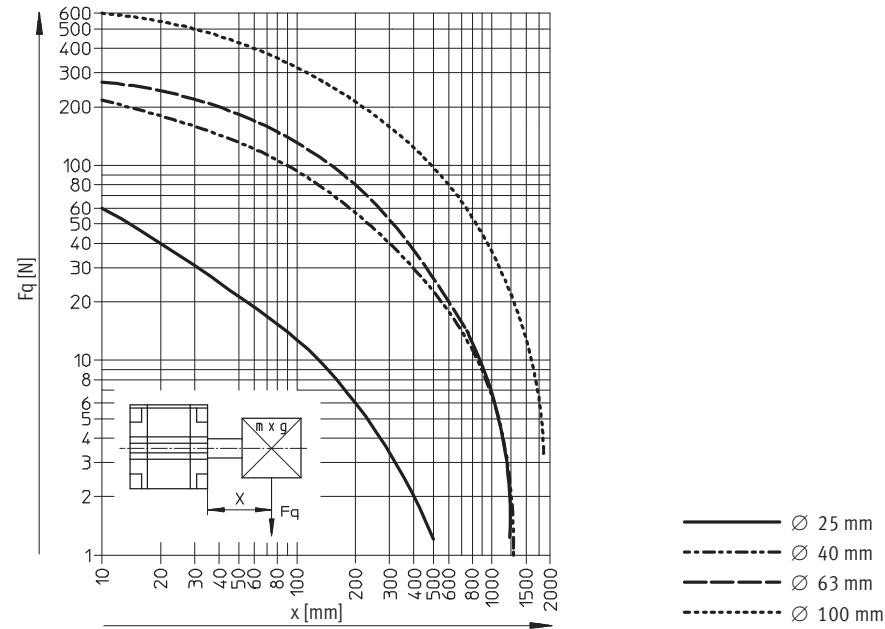

Materials

Sectional view

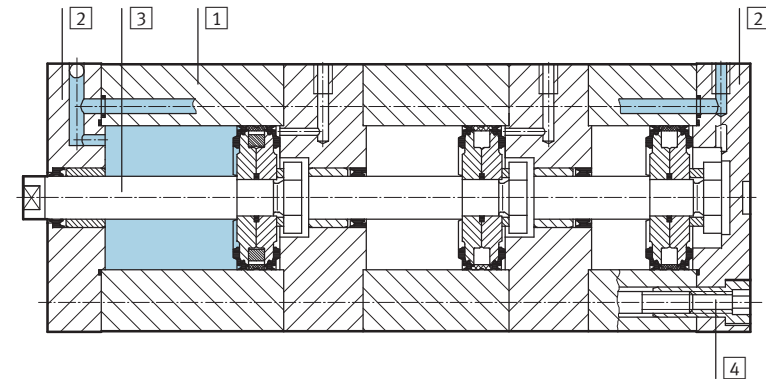

Multi-position cylinder	Basic version	S6
1 Cylinder barrel	Anodised aluminium	Anodised aluminium
2 Cover	Anodised aluminium	Anodised aluminium
3 Piston rod	High-alloy steel	High-alloy steel
4 Flange screws	Galvanised steel	Galvanised steel
- Seals	Polyurethane	Fluoro elastomer

Multi-position cylinders ADN, standard port pattern



Technical data

Dimensions – Basic version

Download CAD data → www.festo.com

∅ 25/Z2 – 2 cylinders

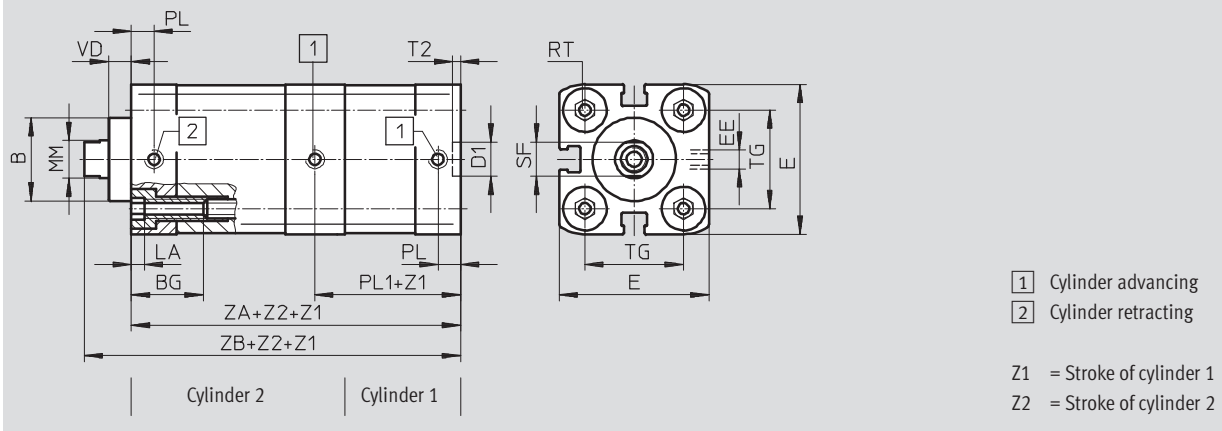

∅ 40 ... 100/Z2 – 2 cylinders

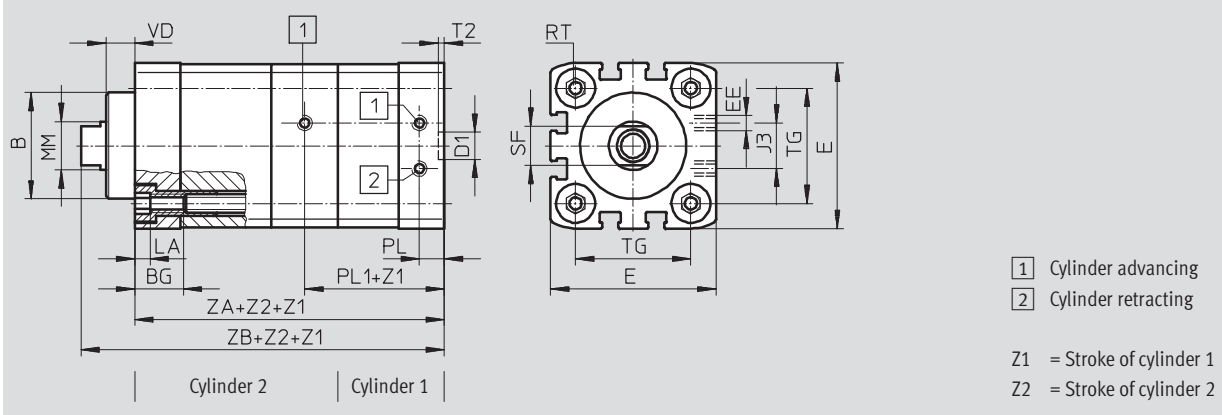

Z3 – 3 cylinders

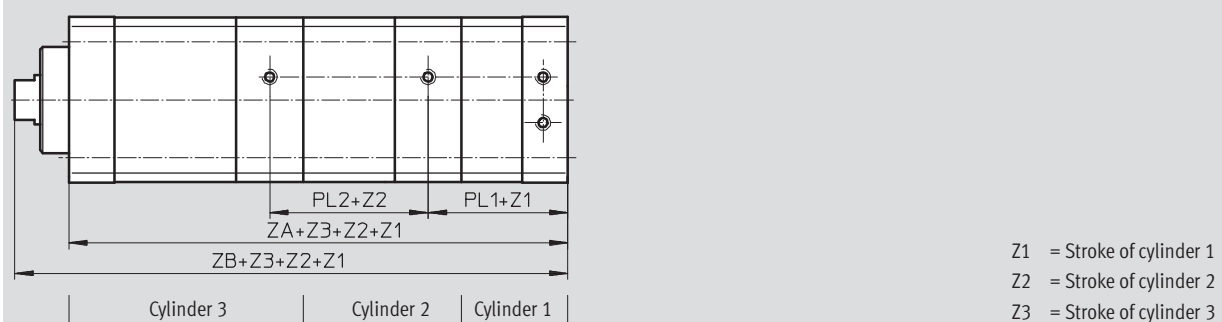

Z4 – 4 cylinders

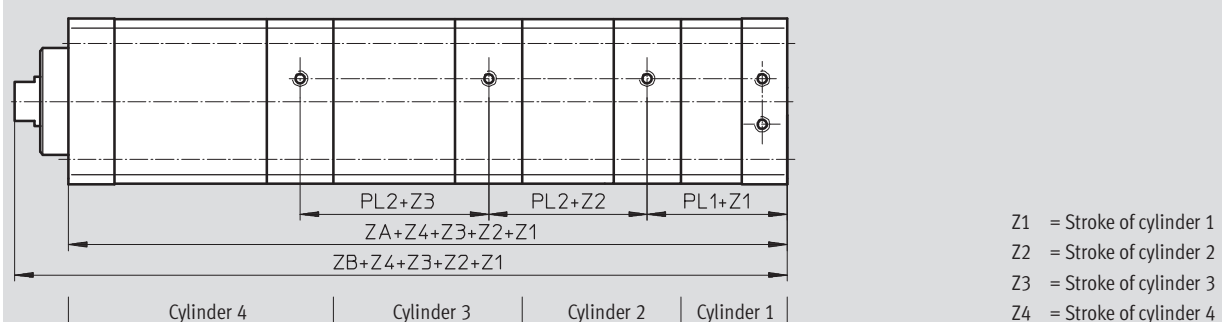

Multi-position cylinders ADN, standard port pattern

Technical data

Dimensions – Variants

Download CAD data → www.festo.com

Z5 – 5 cylinders

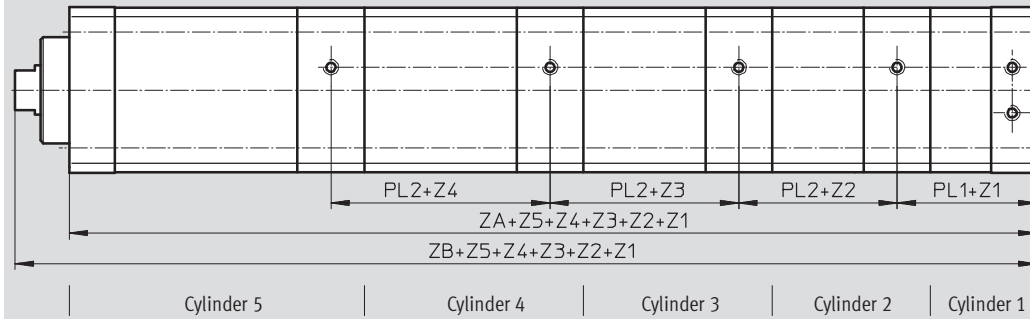

Z1 = Stroke of cylinder 1 Z4 = Stroke of cylinder 4
 Z2 = Stroke of cylinder 2 Z5 = Stroke of cylinder 5
 Z3 = Stroke of cylinder 3

∅	B	BG	D1	E	EE	J3	LA	MM
[mm]	∅ f8	min.	∅ H9	+0.3			+0.2	∅ h9
25	22	15	9	39.5	M5	-	5	10
40	35	16		54.5		15		16
63	42	17	12	75.5	G3/8	23		20
100	55			113.5		40	25	

∅	PL	PL1	PL2	RT	SF	T2	TG	VD
[mm]	+0.2	+0.2	+0.2			+0.1	±0.2	
25	6	38.3	34.2	M5	9	2.1	26	6
40	8.2	40.4	39.5	M6	13		38	9.5
63		44	42	M8	17	2.6	56.5	12
100	10.5	51.2	52	M10	21		89	15.5

∅	ZA				ZB			
	Number of cylinders				Number of cylinders			
[mm]	2	3	4	5	2	3	4	5
25	76.3 ^{+1.2}	110.5 ^{+1.8}	144.7 ^{+2.4}	178.9 ⁺³	88.5 ^{+1.6}	122.7 ^{+2.2}	156.9 ^{+2.8}	191.1 ^{+3.5}
40	86.2 ^{+1.2}	125.5 ^{+1.8}	166.9 ^{+2.4}	209.9 ⁺³	104.6 ^{+1.6}	143.9 ^{+2.2}	185.2 ^{+2.8}	228.2 ^{+3.5}
63	93.3 ^{+1.2}	135.7 ^{+1.8}	180.2 ^{+2.4}	226.3 ⁺³	114.6 ^{+1.6}	157 ^{+2.2}	201.4 ^{+2.8}	247.5 ^{+3.5}
100	120.9 ^{+1.2}	172.8 ^{+1.8}	227 ^{+2.4}	282.8 ⁺³	147.9 ^{+1.6}	199.8 ^{+2.2}	253.9 ^{+2.8}	309.7 ^{+3.5}

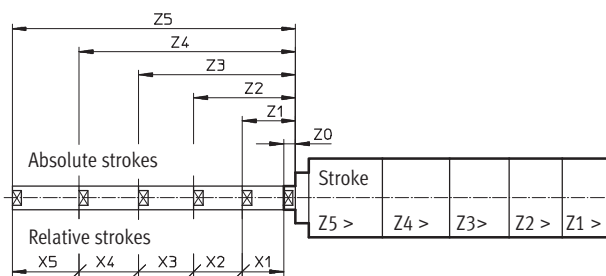

Multi-position cylinders ADN, standard port pattern



Technical data

Dimensions – Variants

Download CAD data → www.festo.com

Basic version

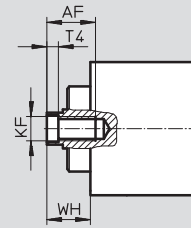
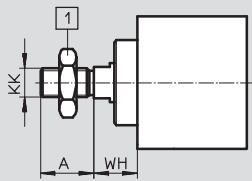

1 Hex nut to DIN 439-B
only with \varnothing 40 ... 100

K2 – Extended male piston rod thread

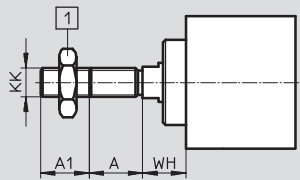

1 Hex nut to DIN 439-B
only with \varnothing 40 ... 100

K5 – Special piston rod thread

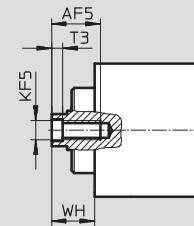
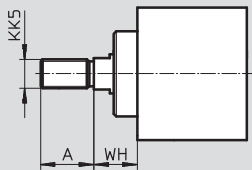

K8 – Extended piston rod

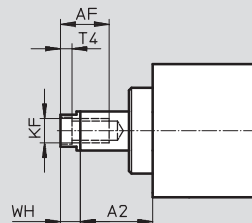
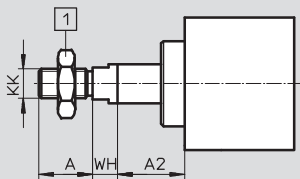

1 Hex nut to DIN 439-B
only with \varnothing 40 ... 100

Multi-position cylinders ADN, standard port pattern



Technical data

∅ [mm]	A -0.5	A1	A2	AF min.	AF5 min.	KF	KF5	KK	KK5	T3	T4	WH +1.3
25	16	1 ... 20	1 ... 150	14	12	M6	M5	M8	M10x1.25 M10	2	2.6	11.8
40	22			20	16	M10	M8	M12x1.25	M10x1.25 M12	3.3	4.7	18
63	28			20	M12	M10	M16x1.5	M12x1.25 M16	4.7	6.1	21	
100	40	1 ... 30		25	-	M16	-	M20x1.5	M16x1.5 M20	-	7	26.5

Multi-position cylinders ADNM, standard port pattern



Ordering data – Modular products

M Mandatory data							O Options			
Module No.	Function	Size	Type of thread	Cushioning	Position sensing	1st position	2nd position	3rd position	4th position	5th position
539 695	ADNM	25	A	P	A	...Z1	...Z2	...Z3	...Z4	...Z5
539 696		40	I							
539 697		63								
539 698		100								
Order example										
539 695	ADNM	- 25	- A	- P	- A	- 30Z1	- 50Z2	- 120Z3	- 200Z4	-

Ordering table									
Size	25	40	63	100	Condi-tions	Code	Enter code		
M Module No.	539 695	539 696	539 697	539 698					
Function	Multi-position cylinder, standard port pattern					ADNM		ADNM	
Size [mm]	25	40	63	100		-...			
Type of thread	Male thread					-A			
	Female thread					-I			
Cushioning	Flexible cushioning rings/pads at both ends					-P		-P	
Position sensing	Via proximity sensor					-A		-A	
1st position [mm]	1 ... 200	1 ... 300	1 ... 300	1 ... 400	1	-...Z1		- ... Z1	
2nd position [mm]	1 ... 300	1 ... 1000	1 ... 1000	1 ... 1000	1 2	-...Z2		- ... Z2	
3rd position [mm]	1 ... 300	1 ... 1000	1 ... 1000	1 ... 1000	1 2	-...Z3			
4th position [mm]	1 ... 300	1 ... 1000	1 ... 1000	1 ... 1000	1 2	-...Z4			
5th position [mm]	1 ... 300	1 ... 1000	1 ... 1000	1 ... 1000	1 2	-...Z5			

The end of the retracted piston rod is the reference point for all positions.

- 1 **Z1 ... Z5** The subsequent position must be larger than the one that precedes it:
 $Z1 < Z2 < Z3 < Z4 < Z5$.
 Max. total of all positions:
 Size 25: max. 1000 mm
 Size 40, 63, 100: max. 2000 mm

- 2 **Z2 ... Z5** Max. permissible stroke except for the last position (visible piston rod):
 Size 25: 200 mm
 Size 40, 63: 300 mm
 Size 100: 400 mm

Transfer order code

	ADNM	-		-		-	P	-	A	-	...Z1	-	...Z2	-		-		-	
--	------	---	--	---	--	---	---	---	---	---	-------	---	-------	---	--	---	--	---	--

Multi-position cylinders ADN, standard port pattern

Ordering data – Modular products



→ Options

Male thread extended	Special thread	Piston rod extended	Temperature resistance	Captive rating plate
...K2	"..."K5	...K8	S6	TL
- 20K2	- "M10"K5	- 100K8	-	-

Ordering table							
Size	25	40	63	100	Condi- tions	Code	Enter code
Male thread extended [mm]	Extended male piston rod thread					-...K2	
Special piston rod thread	M10x1.25	M10x1.25	M12x1.25	M16x1.5	<input type="checkbox"/> 3	-"..."K5	
	M10	M12	M16	M20			
	M5	M8	M10	-	<input type="checkbox"/> 4		
Piston rod extended [mm]	Extended piston rod					-...K8	
	1 ... 300	1 ... 400	1 ... 400	1 ... 500	<input type="checkbox"/> 5		
Temperature resistance	Heat-resistant seals up to max. 120 °C					-S6	
Captive rating plate	Laser etched rating plate					-TL	

- 3 K5 Only with piston rod thread A (male thread)
- 4 K5 Only with piston rod thread I (female thread)

- 5 K8 The sum of the length of the last position and piston rod extension must not exceed the maximum permissible length of the last position

Transfer order code

- - - - -

Multi-position cylinders ADNM, standard port pattern



Accessories

Foot mounting HNA

Material:

HNA: Galvanised steel

HNA-...-R3: Steel with protective coating

Free of copper, PTFE and silicone

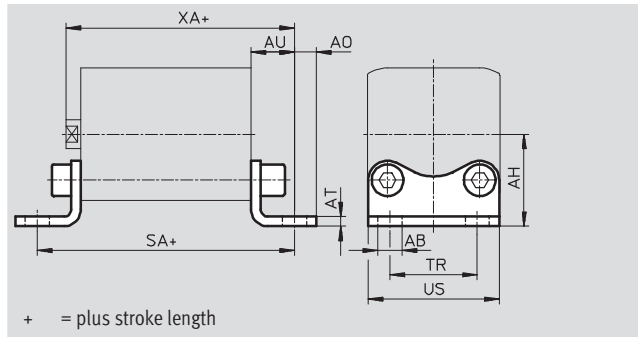

Dimensions and ordering data									
For \varnothing	AB	AH	AO	AT	AU	SA	TR	US	XA
[mm]	\varnothing H14	JS14		± 0.5	± 0.2		± 0.2	-0.5	
25	7	29	6.25	4	16	71	26	38.5	61
40	10	38	9		18	81	36	54	69
63		50	8	5	21	91	50	75	78
100	14.5	74	12.5	6	27	121	75	110	103

For \varnothing	Basic version				R3 – High corrosion protection			
	CRC ¹⁾	Weight	Part No.	Type	CRC ¹⁾	Weight	Part No.	Type
[mm]		[g]				[g]		
25	2	55	537 240	HNA-25	3	55	537 255	HNA-25-R3
40	2	90	537 242	HNA-40	3	90	537 257	HNA-40-R3
63	2	180	537 244	HNA-63	3	180	537 259	HNA-63-R3
100	2	470	537 250	HNA-100	3	470	537 261	HNA-100-R3

1) Corrosion resistance class 2 to Festo standard 940 070
 Components subject to moderate corrosion stress. Externally visible parts with primarily decorative surface requirements which are in direct contact with a normal industrial environment or media such as coolants or lubricating agents.
 Corrosion resistance class 3 to Festo standard 940 070
 Components requiring higher corrosion resistance. External visible parts in direct contact with industrial atmospheres or media such as solvents and cleaning agents, with a predominantly functional requirement for the surface

Multi-position cylinders ADNM, standard port pattern

Accessories

Flange mounting FNC

Material:
Galvanised steel
Free of copper, PTFE and silicone

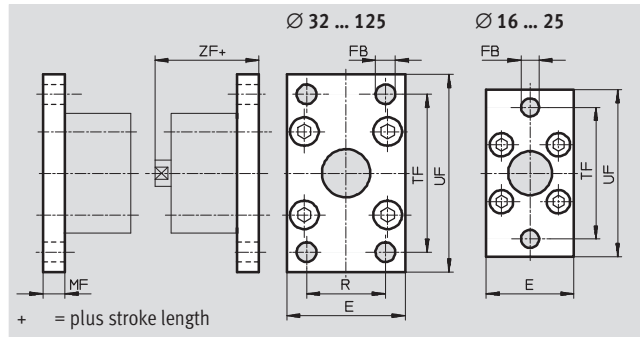

Dimensions and ordering data											
For Ø	E	FB	MF	R	TF	UF	ZF	CRC ¹⁾	Weight	Part No.	Type
[mm]		Ø				±1			[g]		
25	40	6.6	8	–	60	76	53	2	–	537 248	FNC-25
40	54	9	10	36	72	90	61	2	280	174 377	FNC-40
63	75		12	50	100	120	69	2	690	174 379	FNC-63
100	110	14	16	75	150	175	92	2	2400	174 381	FNC-100

1) Corrosion resistance class 2 to Festo standard 940 070
Components subject to moderate corrosion stress. Externally visible parts with primarily decorative surface requirements which are in direct contact with a normal industrial environment or media such as coolants or lubricating agents

Multi-position cylinders ADNM, standard port pattern



Accessories

Swivel flange SNCL

Material:
 SNCL: Die-cast aluminium
 SNCL...-R3: Die-cast aluminium with protective coating
 Free of copper, PTFE and silicone

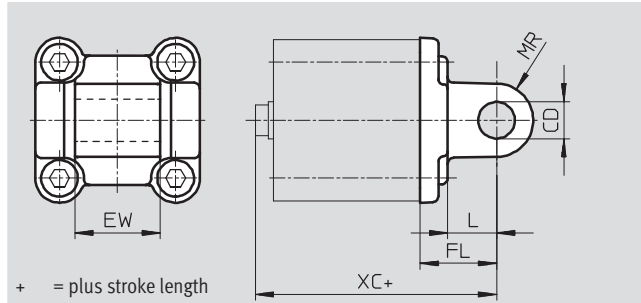
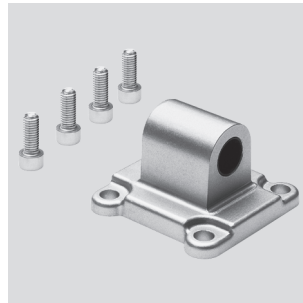

Dimensions and ordering data						
For \varnothing [mm]	CD \varnothing H9	EW	FL ± 0.2	L	MR	XC
25	8	16 _{h12}	20	14	8	65
40	12	28 _{-0.2/-0.6}	25	16	12	76
63	16	40 _{-0.2/-0.6}	32	21	16	89
100	20	60 _{-0.2/-0.6}	41	27	20	117

For \varnothing [mm]	Basic version				R3 – High corrosion protection			
	CRC ¹⁾	Weight [g]	Part No.	Type	CRC ¹⁾	Weight [g]	Part No.	Type
25	2	45	537 793	SNCL-25	3	45	537 797	SNCL-25-R3
40	2	115	174 405	SNCL-40	–	–	–	–
63	2	270	174 407	SNCL-63	–	–	–	–
100	2	700	174 409	SNCL-100	–	–	–	–

1) Corrosion resistance class 2 to Festo standard 940 070
 Components subject to moderate corrosion stress. Externally visible parts with primarily decorative surface requirements which are in direct contact with a normal industrial environment or media such as coolants or lubricating agents.
 Corrosion resistance class 3 to Festo standard 940 070
 Components requiring higher corrosion resistance. External visible parts in direct contact with industrial atmospheres or media such as solvents and cleaning agents, with a predominantly functional requirement for the surface

Swivel flange SNCS

Material:
 Die-cast aluminium

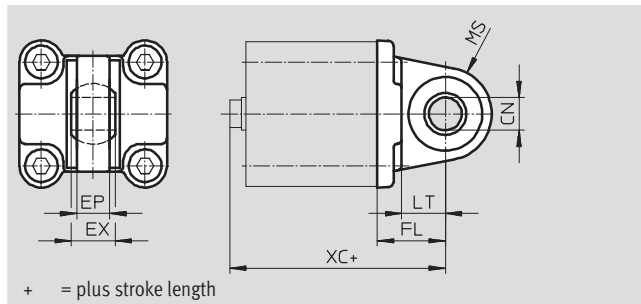
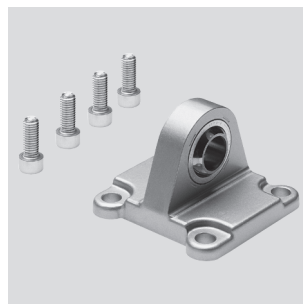

Dimensions and ordering data											
For \varnothing [mm]	CN \varnothing H7	EP ± 0.2	EX	FL ± 0.2	LT	MS	XC	CRC ¹⁾	Weight [g]	Part No.	Type
40	12	12	16	25	16	17	70	2	125	174 398	SNCS-40
63	16	15	21	32	21	22	81	2	280	174 400	SNCS-63
100	20	18	25	41	27	29	108	2	700	174 402	SNCS-100

1) Corrosion resistance class 2 to Festo standard 940 070
 Components subject to moderate corrosion stress. Externally visible parts with primarily decorative surface requirements which are in direct contact with a normal industrial environment or media such as coolants or lubricating agents

Multi-position cylinders ADN, standard port pattern

Accessories

Clevis foot LBN

Material:
Galvanised steel
Free of copper, PTFE and silicone

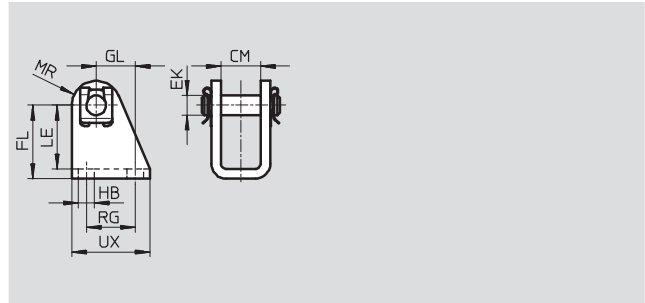

Dimensions and ordering data													
For \varnothing	CM	EK \varnothing	FL	GL	HB \varnothing	LE	MR	RG	UX	CRC ¹⁾	Weight [g]	Part No.	Type
25	16.1	8	30 +0.4/-0.2	16	6.6	26	10	20	32	2	81	6 059	LBN-20/25

1) Corrosion resistance class 2 to Festo standard 940 070
Components subject to moderate corrosion stress. Externally visible parts with primarily decorative surface requirements which are in direct contact with a normal industrial environment or media such as coolants or lubricating agents

Clevis foot CRLBN, stainless steel

Material:
High-alloy steel
Free of copper, PTFE and silicone

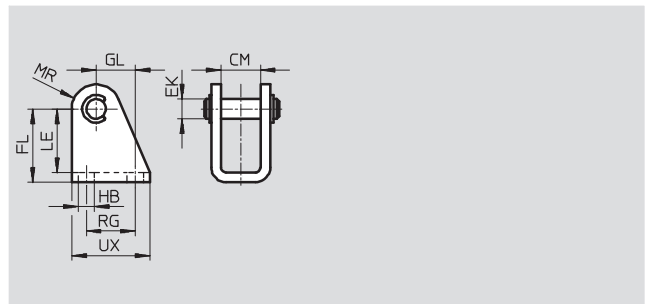

Dimensions and ordering data													
For \varnothing	CM	EK \varnothing	FL	GL	HB \varnothing	LE	MR	RG	UX	CRC ¹⁾	Weight [g]	Part No.	Type
25	16.1	8	30 +0.4/-0.2	16	6.6	26	10	20	32	4	62	161 863	CRLBN-20/25

1) Corrosion resistance class 4 to Festo standard 940 070
Components requiring higher corrosion resistance. Parts used with aggressive media, e.g. food or chemical industry. These applications should be supported with special tests with the media if required

Multi-position cylinders ADNM, standard port pattern



Accessories

Swivel flange SNCB/SNCB-...-R3

Material:
 SNCB: Die-cast aluminium
 SNCB-...-R3: Die-cast aluminium with protective coating, high corrosion protection
 Free of copper, PTFE and silicone

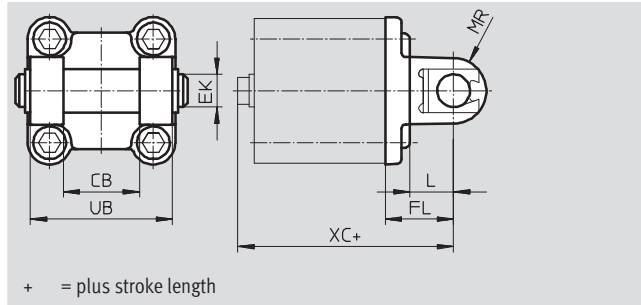
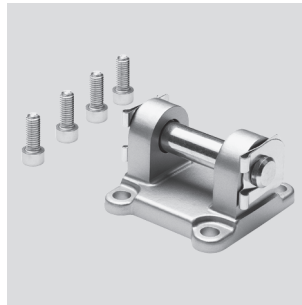

Dimensions and ordering data							
For \varnothing	CB	EK	FL	L	MR	UB	XC
[mm]	H14	\varnothing e8	± 0.2			h14	
40	28	12	25	16	12	52	76
63	40	16	32	21	16	70	89
100	60	20	41	27	20	110	117

For \varnothing	Basic version				R3 – High corrosion protection			
	CRC ¹⁾	Weight [g]	Part No.	Type	CRC ¹⁾	Weight [g]	Part No.	Type
40	2	150	174 391	SNCB-40	3	150	176 945	SNCB-40-R3
63	2	365	174 393	SNCB-63	3	365	176 947	SNCB-63-R3
100	2	925	174 395	SNCB-100	3	925	176 949	SNCB-100-R3

1) Corrosion resistance class 2 to Festo standard 940 070
 Components subject to moderate corrosion stress. Externally visible parts with primarily decorative surface requirements which are in direct contact with a normal industrial environment or media such as coolants or lubricating agents.
 Corrosion resistance class 3 to Festo standard 940 070
 Components requiring higher corrosion resistance. External visible parts in direct contact with industrial atmospheres or media such as solvents and cleaning agents, with a predominantly functional requirement for the surface

Multi-position cylinders ADNM, standard port pattern



Accessories

Trunnion flange ZNCF/CRZNG

Material:

ZNCF: Special steel casting

CRZNG: Electrolytically polished special steel casting

Free of copper, PTFE and silicone

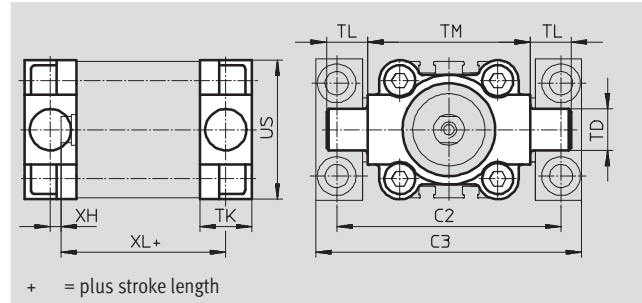
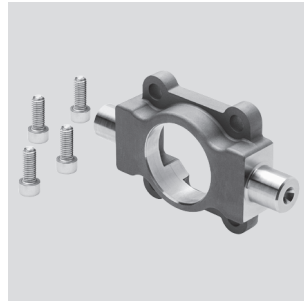

+ = plus stroke length

Dimensions and ordering data

For \varnothing [mm]	C2	C3	TD \varnothing e9	TK	TL	TM	US	XH	XL
40	87	105	16	20	16	63	54	4	55
63	116	136	20	24	20	90	75	4	61
100	164	189	25	38	25	132	110	10	86

For \varnothing [mm]	Basic version				R3 – High corrosion protection			
	CRC ¹⁾	Weight [g]	Part No.	Type	CRC ¹⁾	Weight [g]	Part No.	Type
40	2	240	174 412	ZNCF-40	4	260	161 853	CRZNG-40
63	2	600	174 414	ZNCF-63	4	640	161 855	CRZNG-63
100	2	2030	174 416	ZNCF-100	4	2400	161 857	CRZNG-100

1) Corrosion resistance class 2 to Festo standard 940 070

Components subject to moderate corrosion stress. Externally visible parts with primarily decorative surface requirements which are in direct contact with a normal industrial environment or media such as coolants or lubricating agents.

Corrosion resistance class 4 to Festo standard 940 070

Components requiring higher corrosion resistance. Parts used with aggressive media, e.g. food or chemical industry. These applications should be supported with special tests with the media if required

Trunnion support LNZG

Material:

Trunnion support: Anodised aluminium

Plain bearing: Plastic

Free of copper, PTFE and silicone

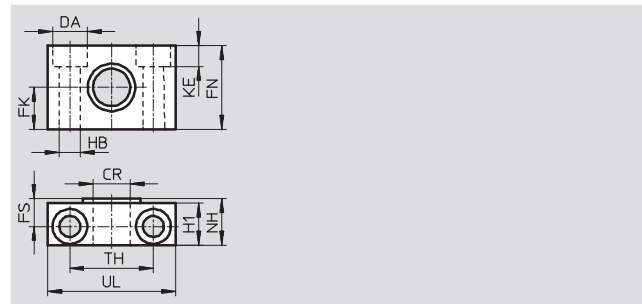
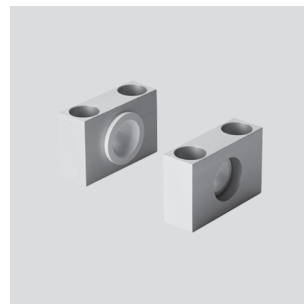

Dimensions and ordering data

For \varnothing [mm]	CR \varnothing D11	DA \varnothing H13	FK \varnothing ± 0.1	FN	FS	H1	HB \varnothing H13	KE	NH	TH ± 0.2	UL	CRC ¹⁾	Weight [g]	Part No.	Type
40	16	15	18	36	12	18	9	9	21	36	55	2	400	32 960	LNZG-40/50
63	20	18	20	40	13	20	11	11	23	42	65	2	480	32 961	LNZG-63/80
100	25	20	25	50	16	24.5	14	13	28.5	50	75	2	960	32 962	LNZG-100/125





1) Corrosion resistance class 2 to Festo standard 940 070



Components subject to moderate corrosion stress. Externally visible parts with primarily decorative surface requirements which are in direct contact with a normal industrial environment or media such as coolants or lubricating agents

Multi-position cylinders ADNM, standard port pattern

Accessories

FESTO

Ordering data – Piston rod attachments				Technical data → Internet: piston rod attachment			
Designation	For Ø	Part No.	Type	Designation	For Ø	Part No.	Type
Rod eye SGS				Rod clevis SGA for rod eye SGS			
	25	9 255	SGS-M8		25	–	
	40	9 262	SGS-M12x1,25		40	10 767	SGA-M12x1,25
	63	9 263	SGS-M16x1,5		63	10 768	SGA-M16x1,5
	100	9 264	SGS-M20x1,5		100	10 769	SGA-M20x1,5
Rod clevis SG				Self-aligning rod coupler FK			
	25	3 111	SG-M8		25	2 062	FK-M8
	40	6 145	SG-M12x1,25		40	6 141	FK-M12x1,25
	63	6 146	SG-M16x1,5		63	6 142	FK-M16x1,5
	100	6 147	SG-M20x1,5		100	6 143	FK-M20x1,5
Coupling piece KSG							
	25	–					
	40	32 964	KSG-M12x1,25				
	63	32 965	KSG-M16x1,5				
	100	32 966	KSG-M20x1,5				

Ordering data – Corrosion and acid resistant piston rod attachments				Technical data → Internet: piston rod attachment			
Designation	For Ø	Part No.	Type	Designation	For Ø	Part No.	Type
Rod eye CRSGS				Rod clevis CRSG			
	25	195 581	CRSGS-M8		25	13 568	CRSG-M8
	40	195 583	CRSGS-M12x1,25		40	13 570	CRSG-M12x1,25
	63	195 584	CRSGS-M16x1,5		63	13 571	CRSG-M16x1,5
	100	195 585	CRSGS-M20x1,5		100	13 572	CRSG-M20x1,5

-  - Note
 Piston rod attachments for cylinders with special thread (variant K5)
 → www.festo.com

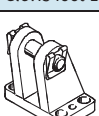
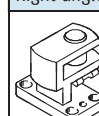

Ordering data – Mounting attachments				Technical data → Internet: mounting attachment			
Designation	For Ø	Part No.	Type	Designation	For Ø	Part No.	Type
Clevis foot LBG for rod eye SGS				Right-angle clevis foot LQG for rod eye SGS			
	25	–			25	–	
	40	31 762	LBG-40		40	31 769	LQG-40
	63	31 764	LBG-63		63	31 771	LQG-63
	100	31 766	LBG-100		100	31 773	LQG-100



Ordering data – One-way flow control valves			Technical data → Internet: grla			
For exhaust air	Connection		Material	Part No.	Type	
	For Ø	For tubing O.D.				
	25, 40	3	Metal design	193 137	GRLA-M5-QS-3-D	
		4			GRLA-M5-QS-4-D	
	63, 100	4			193 143	GRLA-1/8-QS-4-D
		6			193 144	GRLA-1/8-QS-6-D
		8			193 145	GRLA-1/8-QS-8-D

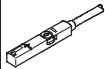

Multi-position cylinders ADN, standard port pattern

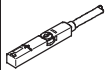
Accessories

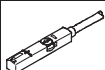
FESTO

Ordering data – Proximity sensors for T-slot, magneto-resistive						Technical data → Internet: smt	
	Type of mounting	Switch output	Electrical connection	Cable length [m]	Part No.	Type	
N/O contact							
	Insertable in the slot from above, flush with cylinder profile	PNP	Cable, 3-wire	2.5	543 867	SMT-8M-PS-24V-K-2,5-OE	
			Plug M8x1, 3-pin	0.3	543 866	SMT-8M-PS-24V-K-0,3-M8D	
			Plug M12x1, 3-pin	0.3	543 869	SMT-8M-PS-24V-K-0,3-M12	
		NPN	Cable, 3-wire	2.5	543 870	SMT-8M-NS-24V-K-2,5-OE	
			Plug M8x1, 3-pin	0.3	543 871	SMT-8M-NS-24V-K-0,3-M8D	
			Plug M12x1, 3-pin	0.3	543 872	SMT-8M-NS-24V-K-0,3-M12	
	Insertable in the slot lengthwise, flush with the cylinder profile	PNP	Cable, 3-wire	2.5	175 436	SMT-8-PS-K-LED-24-B	
			Plug M8x1, 3-pin	0.3	175 484	SMT-8-PS-S-LED-24-B	
N/C contact							
	Insertable in the slot from above, flush with cylinder profile	PNP	Cable, 3-wire	7.5	543 873	SMT-8M-PO-24V-K7,5-OE	

Ordering data – Proximity sensors for T-slot, magnetic reed						Technical data → Internet: sme	
	Type of mounting	Switch output	Electrical connection	Cable length [m]	Part No.	Type	
N/O contact							
	Insertable in the slot from above, flush with cylinder profile	Contacting	Cable, 3-wire	2.5	543 862	SME-8M-DS-24V-K-2,5-OE	
				5.0	543 863	SME-8M-DS-24V-K-5,0-OE	
			Plug M8x1, 3-pin	2.5	543 872	SME-8M-ZS-24V-K-2,5-OE	
				0.3	543 861	SME-8M-DS-24V-K-0,3-M8D	
	Insertable in the slot lengthwise, flush with the cylinder profile	Contacting	Cable, 3-wire	2.5	150 855	SME-8-K-LED-24	
			Plug M8x1, 3-pin	0.3	150 857	SME-8-S-LED-24	
N/C contact							
	Insertable in the slot lengthwise, flush with the cylinder profile	Contacting	Cable, 3-wire	7.5	160 251	SME-8-O-K-LED-24	

Ordering data – Connecting cables					Technical data → Internet: nebu	
	Electrical connection, left	Electrical connection, right	Cable length [m]	Part No.	Type	
	Straight socket, M8x1, 3-pin	Cable, open end, 3-wire	2.5	541 333	NEBU-M8G3-K-2.5-LE3	
			5	541 334	NEBU-M8G3-K-5-LE3	
	Straight socket, M12x1, 5-pin	Cable, open end, 3-wire	2.5	541 363	NEBU-M12G5-K-2.5-LE3	
			5	541 364	NEBU-M12G5-K-5-LE3	
	Angled socket, M8x1, 3-pin	Cable, open end, 3-wire	2.5	541 338	NEBU-M8W3-K-2.5-LE3	
			5	541 341	NEBU-M8W3-K-5-LE3	
	Angled socket, M12x1, 5-pin	Cable, open end, 3-wire	2.5	541 367	NEBU-M12W5-K-2.5-LE3	
			5	541 370	NEBU-M12W5-K-5-LE3	

Multi-position cylinders ADN, standard port pattern



Accessories

Ordering data – Rectangular proximity sensors, pneumatic			Technical data → Internet: smpo	
	Pneumatic connection		Part No.	Type
3/2-way valve, normally closed				
	Female thread M5		178 563	SMPO-8E

Ordering data – Mounting kit for proximity sensors SMPO-8E			Technical data → Internet: smb	
	Assembly		Part No.	Type
	Clamped in T-slot		178 230	SMB-8E

Ordering data – Slot cover for T-slot				
	Assembly	Length	Part No.	Type
	Insertable from above	2x 0.5 m	151 680	ABP-5-S

- 2 - Type discontinued
Available up until 2010

Multi-position cylinders ADVUP

FESTO

Type codes

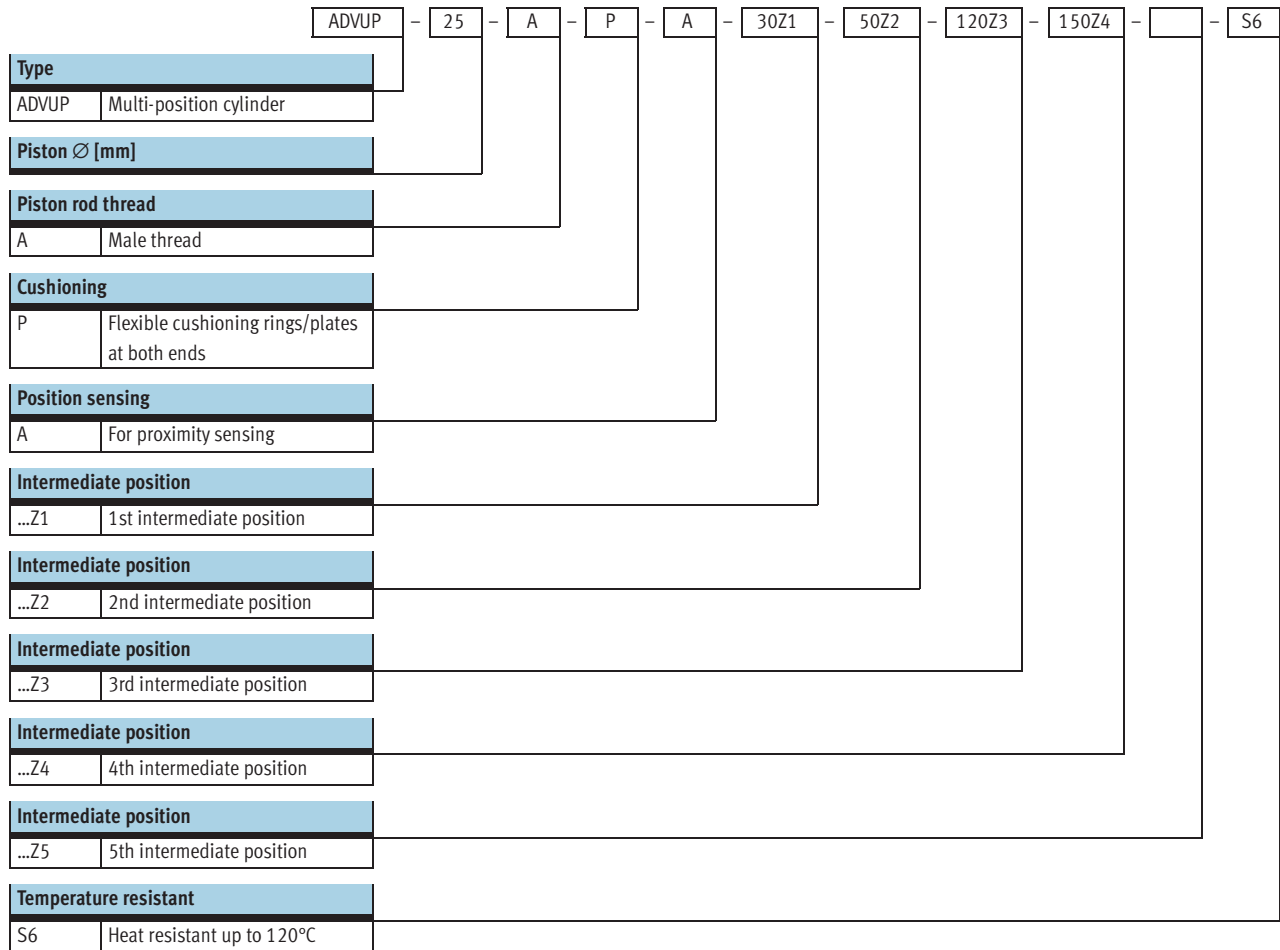

- 7 - Type discontinued
Available up until 2010

Multi-position cylinders ADVUP

Peripherals overview

FESTO

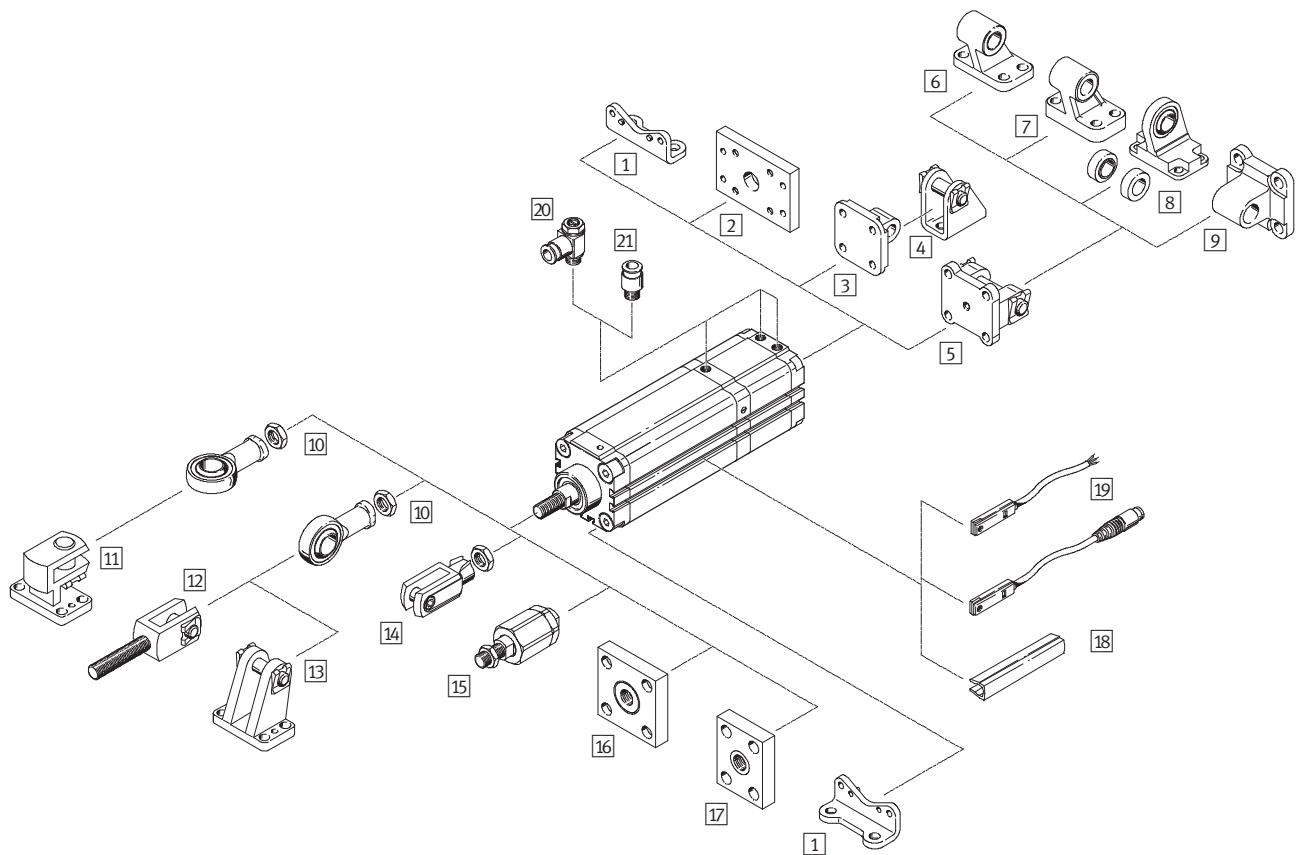

- 7 - Type discontinued
Available up until 2010

Multi-position cylinders ADVUP

Peripherals overview

FESTO

Mounting attachments and accessories					
	Brief description	∅ 25	∅ 40, 63, 100	→ Page/Internet	
1	Foot mounting HUA	for bearing and end caps	■	■	36
2	Flange mounting FUA	for end caps	■	■	37
3	Swivel flange SUA for ∅ 25	for end caps	■	-	38
4	Clevis foot LBN	-	■	-	39
5	Swivel flange SUA for ∅ 40, 63, 100	for end caps	-	■	38
6	Clevis foot LN	-	-	■	39
7	Clevis foot LNG	-	-	■	39
8	Clevis foot LSN	with spherical bearing	-	■	39
9	Swivel flange SNCL	-	-	■	39
10	Rod eye SGS	with spherical bearing	■	■	39
11	Right-angle clevis foot LQG	-	-	■	39
12	Rod clevis SGA	with male thread	■	■	39
13	Clevis foot LBG	-	-	■	39
14	Rod clevis SG	Permits a swivelling movement of the cylinder in one plane	■	■	39
15	Self-aligning rod coupler FK	for compensating radial and angular deviations	■	■	39
16	Coupling piece KSG	for compensating radial deviations	■	■	39
17	Coupling piece KSZ	for cylinders with a non-rotating piston rod to compensate for radial deviations	■	■	39
18	Slot cover ABP-5-S	to protect the sensor cable and keep dirt out of the sensor slots	■	■	40
19	Proximity sensors SME/SMT-8	can be integrated in the cylinder profile barrel	■	■	40
20	One-way flow control valve GRLA/GRLZ	for speed regulation	■	■	41
21	Push-in fitting QS	for connecting compressed air tubing with standard O.D.	■	■	quick star

- 7 - Type discontinued
Available up until 2010

Multi-position cylinders ADVUP

FESTO

Technical data

Function

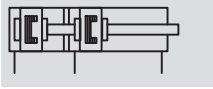

- Ø - Diameter
25, 40, 63, 100

- | - Stroke length
1 ... 2000

- T - www.festo.com

Variants



S6

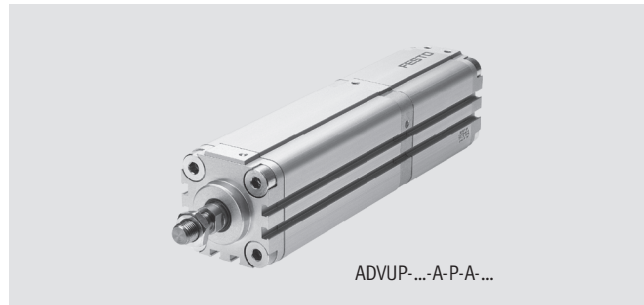
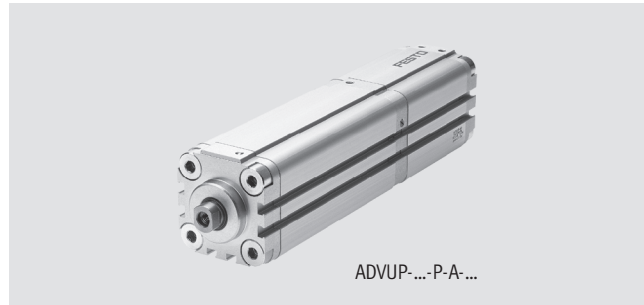

General technical data					
Piston Ø		25	40	63	100
Pneumatic connection		M5	M5	G1/8	G1/4
Piston rod thread	female	M5	M8	M10	M12
	male	M10x1.25	M12x1.25	M16x1.5	M20x1.5
Operating medium	Filtered compressed air, lubricated or unlubricated				
Constructional design	Piston				
	Piston rod				
Cushioning	Flexible cushioning rings/plates at both ends				
Position sensing	For proximity sensing				
Type of mounting	Using internal threads				
	Via accessories				
Mounting position	Any				

Operating pressure [bar]					
Piston Ø		25	40	63	100
2 cylinders		1.1 ... 10		0.9 ... 10	
3 cylinders		1.4 ... 10		1.2 ... 10	
4 cylinders		1.7 ... 10		1.5 ... 10	
5 cylinders		2.0 ... 10		1.8 ... 10	

Ambient conditions		
Multi-position cylinder	Basic version	S6
Ambient temperature ¹⁾	[°C]	-20 ... +80
Corrosion resistance class CRC ²⁾	2	2

1) Note operating range of proximity sensors

2) Corrosion resistance class 2 according to Festo standard 940 070

Components requiring moderate corrosion resistance. Externally visible parts with primarily decorative surface requirements which are in direct contact with a surrounding industrial atmosphere or media such as cooling or lubricating agents

- 7 - Type discontinued
Available up until 2010

Multi-position cylinders ADVUP

Technical data

FESTO

Forces [N] and impact energy [J]				
Piston Ø	25	40	63	100
Theoretical force at 6 bar, advancing	295	754	1,870	4,712
Theoretical force at 6 bar, retracting	247	633	1,682	4,418
Max. impact energy at end positions	0.10	0.52	0.70	1.00

Weights [g]				
Piston Ø	25	40	63	100
2 cylinders				
Product weight at 0 mm stroke	375	825	1,200	5,250
Additional weight per 10 mm stroke	36	70	136	200
Moving load at 0 mm stroke	52	126	268	1,228
Additional load per 10 mm stroke	6	12	21	38
3 cylinders				
Product weight at 0 mm stroke	500	1,100	1,600	7,000
Additional weight per 10 mm stroke	36	69	134	200
Moving load at 0 mm stroke	78	189	402	1,842
Additional load per 10 mm stroke	6	11	19	38
4 cylinders				
Product weight at 0 mm stroke	625	1,375	2,000	8,750
Additional weight per 10 mm stroke	36	69	133	200
Moving load at 0 mm stroke	104	252	536	2,456
Additional load per 10 mm stroke	6	11	18	38
5 cylinders				
Product weight at 0 mm stroke	750	1,650	2,400	10,500
Additional weight per 10 mm stroke	36	69	133	200
Moving load at 0 mm stroke	130	315	670	3,070
Additional load per 10 mm stroke	6	11	18	38

- 7 - Type discontinued
Available up until 2010

Multi-position cylinders ADVUP

Technical data

FESTO

Max. lateral force F_q as a function of projection X

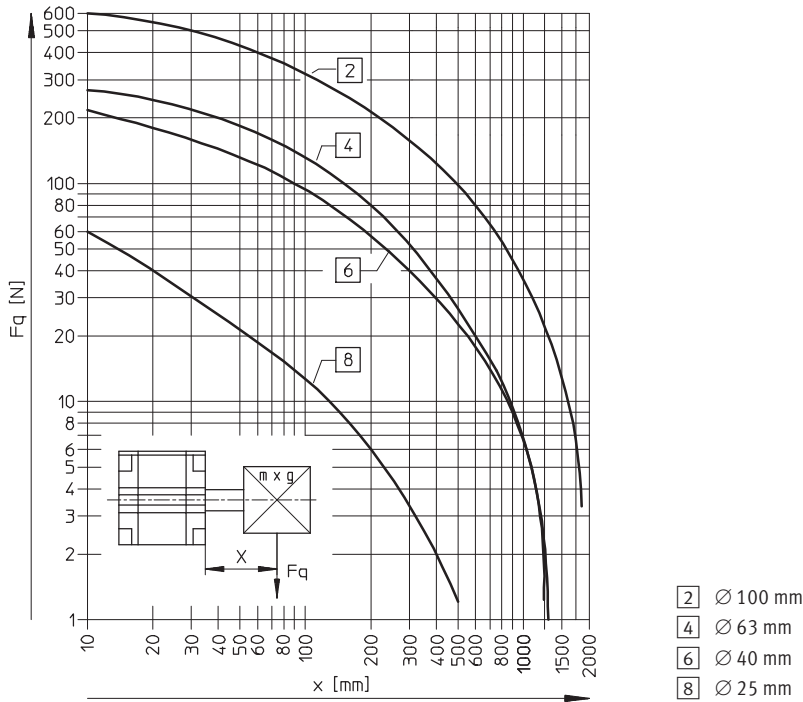

Materials

Sectional view

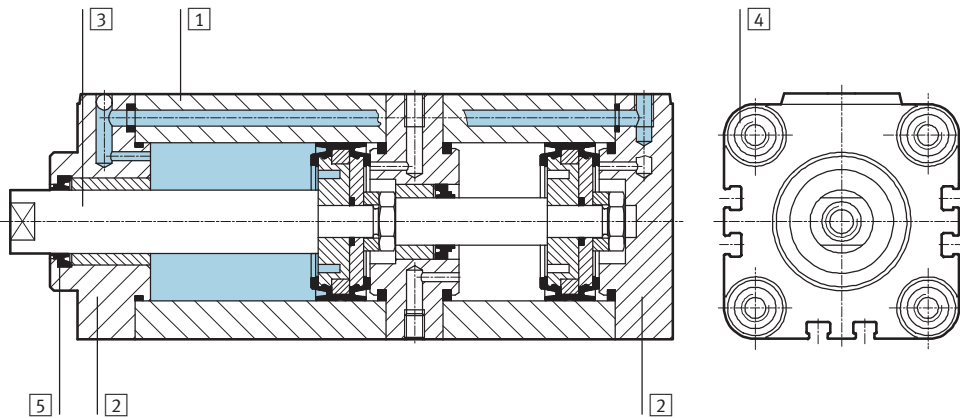

Multi-position cylinder	Basic version	S6
1 Cylinder barrel	Aluminium smooth anodised	Wrought aluminium alloy
2 Bearing end cap	Aluminium smooth anodised	Wrought aluminium alloy
3 Piston rod	Ø 25 High-alloy stainless steel	High-alloy stainless steel
	Ø 40, 63, 100 High-alloy steel	High-alloy steel
4 Flange screws	Tempered steel	Tempered steel
5 Dynamic seals	Polyurethane	Fluorocarbon rubber

- 2 - Type discontinued
Available up until 2010

Multi-position cylinders ADVUP

Technical data

FESTO

Dimensions – Basic cylinder

Download CAD data → www.festo.com

Piston Ø 25 mm

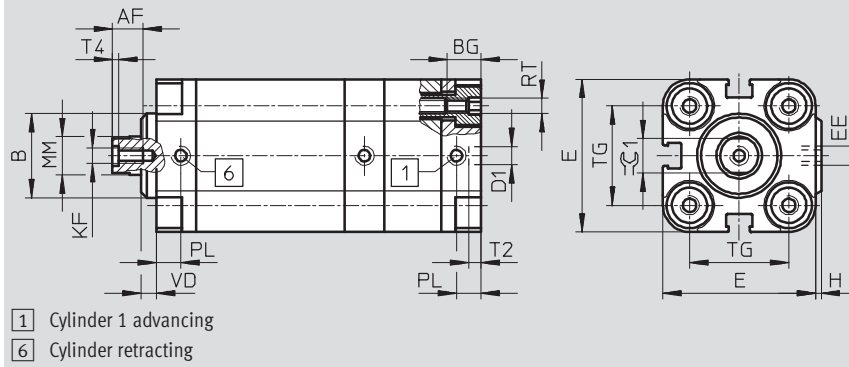

Piston Ø 40, 63, 100 mm

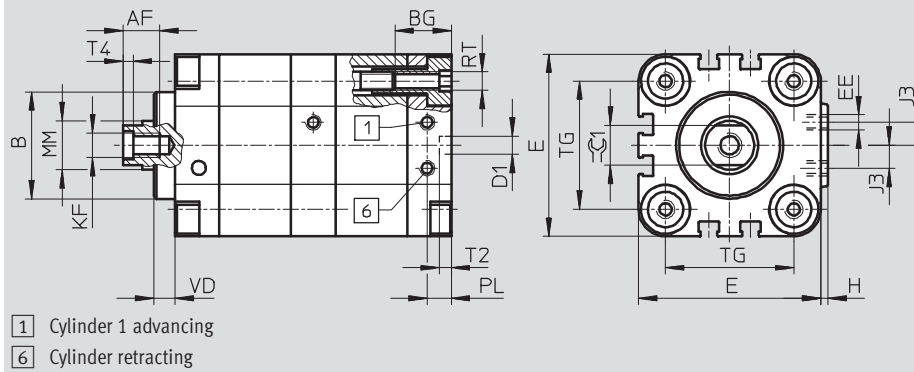

Ø	AF	B Ø	BG	D1 Ø H9	E	EE	H	J3	KF
25	10	22	11	6	40	M5	1.5	-	M5
40	12	35	15	6	60	M5	2.5	7.5	M8
63	16	42	23	8	87	G $\frac{1}{8}$	4	10.5	M10
100	20	55	23	8	128	G $\frac{1}{4}$	5	14.5	M12

Ø	MM Ø	PL	RT	T2	T4	TG	VD	≈C1
				-0.2				h13
25	10	8	M5	4	2	26	4	9
40	16	8	M6	4	3.3	42	7	13
63	20	8	M10	4	4.7	62	11.5	17
100	25	10.5	M10	4	6.1	103	15	22

- 7 - Type discontinued
Available up until 2010

Multi-position cylinders ADVUP

Technical data

FESTO

Dimensions – Variants

Download CAD data → www.festo.com

2 cylinders

with male thread

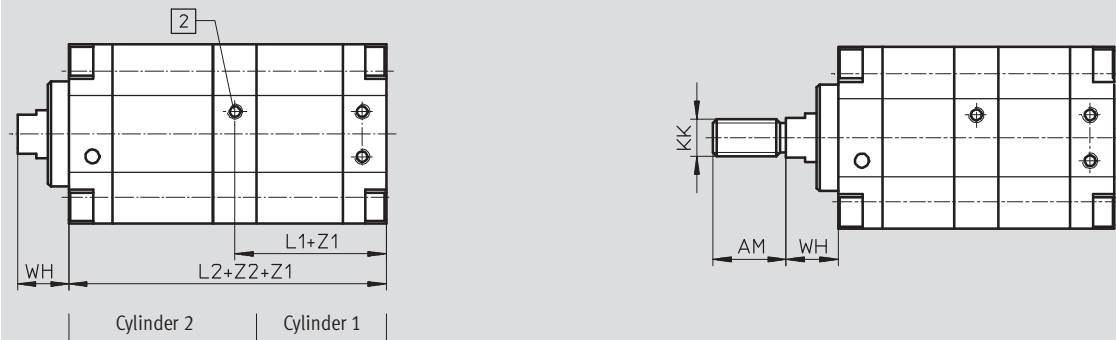

- | | | | |
|---|----------------------|----|----------------------|
| 2 | Cylinder 2 advancing | Z1 | Stroke of cylinder 1 |
| | | Z2 | Stroke of cylinder 2 |

Note

A piston rod with male thread also exists for the ADVUP variants comprising 3, 4 or 5 cylinders.

3 cylinders

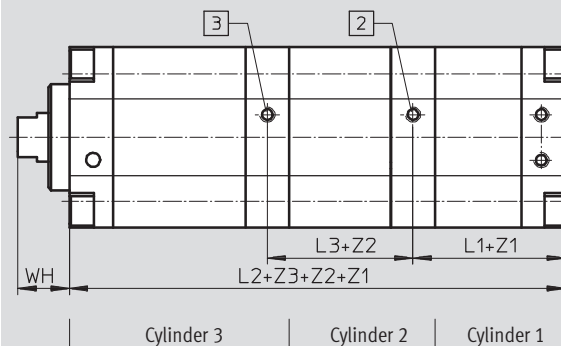

- | | | | |
|---|----------------------|----|----------------------|
| 2 | Cylinder 2 advancing | Z1 | Stroke of cylinder 1 |
| 3 | Cylinder 3 advancing | Z2 | Stroke of cylinder 2 |
| | | Z3 | Stroke of cylinder 3 |

∅ [mm]	AM	KK	L1	L2		L3	WH
				2 cylinders	3 cylinders		
25 ¹⁾	22	M10x1.25	39	78	110.5	32.5	11.5
40 ¹⁾	24	M12x1.25	45.3	90.5	128.5	38	16.5
63 ¹⁾	32	M16x1.5	50.3	100.5	143	42.5	21.5
100 ¹⁾	40	M20x1.5	67.8	135.5	193.5	58	27

1) Nut for piston rod thread included in scope of delivery.

- 2 - Type discontinued
Available up until 2010

Multi-position cylinders ADVUP

Technical data

FESTO

Dimensions – Variants

Download CAD data → www.festo.com

4 cylinders

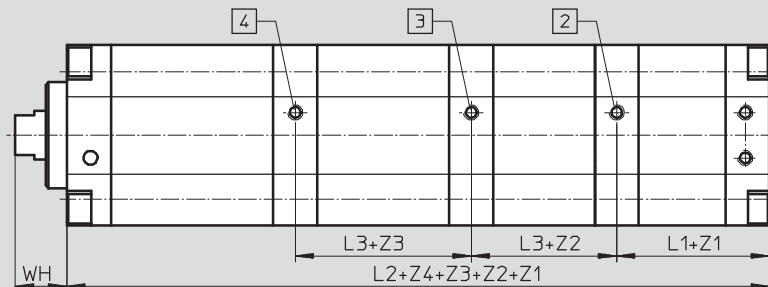

	Cylinder 4	Cylinder 3	Cylinder 2	Cylinder 1
2	Cylinder 2 advancing	Z1	Stroke of cylinder 1	
3	Cylinder 3 advancing	Z2	Stroke of cylinder 2	
4	Cylinder 4 advancing	Z3	Stroke of cylinder 3	
		Z4	Stroke of cylinder 4	

5 cylinders

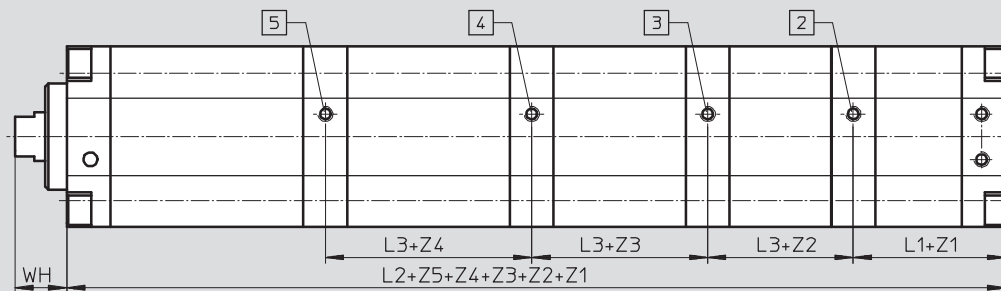

	Cylinder 5	Cylinder 4	Cylinder 3	Cylinder 2	Cylinder 1
2	Cylinder 2 advancing	Z1	Stroke of cylinder 1		
3	Cylinder 3 advancing	Z2	Stroke of cylinder 2		
4	Cylinder 4 advancing	Z3	Stroke of cylinder 3		
5	Cylinder 5 advancing	Z4	Stroke of cylinder 4		
		Z5	Stroke of cylinder 5		

Ø [mm]	L1	L2		L3	WH
		4 cylinders	5 cylinders		
25 ¹⁾	39	143	175.5	32.5	11.5
40 ¹⁾	45.3	166.5	204.5	38	16.5
63 ¹⁾	50.3	185.5	228	42.5	21.5
100 ¹⁾	67.8	251.5	309.5	58	27

1) Nut for piston rod thread included in scope of delivery.

- 7 - Type discontinued
Available up until 2010

Multi-position cylinders ADVUP, female thread

FESTO

Ordering data – Modular product system

M Mandatory data						O Options				
Module No.	Drive system	Size	Cushioning	Position sensing	Mid-position					Temperature-resistant
					1	2	3	4	5	
161 147 161 148 161 149 161 150	ADVUP	25 40 63 100	P	A	...Z1	...Z2	...Z3	...Z4	...Z5	S6
Ordering example 161 147	ADVUP	- 25	- P	- A	- 40Z1	- 95Z2	-	-	-	- S6

Ordering table								
Size	25	40	63	100	Condi- tions	Code		Enter code
M Module No.	161 147	161 148	161 149	161 150				
Drive system	Compact multi-position cylinders					ADVUP		ADVUP
Size	25	40	63	100		-...		
Cushioning	Flexible cushioning rings/plates at both ends					-P		-P
Position sensing	For proximity sensing					-A		-A
1. Mid-position [mm]	1 ... 200	1 ... 300	1 ... 300	1 ... 400	1	-...Z1		
2. Mid-position [mm]	1 ... 300	1 ... 1000	1 ... 1000	1 ... 1000	1 2	-...Z2		
3. Mid-position [mm]	1 ... 300	1 ... 1000	1 ... 1000	1 ... 1000	1 2	-...Z3		
4. Mid-position [mm]	1 ... 300	1 ... 1000	1 ... 1000	1 ... 1000	1 2	-...Z4		
5. Mid-position [mm]	1 ... 300	1 ... 1000	1 ... 1000	1 ... 1000	1 2	-...Z5		
Temperature-resistant	Heat-resistant seals to max. 120° C					-S6		

1 Z1 ... Z5 For the selected mid-positions the following must apply:

The end of the retracted piston rod is the reference point for all mid-positions!

Z1 < Z2 < Z3 < Z4 < Z5: each subsequent mid-position must be larger than the one that precedes it.

Maximum overall length (sum of all individual strokes):

Z1 + Z2 + Z3 + Z4 + Z5 ≤ 1000 mm at Ø 25

Z1 + Z2 + Z3 + Z4 + Z5 ≤ 2000 mm at Ø 40 ... 100.

2 Z2 ... Z5 Max. permissible stroke except for the last position (visible piston rod) in mm:

200 mm for Ø 25;

300 mm for Ø 40, 63;

400 mm for Ø 100.

Transfer order code

ADVUP - - P - A - - - - - - -

- 2 - Type discontinued
Available up until 2010

Multi-position cylinders ADVUP, male thread

FESTO

Ordering data – Modular product system

M Mandatory data						O Options					
Module No.	Drive system	Size	Thread type	Cushioning	Position sensing	Mid-position					Temperature-resistant
						1	2	3	4	5	
197 277 197 278 197 279 197 280	ADVUP	25 40 63 100	A	P	A	...Z1	...Z2	...Z3	...Z4	...Z5	S6
Ordering example 197 278	ADVUP	- 25	- A	- P	- A	- 20Z1	-	-	-	-	-

Ordering table								
Size	25	40	63	100	Condi- tions	Code	Enter code	
M Module No.	197 277	197 278	197 279	197 280				
Drive system	Compact multi-position cylinders					ADVUP		ADVUP
Size	25	40	63	100		-...		
Thread type	Male thread					-A		-A
Cushioning	Flexible cushioning rings/plates at both ends					-P		-P
Position sensing	For proximity sensing					-A		-A
1. Mid-position [mm]	1 ... 200	1 ... 300	1 ... 300	1 ... 400	1	-...Z1		
2. Mid-position [mm]	1 ... 300	1 ... 1000	1 ... 1000	1 ... 1000	1 2	-...Z2		
3. Mid-position [mm]	1 ... 300	1 ... 1000	1 ... 1000	1 ... 1000	1 2	-...Z3		
4. Mid-position [mm]	1 ... 300	1 ... 1000	1 ... 1000	1 ... 1000	1 2	-...Z4		
5. Mid-position [mm]	1 ... 300	1 ... 1000	1 ... 1000	1 ... 1000	1 2	-...Z5		
Temperature-resistant	Heat-resistant seals to max. 120° C					-S6		

- 1 Z1 ... Z5 For the selected mid-positions the following must apply:
The end of the retracted piston rod is the reference point for all mid-positions!
Z1 < Z2 < Z3 < Z4 < Z5: each subsequent mid-position must be larger than the one that precedes it.
Maximum overall length (sum of all individual strokes):
Z1 + Z2 + Z3 + Z4 + Z5 ≤ 1000 mm at Ø 25
Z1 + Z2 + Z3 + Z4 + Z5 ≤ 2000 mm at Ø 40 ... 100.

- 2 Z2 ... Z5 Max. permissible stroke except for the last mid-position (visible piston rod) in mm:
200 mm for Ø 25;
300 mm for Ø 40, 63;
400 mm for Ø 100.

Transfer order code

- 7 - Type discontinued
Available up until 2010

Multi-position cylinders ADVUP

Accessories

FESTO

Foot mounting HUA

Material:
Galvanised steel
Free of copper, PTFE and silicone

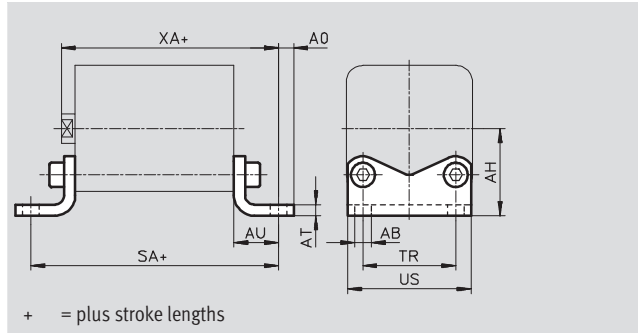

Dimensions and ordering data										
For \varnothing	AB \varnothing	AH	AO	AT	AU	SA				TR
						2 cylinders ¹⁾	3 cylinders ²⁾	4 cylinders ³⁾	5 cylinders ⁴⁾	
25	6.6	29	6.25	4	16	110	142.5	175	207.5	26
40	9	40.5	8.25	5	20	130.5	168.5	206.5	244.5	42
63	11	56.5	11.75	6	27	154.5	197	239.5	282	62
100	13.5	81	11.75	8	33	201.5	259.5	317.5	375.5	103

For \varnothing	US	XA				CRC ⁵⁾	Weight [g]	Part No.	Type
		2 cylinders ¹⁾	3 cylinders ²⁾	4 cylinders ³⁾	5 cylinders ⁴⁾				
25	38	105.5	138	170.5	203	2	90	157 311	HUA-25
40	58	127	165	203	241	2	201	157 313	HUA-40
63	85	149	191.5	234	276.5	2	550	157 315	HUA-63
100	126	195.5	253.5	311.5	369.5	2	1,050	157 317	HUA-100

1) plus stroke length X1+X2

2) plus stroke length X1+X2+X3

3) plus stroke length X1+X2+X3+X4

4) plus stroke length X1+X2+X3+X4+X5

5) Corrosion resistance class 2 according to Festo standard 940 070

Components requiring moderate corrosion resistance. Externally visible parts with primarily decorative surface requirements which are in direct contact with a surrounding industrial atmosphere or media such as cooling or lubricating agents

- 2 - Type discontinued
Available up until 2010

Multi-position cylinders ADVUP

Accessories

FESTO

Flange mounting FUA

Material:
Clear anodised aluminium

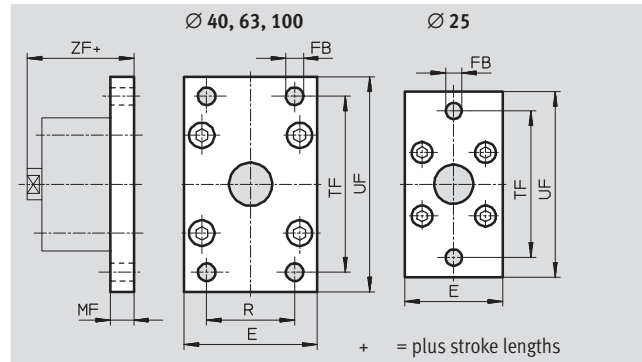
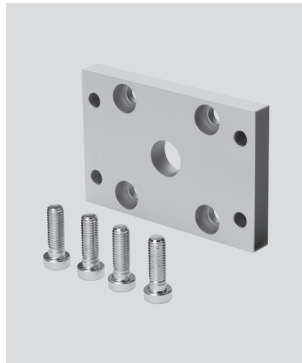

Dimensions and ordering data

For Ø	E	FB Ø	MF	R	TF	UF	ZF				CRC ⁵⁾	Weight [g]	Part No.	Type
							2 cylinders ¹⁾	3 cylinders ²⁾	4 cylinders ³⁾	5 cylinders ⁴⁾				
25	40	6.6	10	-	60	76	99.5	132	164.5	197	2	87	157 301	FUA-25
40	60	9	10	36	82	102	117	155	193	231	2	180	157 303	FUA-40
63	87	9	15	50	110	130	137	179.5	222	264.5	2	550	157 305	FUA-63
100	128	14	15	75	163	190	177.5	235.5	293.5	351.5	2	1 035	157 307	FUA-100

1) plus stroke length X1+X2

2) plus stroke length X1+X2+X3

3) plus stroke length X1+X2+X3+X4

4) plus stroke length X1+X2+X3+X4+X5

5) Corrosion resistance class 2 according to Festo standard 940 070

Components requiring moderate corrosion resistance. Externally visible parts with primarily decorative surface requirements which are in direct contact with a surrounding industrial atmosphere or media such as cooling or lubricating agents

- 7 - Type discontinued
Available up until 2010

Multi-position cylinders ADVUP

Accessories

FESTO

Swivel flange SUA for piston \varnothing 25 mm

Material:
Anodised aluminium
Free of copper, PTFE and silicone

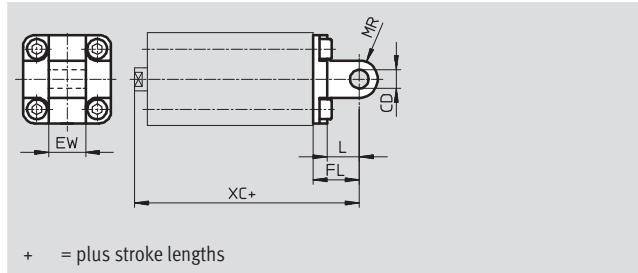
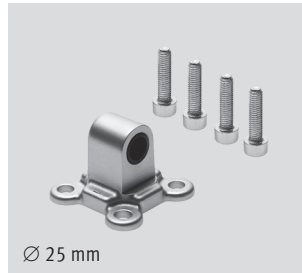

for piston \varnothing 40, 63, 100 mm

Material:
Anodised aluminium
Free of copper, PTFE and silicone

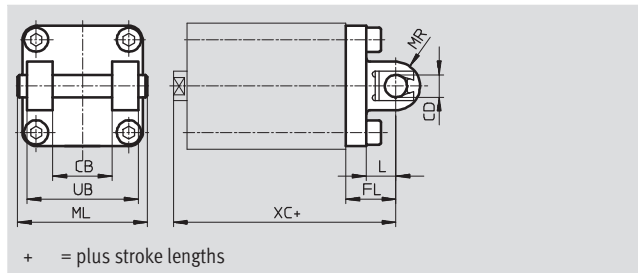

Dimensions and ordering data

For \varnothing	CB	CD \varnothing	EW	FL	L	ML	MR	UB
25	-	8	16	20	14	-	8	-
40	28	12	-	25	16	62	12	52
63	40	16	-	32	21	82	16	70
100	60	20	-	41	26	126	20	110

For \varnothing	XC				Weight [g]	Part No.	Type
	2 cylinders ¹⁾	3 cylinders ²⁾	4 cylinders ³⁾	5 cylinders ⁴⁾			
25	109.5	142	174.5	207	86	157 321	SUA-25
40	132	170	208	246	320	157 323	SUA-40
63	154	196.5	239	281.5	760	157 325	SUA-63
100	203.5	261.5	319.5	377.5	1 900	157 327	SUA-100

- 1) plus stroke length X1+X2
- 2) plus stroke length X1+X2+X3
- 3) plus stroke length X1+X2+X3+X4
- 4) plus stroke length X1+X2+X3+X4+X5

For \varnothing	Max. stroke length
25	50 mm
40	100 mm
63	100 mm
100	150 mm

-  - Note



The maximum stroke length may not be exceeded when combining cylinders and swivel flanges.



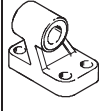

- 7 - Type discontinued
Available up until 2010

Multi-position cylinders ADVUP

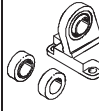
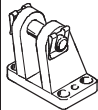
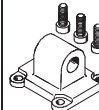
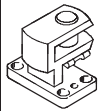
Accessories

FESTO

Ordering data – Mounting attachments				Technical data → Internet: mounting attachment			
Designation	For Ø	Part No.	Type	Designation	For Ø	Part No.	Type
Clevis foot LBN				Clevis foot LNG			
	25	6 059	LBN-20/25		40	33 891	LNG-40
					63	33 893	LNG-63
					100	33 895	LNG-100
Clevis foot LN				Clevis foot LSN			
	40	5 148	LN-40		40	5 562	LSN-40
	63	5 150	LN-63		63	5 564	LSN-63
	100	5 152	LN-100		100	5 566	LSN-100
Clevis foot LBG				Swivel flange SNCL			
	40	31 762	LBG-40		40	174 405	SNCL-40
	63	31 764	LBG-63		63	174 407	SNCL-63
	100	31 766	LBG-100		100	174 409	SNCL-100
Right-angle clevis foot LQG							
	25	–	–				
	40	31 769	LQG-40				
	63	31 771	LQG-63				
	100	31 773	LQG-100				

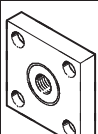
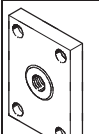

Ordering data – Piston rod attachments				Technical data → Internet: piston rod attachment			
Designation	For Ø	Part No.	Type	Designation	For Ø	Part No.	Type
Rod eye SGS				Rod clevis SGA			
	25	9 261	SGS-M10x1,25		25	32 954	SGA-M10x1,25
	40	9 262	SGS-M12x1,25		40	10 767	SGA-M12x1,25
	63	9 263	SGS-M16x1,5		63	10 768	SGA-M16x1,5
	100	9 264	SGS-M20x1,5		100	10 769	SGA-M20x1,5
Rod clevis SG				Self-aligning rod coupler FK			
	25	6 144	SG-M10x1,25		25	6 140	FK-M10x1,25
	40	6 145	SG-M12x1,25		40	6 141	FK-M12x1,25
	63	6 146	SG-M16x1,5		63	6 142	FK-M16x1,5
	100	6 147	SG-M20x1,5		100	6 143	FK-M20x1,5
Coupling piece KSG				Coupling piece KSZ			
	25	32 963	KSG-M10x1,25		25	36 125	KSZ-M10x1,25
	40	32 964	KSG-M12x1,25		40	36 126	KSZ-M12x1,25
	63	32 965	KSG-M16x1,5		63	36 127	KSZ-M16x1,5
	100	32 966	KSG-M20x1,5		100	36 128	KSZ-M20x1,5



- 7 - Type discontinued
Available up until 2010

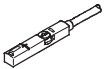

Multi-position cylinders ADVUP

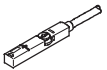
Accessories

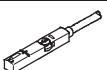
FESTO

Ordering data – Proximity sensors for T-slot, magneto-resistive						Technical data → Internet: smt	
	Type of mounting	Switch output	Electrical connection	Cable length [m]	Part No.	Type	
N/O contact							
	Insertable in the slot from above, flush with cylinder profile	PNP	Cable, 3-wire	2.5	543 867	SMT-8M-PS-24V-K-2,5-OE	
			Plug M8x1, 3-pin	0.3	543 866	SMT-8M-PS-24V-K-0,3-M8D	
			Plug M12x1, 3-pin	0.3	543 869	SMT-8M-PS-24V-K-0,3-M12	
		NPN	Cable, 3-wire	2.5	543 870	SMT-8M-NS-24V-K-2,5-OE	
Plug M8x1, 3-pin	0.3		543 871	SMT-8M-NS-24V-K-0,3-M8D			
	Insertable in the slot lengthwise, flush with the cylinder profile	PNP	Cable, 3-wire	2.5	175 436	SMT-8-PS-K-LED-24-B	
			Plug M8x1, 3-pin	0.3	175 484	SMT-8-PS-S-LED-24-B	
N/C contact							
	Insertable in the slot from above, flush with cylinder profile	PNP	Cable, 3-wire	7.5	543 873	SMT-8M-PO-24V-K7,5-OE	

Ordering data – Proximity sensors for T-slot, magnetic reed						Technical data → Internet: sme	
	Type of mounting	Switch output	Electrical connection	Cable length [m]	Part No.	Type	
N/O contact							
	Insertable in the slot from above, flush with cylinder profile	Contacting	Cable, 3-wire	2.5	543 862	SME-8M-DS-24V-K-2,5-OE	
				5.0	543 863	SME-8M-DS-24V-K-5,0-OE	
			Plug M8x1, 3-pin	2.5	543 872	SME-8M-ZS-24V-K-2,5-OE	
				0.3	543 861	SME-8M-DS-24V-K-0,3-M8D	
	Insertable in the slot lengthwise, flush with the cylinder profile	Contacting	Cable, 3-wire	2.5	150 855	SME-8-K-LED-24	
			Plug M8x1, 3-pin	0.3	150 857	SME-8-S-LED-24	
N/C contact							
	Insertable in the slot lengthwise, flush with the cylinder profile	Contacting	Cable, 3-wire	7.5	160 251	SME-8-O-K-LED-24	

Ordering data – Connecting cables					Technical data → Internet: nebu	
	Electrical connection, left	Electrical connection, right	Cable length [m]	Part No.	Type	
	Straight socket, M8x1, 3-pin	Cable, open end, 3-wire	2.5	541 333	NEBU-M8G3-K-2.5-LE3	
			5	541 334	NEBU-M8G3-K-5-LE3	
	Straight socket, M12x1, 5-pin	Cable, open end, 3-wire	2.5	541 363	NEBU-M12G5-K-2.5-LE3	
			5	541 364	NEBU-M12G5-K-5-LE3	
	Angled socket, M8x1, 3-pin	Cable, open end, 3-wire	2.5	541 338	NEBU-M8W3-K-2.5-LE3	
			5	541 341	NEBU-M8W3-K-5-LE3	
	Angled socket, M12x1, 5-pin	Cable, open end, 3-wire	2.5	541 367	NEBU-M12W5-K-2.5-LE3	
			5	541 370	NEBU-M12W5-K-5-LE3	



Ordering data – Slot cover for T-slot				
	Mounting	Length	Part No.	Type
	Insertable from above	2x 0.5 m	151 680	ABP-5-S

- 2 - Type discontinued
Available up until 2010

Multi-position cylinders ADVUP

Accessories

FESTO

Ordering data – One-way flow control valves				Technical data → Internet: grl			
	Connection		Material	Part No.	Type		
	Thread	For tubing OD					
For exhaust air							
	M5	3	Metal design	193 137	GRLA-M5-QS-3-D		
		4		193 138	GRLA-M5-QS-4-D		
		6		193 139	GRLA-M5-QS-6-D		
	G $\frac{1}{8}$	3		193 142	GRLA- $\frac{1}{8}$ -QS-3-D		
		4		193 143	GRLA- $\frac{1}{8}$ -QS-4-D		
		6		193 144	GRLA- $\frac{1}{8}$ -QS-6-D		
		8		193 145	GRLA- $\frac{1}{8}$ -QS-8-D		
	G $\frac{1}{4}$	6		193 146	GRLA- $\frac{1}{4}$ -QS-6-D		
		8		193 147	GRLA- $\frac{1}{4}$ -QS-8-D		
		10		193 148	GRLA- $\frac{1}{4}$ -QS-10-D		
	For supply air						
		M5		3	Metal design	193 153	GRLZ-M5-QS-3-D
4			193 154	GRLZ-M5-QS-4-D			
6			193 155	GRLZ-M5-QS-6-D			
G $\frac{1}{8}$		3	193 156	GRLZ- $\frac{1}{8}$ -QS-3-D			
		4	193 157	GRLZ- $\frac{1}{8}$ -QS-4-D			
		6	193 158	GRLZ- $\frac{1}{8}$ -QS-6-D			
		8	193 159	GRLZ- $\frac{1}{8}$ -QS-8-D			

Adapter kits DPNC/DPNG, standard port pattern



Technical data

Adapter kit DPNC

for standard cylinder DNCB, DNC,
standard cylinder ADN Ø125,
compact cylinder ADVU Ø125 and
short-stroke cylinder ADVC

Material:

Flange: Wrought aluminium alloy;

threaded pins, hex nuts:

Galvanised steel

Free of copper, PTFE and silicone

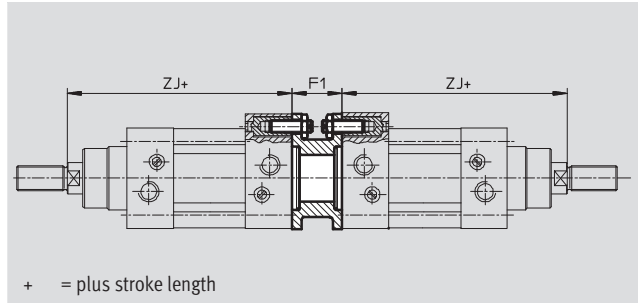
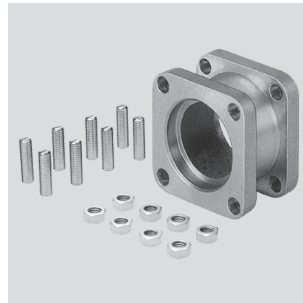

+ = plus stroke length

Note
The maximum overall stroke length may not be exceeded when combining cylinders and the adapter kit.

Dimensions and ordering data							
For Ø	F1	ZJ	Max. overall stroke length [mm]	CRC ¹⁾	Weight [g]	Part No.	Type
32	27	120	1,000	2	85	174 418	DPNC-32
40	27	135	1,000	2	115	174 419	DPNC-40
50	32	143	1,000	2	210	174 420	DPNC-50
63	28	158	1,000	2	360	174 421	DPNC-63
80	38	174	1,000	2	620	174 422	DPNC-80
100	38	189	1,000	2	1,190	174 423	DPNC-100
125	48	225	1,000	2	1,600	174 424	DPNC-125

1) Corrosion resistance class 2 according to Festo standard 940 070
Components requiring moderate corrosion resistance. Externally visible parts with primarily decorative surface requirements which are in direct contact with a surrounding industrial atmosphere or media such as cooling or lubricating agents

Adapter kit DPNG

For standard cylinders DNG

Material:

Flange: Wrought aluminium alloy;

threaded pins, hex nuts: Galvanised steel

Free of copper, PTFE and silicone

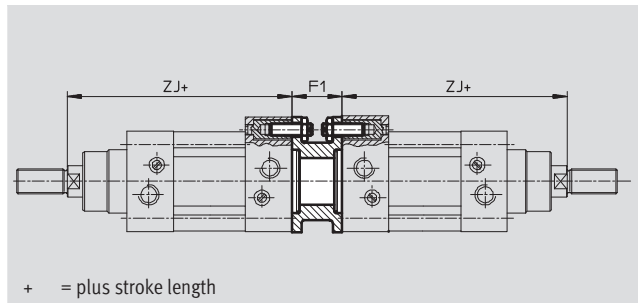
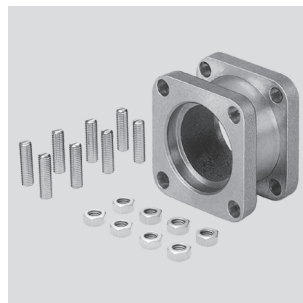

+ = plus stroke length

Note
The maximum overall stroke length may not be exceeded when combining cylinders and the adapter kit.

Dimensions and ordering data							
For Ø	F1	ZJ	Max. overall stroke length [mm]	CRC ¹⁾	Weight [g]	Part No.	Type
32	27	120	1,000	2	85	159 485	DPNG-32
40	27	135	1,000	2	115	159 486	DPNG-40
50	32	143	1,000	2	210	159 487	DPNG-50
63	28	158	1,000	2	360	159 488	DPNG-63
80	38	174	1,000	2	620	159 489	DPNG-80
100	38	189	1,000	2	1,190	159 490	DPNG-100

1) Corrosion resistance class 2 according to Festo standard 940 070
Components requiring moderate corrosion resistance. Externally visible parts with primarily decorative surface requirements which are in direct contact with a surrounding industrial atmosphere or media such as cooling or lubricating agents

Adapter kits DPNA/DPVU

Technical data

 **New**





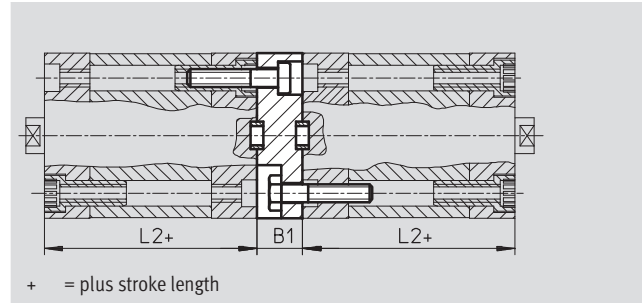





Adapter kit DPNA
for standard cylinder ADN

Material:
Flange: Aluminium
Screws: Galvanised steel
Free of copper, PTFE and silicone



 **Note**

The maximum overall stroke length may not be exceeded when combining cylinders and the adapter kit.

Dimensions and ordering data						
For Ø	B1	L2	Max. overall stroke length [mm]	CRC ¹⁾	Part No.	Type
12	13	35	600	2	537 263	DPNA-12 
16	13	35	600	2	537 264	DPNA-16 
20	13	37	600	2	537 265	DPNA-20 
25	13	39	600	2	537 266	DPNA-25 
32	15	44	800	2	537 267	DPNA-32 
40	15	45	800	2	537 268	DPNA-40 
50	15	45	800	2	537 269	DPNA-50 
63	15	49	800	2	537 270	DPNA-63 
80	17	54	1,000	2	537 271	DPNA-80 
100	19,5	67	1,000	2	537 272	DPNA-100 

1) Corrosion resistance class 2 according to Festo standard 940 070
Components requiring moderate corrosion resistance. Externally visible parts with primarily decorative surface requirements which are in direct contact with a surrounding industrial atmosphere or media such as cooling or lubricating agents

Adapter kit DPVU
for compact cylinder ADVU

Material:
Flange: Aluminium
Screws: Galvanised steel
Free of copper, PTFE and silicone

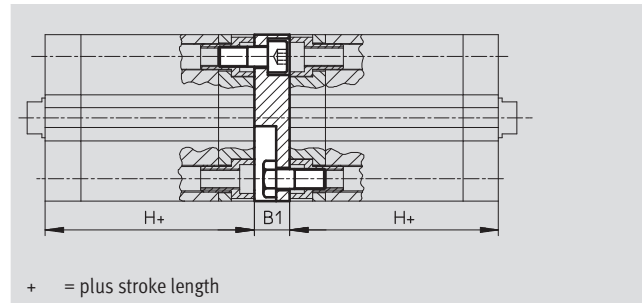

 **Note**

The maximum overall stroke length may not be exceeded when combining cylinders and the adapter kit.

Dimensions and ordering data						
For Ø	B1	H	Max. overall stroke length [mm]	CRC ¹⁾	Weight [g]	Part No. Type
12/16	12,5	38	400	2	22	161 194 DPVU-12/16
20	12,5	38	400	2	36	161 195 DPVU-20
25	13	39,5	400	2	44	161 196 DPVU-25
32	14,5	44,5	600	2	90	161 197 DPVU-32
40	14,5	45,5	600	2	137	161 198 DPVU-40
50	14,5	45,5	600	2	177	161 199 DPVU-50
63	14,5	50	600	2	308	161 200 DPVU-63
80	16,5	56	800	2	495	161 201 DPVU-80
100	19,5	66,5	800	2	859	161 202 DPVU-100

1) Corrosion resistance class 2 according to Festo standard 940 070
Components requiring moderate corrosion resistance. Externally visible parts with primarily decorative surface requirements which are in direct contact with a surrounding industrial atmosphere or media such as cooling or lubricating agents