

Toothed belt axes ELGR

FESTO



Key features

At a glance

General	Properties	Range of applications
<ul style="list-style-type: none"> • Optimum price/performance ratio • Ready-to-install unit for quick and easy design • High reliability thanks to tested service life of 5000 km • Complete module for a simple and space-saving solution for end-position sensing 	<ul style="list-style-type: none"> • Plain-bearing guide <ul style="list-style-type: none"> – For small loads – Restricted operating behaviour with torque load – Guide not backlash-free 	<ul style="list-style-type: none"> • Recirculating ball bearing guide <ul style="list-style-type: none"> – For medium loads – Very good operating behaviour with torque load – Backlash-free guide (preloaded guide elements)
		<ul style="list-style-type: none"> • Pick & place with payloads of up to 15 kg • Positioning and handling with low process forces • Actuation of guard doors in processing machines

Modular axis system with open motor interface → page 6

- Variable strokes
- Two guide variants
- Axial kits for servo and stepper motors
- The motor position can be freely selected on 4 sides and can be changed at any time

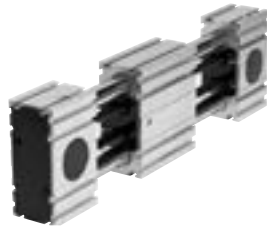

Optimised Motion Series (OMS) – Package solution with motor and motor controller → page 18

A package that makes positioning easier than ever before. The Optimised Motion Series is as easy to handle as a pneumatic cylinder, but with the functionality of an electric drive.



Simple selection

- Easy sizing and selection using cycle time charts
- No special knowledge of electric drive technology required

Ordering and logistics

- All the necessary individual parts under a single part number
- Motors pre-assembled on the axis mechanism

Quick to configure

- Parameterisation and commissioning via web server/browser
- Parameterise up to 7 freely definable positions directly on the PC

For simple positioning tasks

Toothed belt axis ELGR



Controller CMMO-ST



Key features

Combination options within the Optimised Motion Series (OMS)

Electric cylinder EPCO on toothed belt axis ELGR

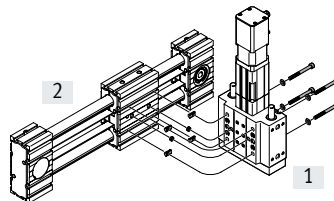
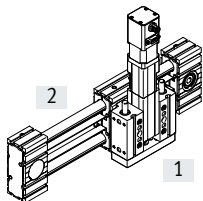

Size		Accessories			
[1] EPCO	[2] ELGR	Slot nut	Centring sleeve	Screw	Washer
16	35	NST-3-M3 (x4)	ZBH-7 (x2)	M3x10 (x4)	–
25	45	NST-5-M5 (x4)	ZBH-7 (x2)	M5x50 (x4)	DIN125-A5.3 (x4)
40	55	NST-5-M5 (x4)	ZBH-7 (x2)	M5x65 (x4)	DIN125-A5.3 (x4)

Rotary drive ERMO on electric cylinder EPCO

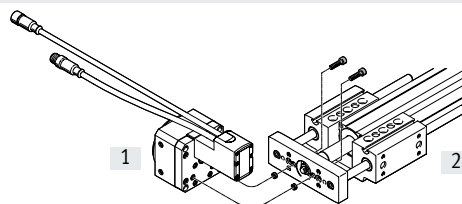
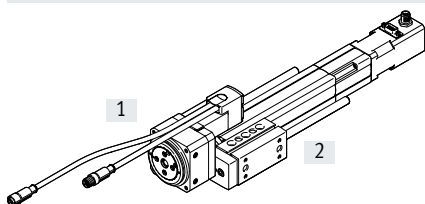

Size		Accessories	
[1] ERMO	[2] EPCO	Centring sleeve	Screw
12	16	ZBH-7 (x2)	M4x16 (x2)
16	25	ZBH-7 (x2)	M5x18 (x2)
25	40	ZBH-7 (x2)	M5x20 (x2)

Rotary drive ERMO on mini slide DGSL

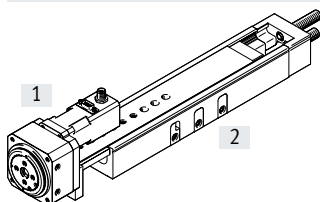

When combining ERMO-12 with DGSL-12, the proximity sensor SIEN cannot be used as a homing sensor for ERMO.

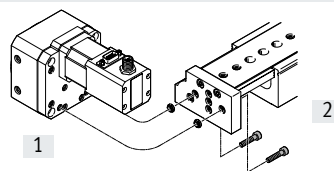

Size		Accessories	
[1] ERMO	[2] DGSL	Centring sleeve	Screw
12	12	ZBH-7 (x2)	M4x18 (x2)
25	20	ZBH-9-7 (x2)	M5x22 (x2)
25	25	ZBH-9-7 (x2)	M5x22 (x2)

Rotary drive ERMO on mini slide EGSL

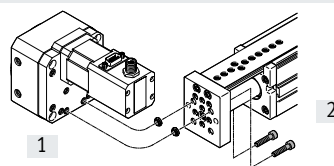
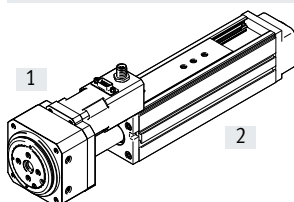

Size		Accessories	
[1] ERMO	[2] EGSL	Centring sleeve	Screw
12	35	ZBH-7 (x2)	M4x12 (x2)
16	45	ZBH-7 (x2)	M5x12 (x2)
25	55	ZBH-7 (x2)	M5x14 (x2)
32	55	ZBH-7 (x2)	M5x14 (x2)

Key features

Combination options within the Optimised Motion Series (OMS)

Electric cylinder EPCO on electric cylinder EPCO, horizontal

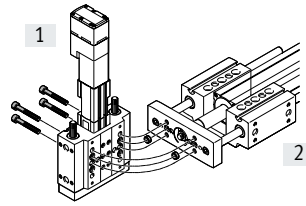
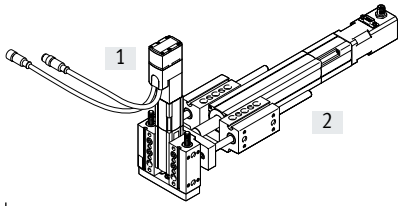

Size		Accessories	
[1] EPCO	[2] EPCO	Centring sleeve	Screw
16	25	ZBH-9 (x2)	M6x40 (x4)
25	40	ZBH-9 (x2)	M6x55 (x4)

Electric cylinder EPCO on electric cylinder EPCO, vertical

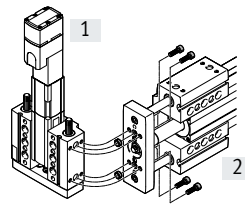
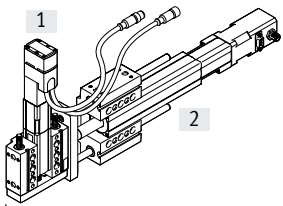

Size		Accessories	
[1] EPCO	[2] EPCO	Centring sleeve	Screw
16	25	ZBH-9 (x2)	M5x18 (x4)
25	40	ZBH-9 (x2)	M5x22 (x4)

Mini slide DGSL on electric cylinder EPCO

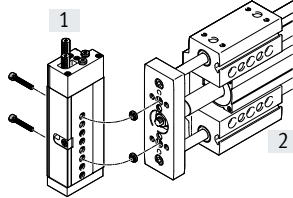
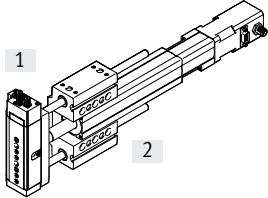

Size		Accessories	
[1] DGSL	[2] EPCO	Centring sleeve	Screw
8 (40 mm) ¹⁾	16	ZBV-9-7 (x2)	M4x16 (x2)
10 (30mm) ¹⁾	25	ZBV-9-7 (x2)	M4x20 (x2)
12 (40mm) ¹⁾	40	ZBV-9-7 (x2)	M5x20 (x2)

1) Minimum stroke

Key features

Characteristic values of the axes

The specifications shown in the table are maximum values.

The precise values for each of the variants can be found in the relevant data sheet.



Note

Engineering software

PositioningDrives

www.festo.com

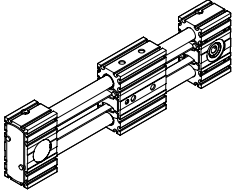
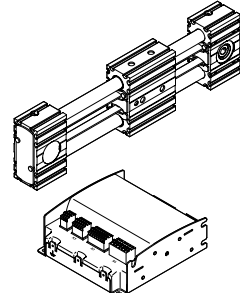
Version	Size	Working stroke [mm]	Speed [m/s]	Repetition accuracy [mm]	Feed force [N]	Guide characteristics Forces and torques					→ Page
						Fy [N]	Fz [N]	Mx [Nm]	My [Nm]	Mz [Nm]	
Toothed belt axis ELGR											
	35	50 ... 800	3	±0.1	50	50	50	2.5	20	20	6
	45	50 ... 1000	3	±0.1	100	100	100	5	40	40	
	55	50 ... 1500	3	±0.1	350	300	300	15	124	124	
Toothed belt axis ELGR in combination with Optimised Motion series (OMS)											
	35	50 ... 800 ¹⁾	1.1	±0.1	50	20	20	2.5	20	20	18
	45	50 ... 1000 ¹⁾	1.1	±0.1	100	50	50	5	40	40	
	55	50 ... 1500 ¹⁾	0.35	±0.1	350	90	90	15	124	124	

1) Only standard strokes can be ordered → page 32

Type codes

001	Series	
ELGR	Linear axis	
002	Drive system	
TB	Toothed belt	
003	Guide	
004	Size	
35	35	
45	45	
55	55	
005	Stroke	
100	100	
200	200	
300	300	
400	400	
500	500	
600	600	
800	800	
1000	1000	
1200	1200	
1500	1500	
...	100 ... 1500	
006	Stroke reserve	
007	Slide design	
	Standard	
L	Slide, long	
008	Additional slide	
	None	
ZR	1 slide right	
ZL	1 slide left	
ZB	Additional slide 1x left, 1x right	
009	Motor type	
	Without motor	
ST	Stepper motor ST	
010	Measuring unit	
	None	
E	Encoder	
011	Brake	
	None	
B	With brake	
012	Cable outlet direction	
AT	Top	
AD	Underneath	
AL	Left	
AR	Right	

013	Motor position	
	Standard	
FR	Front right	
FL	Front left	
RR	Rear right	
RL	Rear left	
014	Proximity sensor, inductive, slot 8, PNP, N/C contact, cable 7.5 m [units]	
...	1 ... 6	
015	Proximity sensor, inductive, slot 8, PNP, N/O contact, cable 7.5 m [units]	
...	1 ... 6	
016	Mounting slot cover, 2x, 500 mm [units]	
...	1 ... 50	
017	Slot nut for mounting slot [units]	
...	1 ... 99	
018	Drive shaft [units]	
...	1 ... 4	
019	Profile mounting	
...	1 ... 2	
020	Connecting cable to motor controller	
	None	
1.5E	1.5 m, suitable for energy chains, straight plug	
2.5E	2.5 m, suitable for energy chains, straight plug	
5E	5 m, suitable for energy chains, straight plug	
7E	7 m, suitable for energy chains, straight plug	
10E	10 m, suitable for energy chains, straight plug	
021	Controller type	
	None	
C5	CMMO, 5 A	
022	Bus protocol/activation	
	None	
DIO	Digital I/O interface	
LK	IO-Link®	
PP	Pulse sequence interface	
023	Switching input/output	
	None	
P	PNP	
N	NPN	
024	Operating instructions	
	With operating instructions	
DN	No operating instructions	

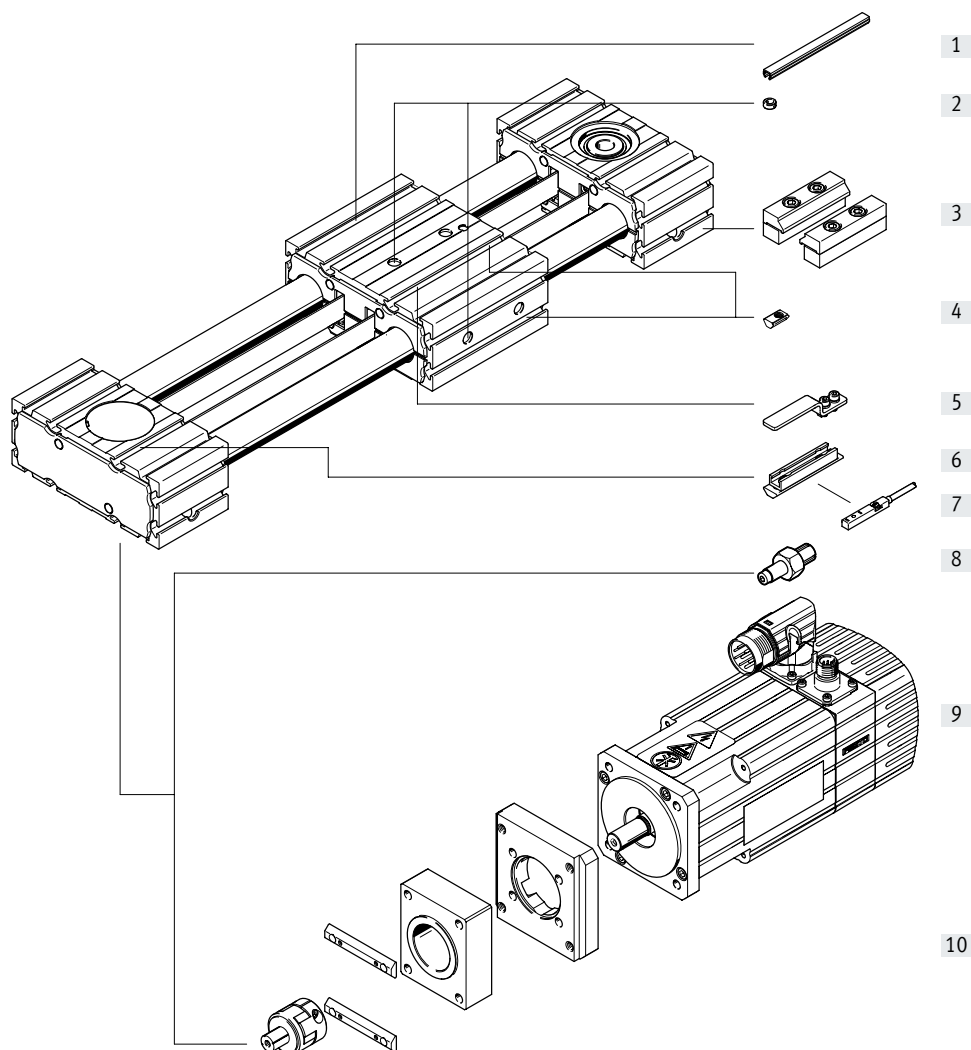

Peripherals overview

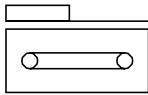

Accessories			
	Type/order code	Description	→ Page/Internet
[1]	Slot cover NC	<ul style="list-style-type: none"> For protecting against contamination 	37
[2]	Centring sleeve ZBH	<ul style="list-style-type: none"> For centring loads and attachments on the slide 2 centring sleeves included in the scope of delivery of the axis 	37
[3]	Profile mounting MA	For mounting the axis on the bearing cap	36
[4]	Slot nut NM	For mounting attachments	37
[5]	Switch lug SA, SB	For sensing the slide position	36
[6]	Sensor bracket SA, SB	Adapter for mounting the inductive proximity sensors on the axis	36
[7]	Proximity sensor, T-slot SA, SB	<ul style="list-style-type: none"> Inductive proximity sensor, for T-slot 1 switch lug and 1 sensor bracket are included in the scope of delivery with the order code SA, SB 	38
[8]	Drive shaft EA	<ul style="list-style-type: none"> Can, if required, be used as an alternative interface No drive shaft is required for the axis/motor combinations → Page 32 	37
[9]	Motor EMME, EMMS	Motors specially matched to the axis, with or without brake	32
[10]	Axial kit EAMM	For axial motor mounting (comprises: coupling, coupling housing and motor flange)	32
-	Connecting cable NEBU	For proximity sensor (order code SA and SB)	38

Data sheet



-  Size
35 ... 55
-  Stroke length
50 ... 1500 mm
-  www.festo.com

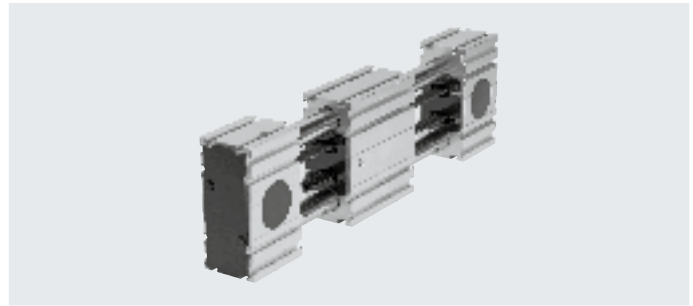

General technical data		35	45	55
Size		35	45	55
Design		Electromechanical linear axis with toothed belt		
Guide		Recirculating ball bearing guide		
		Plain-bearing guide		
Mounting position		Any		
Working stroke	[mm]	50 ... 800	50 ... 1000	50 ... 1500
Max. feed force F_x	[N]	50	100	350
Max. no-load torque	[Nm]	0.1	0.2	0.4
Max. driving torque	[Nm]	0.46	1.24	5
Max. no-load resistance to shifting	[N]	10.8	16.1	27.9
Max. speed				
Recirculating ball bearing guide	[m/s]	3		
Plain-bearing guide	[m/s]	1		
Max. acceleration ¹⁾	[m/s ²]	50		
Repetition accuracy	[mm]	±0.1		

1) The max. acceleration is dependent on the payload, the driving torque and the max. feed force → page 11

Operating and environmental conditions			
Ambient temperature			
Recirculating ball bearing guide	[°C]	-10 ... +50	
Plain-bearing guide	[°C]	0 ... +40	
Degree of protection		IP20	
Duty cycle	[%]	100	

Weight [kg]		35	45	55
Recirculating ball bearing guide				
Basic weight with 0 mm stroke ¹⁾				
Standard slide		1.5	3.2	5.4
Long slide		1.9	4.3	7.4
Additional weight per 1000 mm stroke		2.5	5.0	7.8
Moving mass		0.5	1.1	1.9
Slide				
Standard slide		0.5	1.0	1.8
Long slide		0.8	1.7	3.0
Additional slide		0.4	0.9	1.7

1) Incl. slide

Data sheet

Weight [kg]			
Size	35	45	55
Plain-bearing guide			
Basic weight with 0 mm stroke ¹⁾			
Standard slide	1.4	3.1	5.1
Long slide	1.9	4.3	7.3
Additional weight per 1000 mm stroke	2.5	5.0	7.8
Moving mass	0.4	0.9	1.5
Slide			
Standard slide	0.4	0.9	1.5
Long slide	0.7	1.6	2.8
Additional slide	0.3	0.7	1.3

1) Incl. slide

Toothed belt			
Size	35	45	55
Pitch [mm]	2	3	3
Expansion ¹⁾ [%]	0.094	0.08	0.21
Width [mm]	10	15	19.3
Effective diameter [mm]	18.46	24.83	28.65
Feed constant [mm/rev.]	58	78	90

1) At max. feed force

Mass moment of inertia			
Size	35	45	55
J_0			
Standard slide [kg mm ²]	40.26	155.13	360.48
Long slide [kg mm ²]	66.50	271.52	638.74
J_S per metre stroke [kg mm ² /m]	0.26	1.06	1.88
J_L per kg payload [kg mm ² /Kg]	85.19	154.13	205.21
J_W additional slide [kg mm ²]	36.75	136.55	301.92

The mass moment of inertia J_A of the entire axis is calculated as follows:

$$J_A = J_0 + K \times J_W + J_S \times \text{working stroke [m]} + J_L \times m_{\text{payload [kg]}}$$

K = Number of additional slides

Materials

Sectional view

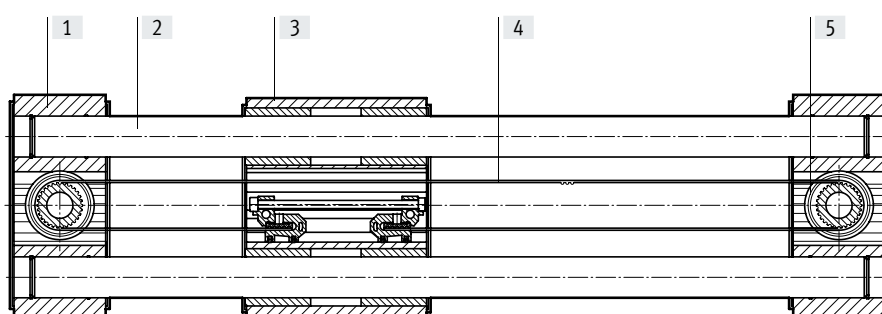

Axis	
[1] Bearing cap, profile	Anodised wrought aluminium alloy
[2] Guide rods	Hardened and hard-chromium plated tempered steel
[3] Slide, profile	Anodised wrought aluminium alloy
[4] Toothed belt	Polychloroprene with glass cord and nylon coating
[5] Belt pulley	High-alloy stainless steel
Note on materials	RoHS-compliant
	Contains paint-wetting impairment substances

Data sheet

Characteristic load values

The indicated forces and torques refer to the centre of the guide. The point of application of force is the point where the centre of the guide and the longitudinal centre of the slide intersect. These values must not be exceeded during dynamic operation. Special attention must be paid to the deceleration phase.

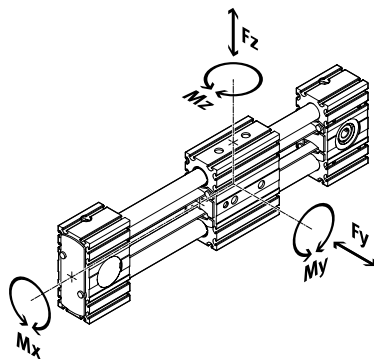

If the axis is subjected to several of the indicated forces and torques simultaneously, the following equation must be satisfied in addition to the indicated maximum loads:

Calculating the load comparison factor:

$$f_v = \frac{|F_{y1}|}{F_{y2}} + \frac{|F_{z1}|}{F_{z2}} + \frac{|M_{x1}|}{M_{x2}} + \frac{|M_{y1}|}{M_{y2}} + \frac{|M_{z1}|}{M_{z2}} \leq 1$$

F_1/M_1 = dynamic value

F_2/M_2 = maximum value

Permissible forces and torques for a service life of 5000 km

Guide Size	Plain-bearing guide			Recirculating ball bearing guide		
	35	45	55	35	45	55
$F_{y_{max}}, F_{z_{max}}$ [N]	50	100	300	50	100	300
Standard slide						
$M_{x_{max}}$ [Nm]	1	2.5	5	2.5	5	15
$M_{y_{max}}$ [Nm]	4	8	16	8	16	48
$M_{z_{max}}$ [Nm]	4	8	16	8	16	48
Long slide						
$M_{x_{max}}$ [Nm]	1	2.5	5	2.5	5	15
$M_{y_{max}}$ [Nm]	10	20	40	20	40	124
$M_{z_{max}}$ [Nm]	10	20	40	20	40	124

Service life

The service life of the guide depends on the load. To provide a rough indication of the service life of the guide, the graph below plots the load comparison factor f_v against the service life.

These values are only theoretical. You must consult your local contact person at Festo for load comparison factors f_v greater than 1.5.

Load comparison factor f_v as a function of service life

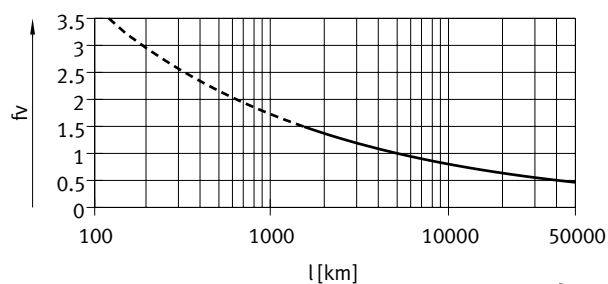

Example:

A user wants to move an X kg load. Using the above formula gives a value of 1.5 for the load comparison factor f_v . According to the graph, the guide would have a service life of approx. 1500 km. Reducing the acceleration reduces the M_z and M_y values. A load comparison factor of 1 now gives a service life of 5000 km.

Note

Engineering software
PositioningDrives
www.festo.com

Data sheet

Max. load with flat mounting position

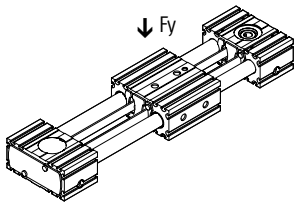

The characteristic curves in the graph correspond to the max. recommended deflection of 0.5 mm. In this case, the axis can no longer support the maximum load past a certain stroke length.

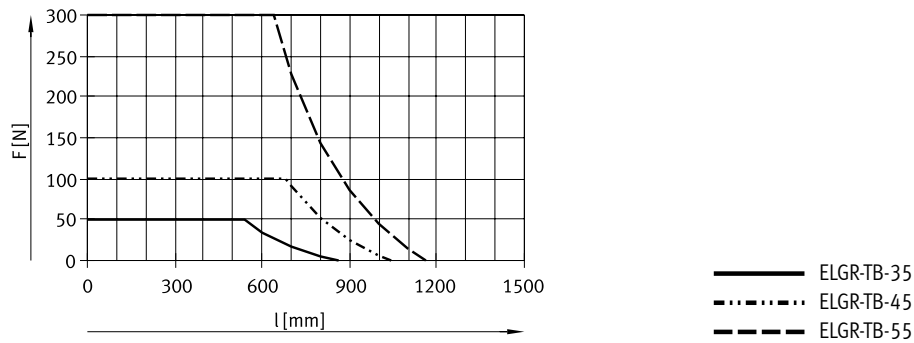

Max. acceleration a as a function of payload m

ELGR-35

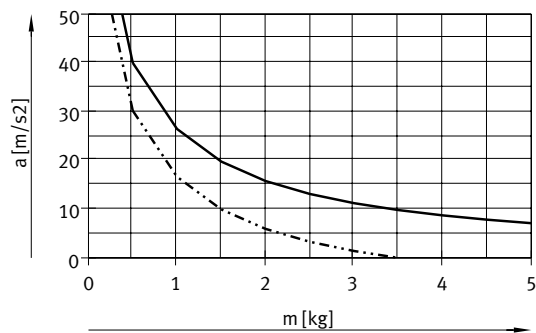

ELGR-45

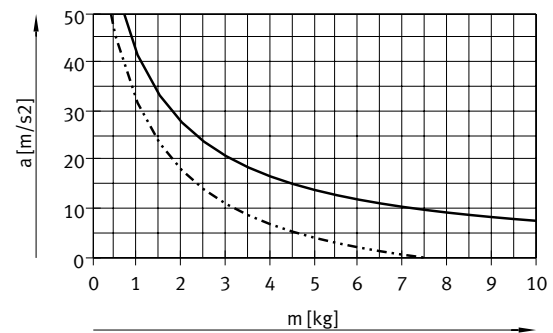

ELGR-55

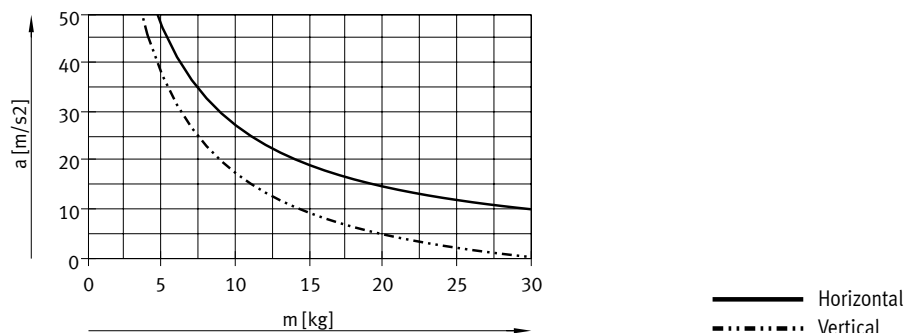

Data sheet

Feed force F_x as a function of input torque M

ELGR-35

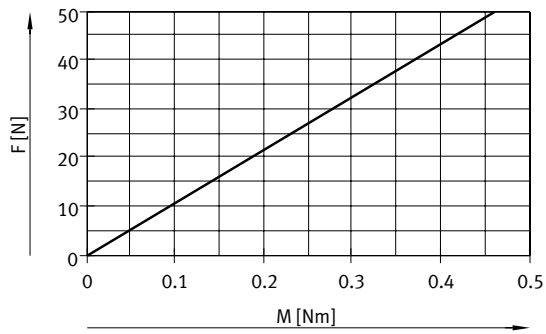

ELGR-45

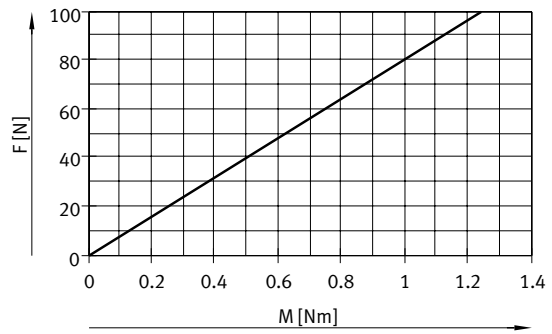

ELGR-55

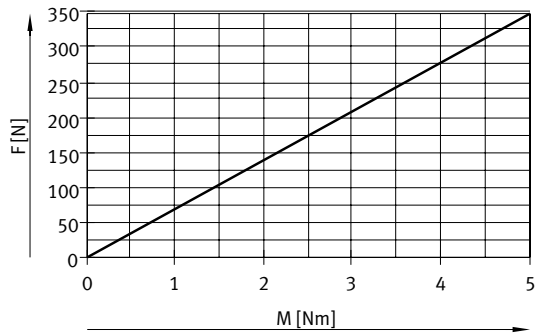

Speed v as a function of rotational speed n

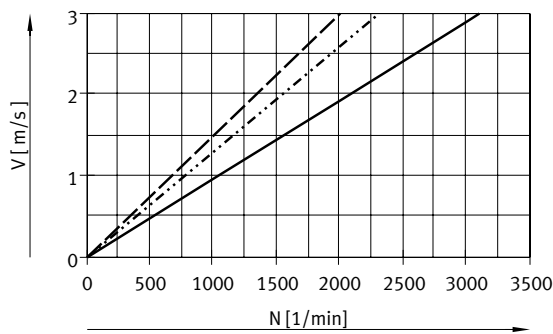

- ELGR-TB-35
- ⋯ ELGR-TB-45
- - - ELGR-TB-55

Data sheet

Minimum nominal stroke

For variant with additional slide ELGR-...-ZR/ZL-ZB

Size	35		45		55		
ELGR-	ZR/ZL	ZB	ZR/ZL	ZB	ZR/ZL	ZB	
Min. nominal stroke	[mm]	126	202	146	242	166	282

Stroke reserve

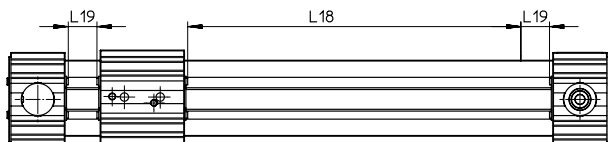

L18 = Nominal stroke
L19 = Stroke reserve

- The stroke reserve is a safety distance from the mechanical end position and is not used in normal operation
 - The sum of the nominal stroke and 2x stroke reserve must not exceed the maximum permissible working stroke
 - The stroke reserve length can be freely selected
 - The stroke reserve is defined via the "stroke reserve" characteristic in the modular product system.
- Example:**
 Type ELGR-TB-45-500-20H-...
 Nominal stroke = 500 mm
 2x stroke reserve = 40 mm
 Working stroke = 540 mm
 (540 mm = 500 mm + 2 x 20 mm)

Working stroke reduction

For standard slide or long slide with additional slide ELGR-...-ZR/ZL/ZB

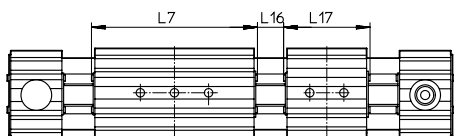

L7 = Slide length
L16 = Distance between the two slides
L17 = Additional slide length

- For a toothed belt axis with additional slide, the working stroke is reduced by the length of the additional slide and the distance between the two slides
 - If the long slide variant L is ordered, the additional slide is not extended
- Example:**
 Type ELGR-TB-35-500-...-ZR
 Working stroke = 500 mm
 L16 = 10 mm
 L7, L17 = 76 mm
 Working stroke with additional slide = 414 mm
 (500 mm - 10 mm - 76 mm)

Dimensions – Additional slide

Size	35		45		55	
Length L17	[mm]	76	96	116		
Distance between the slides L16	[mm]	≥ 0				

2nd moment of area

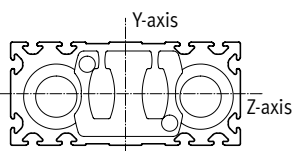

Size	35		45		55	
ly	[mm ⁴]	4.19x10 ³	17.95x10 ³	41.18x10 ³		
lz	[mm ⁴]	3.77x10 ³	15.71x10 ³	38.35x10 ³		

Recommended deflection limits

Adherence to a maximum deflection of 0.5 mm is recommended so as not to impair the functional performance of the axes. Greater deformation can result in increased friction, greater wear and reduced service life.

Data sheet

Dimensions

Download CAD data → www.festo.com

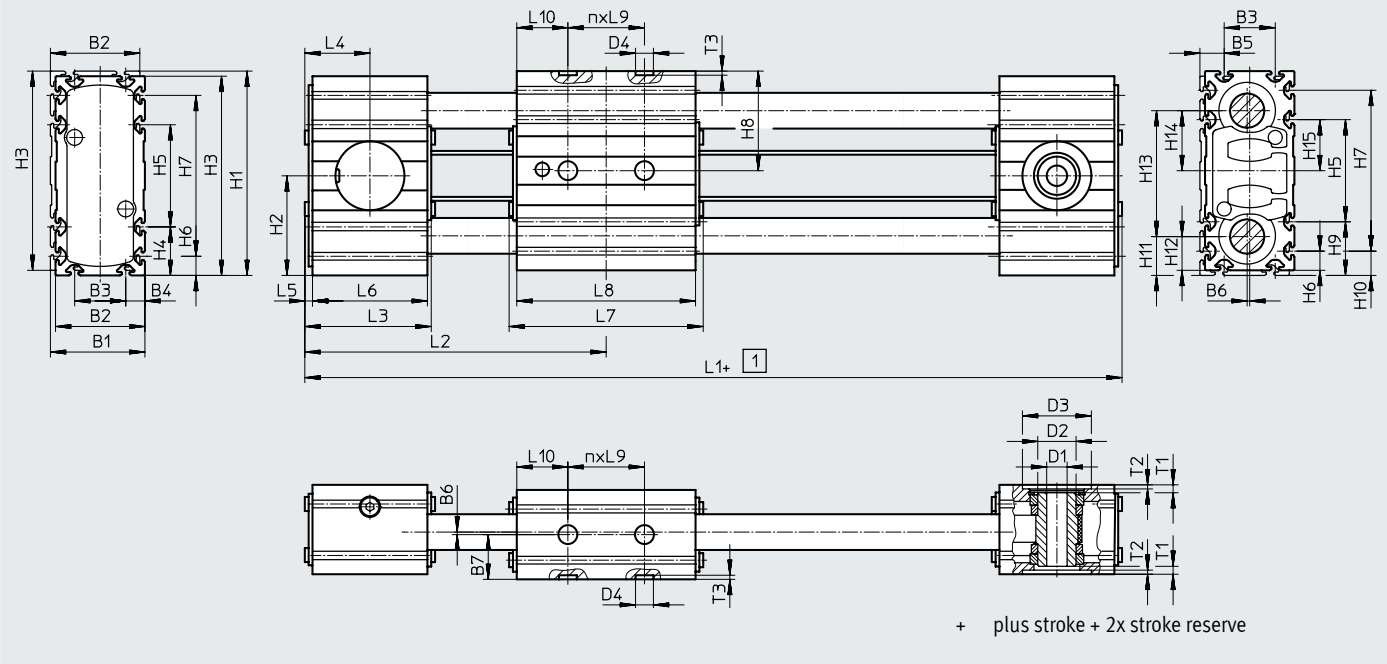

Profile

ELGR-35

ELGR-45

ELGR-55

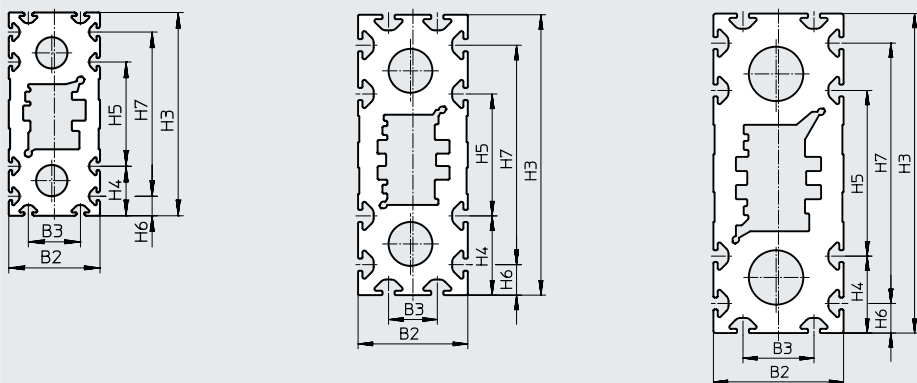

Size	B1	B2	B3	B4	B5	B6	B7	D1 ∅	D2 ∅	D3 ∅	D4 ∅	H1	H2	H3	H4	H5	H6
35	37	35	20	7.5	9.5	1	17.5	8	15	27	7	80	39	78	19	40	7.5
45	47	45	20	12.5	14.5		22.5	10	20	38		117	57.5	115	32.5	50	12.5
55	57	55	30	12.5	14.5		27.5	16	25	48		137	67.5	135	32.5	70	12.5

Size	H7	H8	H9	H10	H11	H12	H13	H14	H15	L3	L4	L5	L6	L9	T1	T2	T3 +0.1
35	63	39	21	9.5	15.5	13.5	49	23.5	20	51	25.5	3	45	30	3.1	1.6	1.6
45	90	57.5	34.5	14.5	23	21	71	34.5	25	60	30		54	40	3	1.7	
55	110	67.5	34.5	14.5	25.5	23.5	86	42	35	62	31		56	40	4.5	2	

Size ELGR...	L1		L2		L7		L8		L10		n	
		-L		-L		-L		-L		-L		-L
35	178	248	89	124	76	146	70	140	20	40	1	2
45	219	309	108	153	96	186	90	180	25	50	1	2
55	243	353	120	175	116	226	110	220	35	70	1	2

Data sheet

Ordering data – Standard version

Key features:

- Stroke reserve: 0 mm
- Standard slide

Size	Stroke [mm]	Part no.	Type
35	100	8083770	ELGR-TB-35-100-0H
	200	8083771	ELGR-TB-35-200-0H
	300	8083772	ELGR-TB-35-300-0H
	400	8083773	ELGR-TB-35-400-0H
	500	8083774	ELGR-TB-35-500-0H
	600	8083775	ELGR-TB-35-600-0H
45	100	8083776	ELGR-TB-45-100-0H
	200	8083777	ELGR-TB-45-200-0H
	300	8083778	ELGR-TB-45-300-0H
	400	8083779	ELGR-TB-45-400-0H
	500	8083780	ELGR-TB-45-500-0H
	600	8083781	ELGR-TB-45-600-0H
	800	8083782	ELGR-TB-45-800-0H
	1000	8083783	ELGR-TB-45-1000-0H
55	100	8083784	ELGR-TB-55-100-0H
	200	8083785	ELGR-TB-55-200-0H
	300	8083786	ELGR-TB-55-300-0H
	400	8083787	ELGR-TB-55-400-0H
	500	8083788	ELGR-TB-55-500-0H
	600	8083789	ELGR-TB-55-600-0H
	800	8083790	ELGR-TB-55-800-0H
	1000	8083791	ELGR-TB-55-1000-0H
	1200	8083792	ELGR-TB-55-1200-0H
	1500	8083793	ELGR-TB-55-1500-0H

Ordering data – Modular product system

Orientation guide

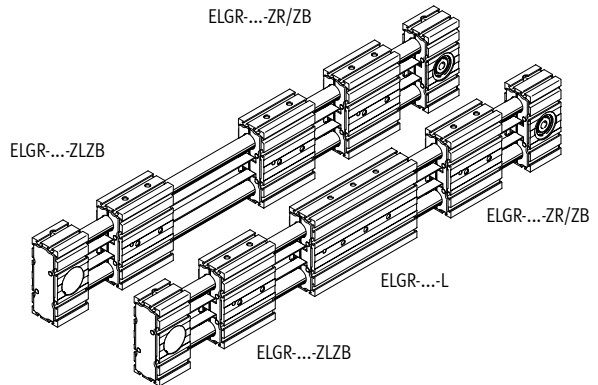
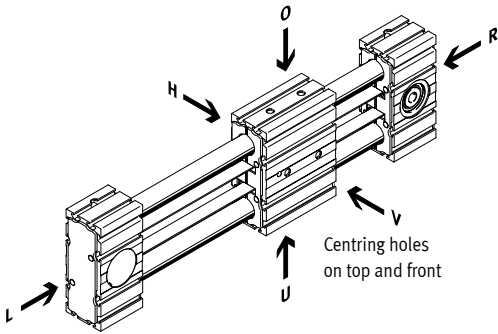

- O top
- U underneath
- R right
- L left
- V front
- H rear

Minimum order stroke in combination with additional slide ELGR...-ZR/ZL/ZB

Size	35		45		55	
ELGR...	-ZR/ZL	-ZB	-ZR/ZL	-ZB	-ZR/ZL	-ZB
Min. nominal stroke	[mm] 126	202	146	242	166	282

Accessories

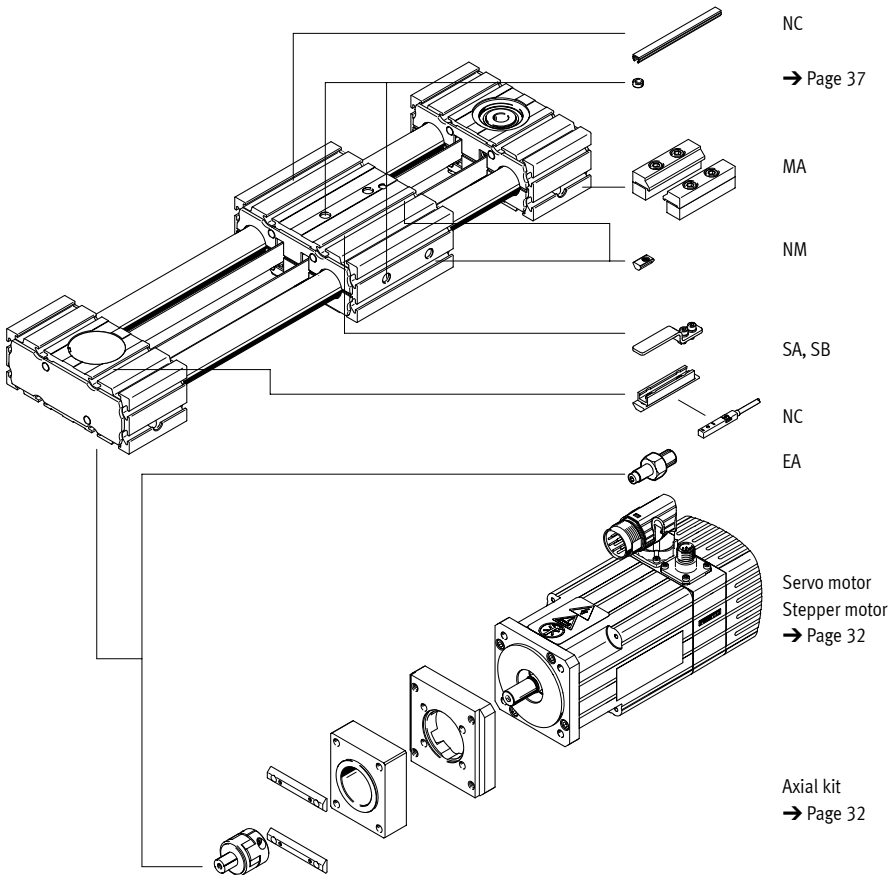

Ordering data – Modular product system

Ordering table	35	45	55	Conditions	Code	Enter code
Module no.	560505	560506	560507			
Design	Linear axis				ELGR	ELGR
Drive system	Toothed belt				-TB	-TB
Guide	Recirculating ball bearing guide					
	Plain-bearing guide				-GF	
Sizes	35	45	55		-...	
Stroke length [mm]	1 ... 800	1 ... 1000	1 ... 1500	[1]	-...	
Stroke reserve [mm]	0 ... 999 (0 = no stroke reserve)			[1]	-...H	
Slide design	Standard slide					
	Long slide				-L	
Additional slide	No additional slide					
	1 slide right			[2]	-ZR	
	1 slide left			[2]	-ZL	
	1 slide right, 1 slide left			[2]	-ZB	
Accessories	Accessories enclosed separately				+	+
Proximity sensor (SIES), inductive, slot type 8, PNP, N/O contact, cable 7.5 m, incl. switch lug and sensor bracket	1 ... 6				...SA	
Proximity sensor (SIES), inductive, slot type 8, PNP, N/C contact, cable 7.5 m, incl. switch lug and sensor bracket	1 ... 6				...SB	
Mounting slot cover	–	1 ... 50 (1=2 pcs. 500 mm long)			...NC	
Slot nut for mounting slot	1 ... 99				...NM	
Drive shaft	1 ... 4				...EA	
Profile mounting	1 ... 2				...MA	
Operating instructions	With operating instructions					
	Without operating instructions				+DN	

[1] ... The sum of the stroke length and 2x the stroke reserve must not exceed the maximum stroke length or be less than the minimum stroke length of 50 mm

[2] ZR, ZL, ZB Working stroke reduction → page 13

Peripherals overview

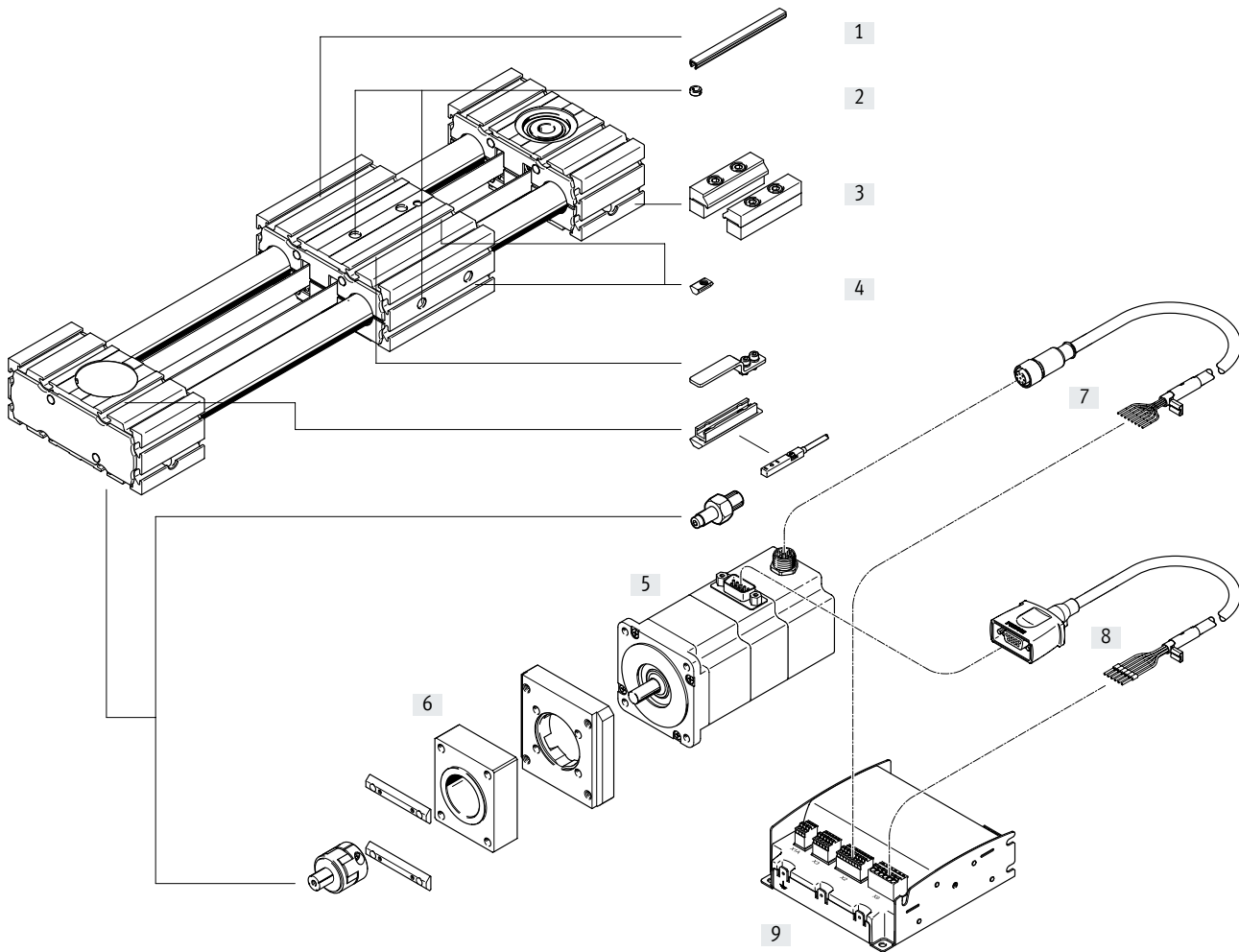



Peripherals overview

Accessories			
	Type/order code	Description	→ Page/Internet
[1]	Slot cover NC	• For protecting against contamination	37
[2]	Centring sleeve ZBH	• For centring loads and attachments on the slide • 2 centring sleeves included in the scope of delivery of the axis	37
[3]	Profile mounting MA	For mounting the axis on the bearing cap	36
[4]	Slot nut NM	For mounting attachments	37
[5]	Motor EMMS-ST	Motors specially matched to the axis, with or without brake	32
[6]	Axial kit EAMM	For axial motor mounting (comprises: coupling, coupling housing and motor flange)	32
[7]	Encoder cable NEBM	For connecting encoder and controller	38
[8]	Motor cable NEBM	For connecting motor and controller	38
[9]	Motor controller CMMO	For parameterising and positioning the toothed belt axis	38

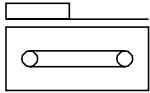
Data sheet



-  Size
35 ... 55
-  Stroke length
50 ... 1500 mm
-  www.festo.com

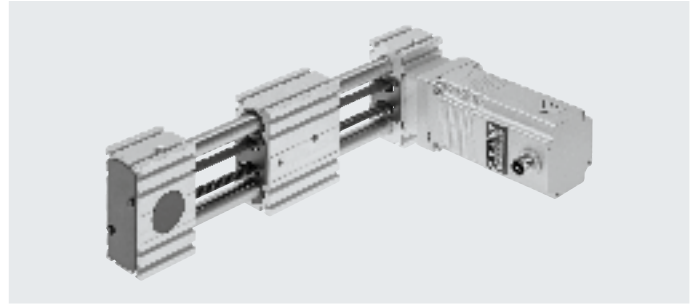

General technical data		35	45	55
Size		35	45	55
Design		Electromechanical linear axis with toothed belt		
Guide		Recirculating ball bearing guide		
Mounting position		Any		
Standard stroke	[mm]	50, 100, 150, 200, 250, 300, 350, 400, 450, 500, 550, 600, 650, 700, 750, 800	50, 100, 150, 200, 250, 300, 350, 400, 450, 500, 550, 600, 650, 700, 750, 800, 900, 1000	50, 100, 150, 200, 250, 300, 350, 400, 450, 500, 550, 600, 650, 700, 750, 800, 900, 1000, 1100, 1200, 1300, 1400, 1500
Max. payload	[kg]	2.8	5.0	6.8
Max. feed force F_x	[N]	50	100	350
Max. driving torque	[Nm]	0.46	1.24	5
Max. speed	[m/s]	1.1	1.1	0.35
Max. acceleration ¹⁾	[m/s ²]	15		
Repetition accuracy	[mm]	±0.1		

1) In combination with Optimised Motion Series (OMS).
The max. acceleration is dependent on the payload, the driving torque and the max. feed force → page 23

Operating and environmental conditions		
Ambient temperature	[°C]	-10 ... +50
Degree of protection		IP20
Duty cycle	[%]	100

Data sheet

Weight of axis/axial kit/motor [kg]			
Size	35	45	55
Basic weight with 0 mm stroke ¹⁾			
Axis/axial kit/motor	3.9	8.0	13.2
Additional weight per 1000 mm stroke	2.5	5.0	7.8
Moving mass	0.5	1.1	1.9
Slide			
Standard slide	0.5	1.0	1.8

1) Incl. slide

Materials

Sectional view

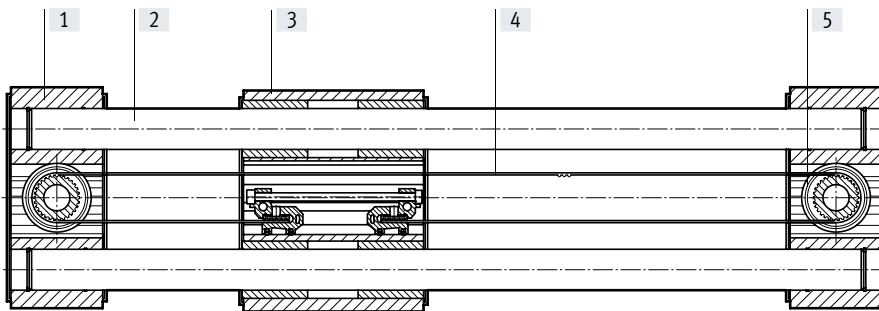

Axis		
[1]	Bearing cap, profile	Anodised wrought aluminium alloy
[2]	Guide rods	Hardened and hard-chromium plated tempered steel
[3]	Slide, profile	Anodised wrought aluminium alloy
[4]	Toothed belt	Polychloroprene with glass cord and nylon coating
[5]	Belt pulley	High-alloy stainless steel
	Note on materials	RoHS-compliant
		Contains paint-wetting impairment substances

Data sheet

Characteristic load values

The indicated forces and torques refer to the centre of the guide. The point of application of force is the point where the centre of the guide and the longitudinal centre of the slide intersect. These values must not be exceeded during dynamic operation. Special attention must be paid to the deceleration phase.

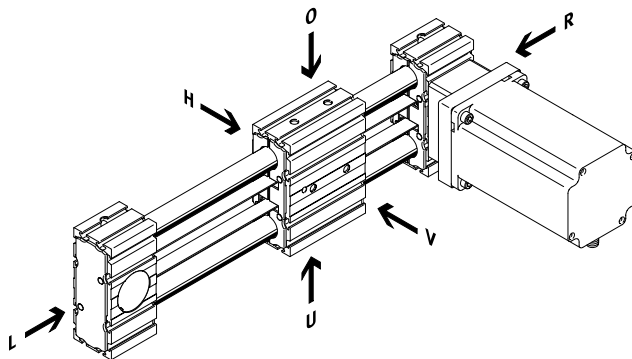

If the axis is subjected to several of the indicated forces and torques simultaneously, the following equation must be satisfied in addition to the indicated maximum loads:

Calculating the load comparison factor:

$$f_v = \frac{|F_{y1}|}{F_{y2}} + \frac{|F_{z1}|}{F_{z2}} + \frac{|M_{x1}|}{M_{x2}} + \frac{|M_{y1}|}{M_{y2}} + \frac{|M_{z1}|}{M_{z2}} \leq 1$$

F_1/M_1 = dynamic value

F_2/M_2 = maximum value

Permissible forces and torques for a service life of 5000 km

Guide Size	Recirculating ball bearing guide		
	35	45	55
$F_{y_{max}}, F_{z_{max}}^{1)}$ [N]	50	100	300
Standard slide			
$M_{x_{max}}$ [Nm]	2.5	5	15
$M_{y_{max}}$ [Nm]	8	16	48
$M_{z_{max}}$ [Nm]	8	16	48

1) Max. payload restricted by drive system in combination with Optimised Motion Series (OMS)

Service life

The service life of the guide depends on the load. To provide a rough indication of the service life of the guide, the graph below plots the load comparison factor f_v against the service life.

These values are only theoretical. You must consult your local contact person at Festo for load comparison factors f_v greater than 1.5.

Load comparison factor f_v as a function of service life

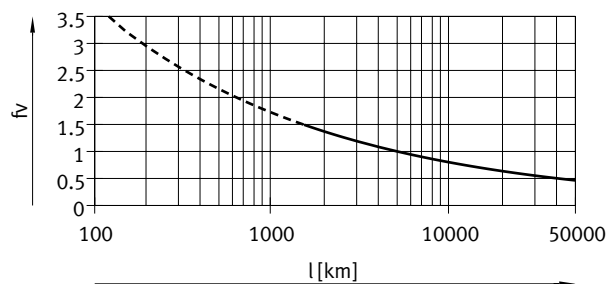

Example:

A user wants to move an X kg load. Using the above formula gives a value of 1.5 for the load comparison factor f_v . According to the graph, the guide would have a service life of approx. 1500 km. Reducing the acceleration reduces the M_z and M_y values. A load comparison factor of 1 now gives a service life of 5000 km.

Data sheet

Feed force F_x as a function of input torque M

ELGR-35

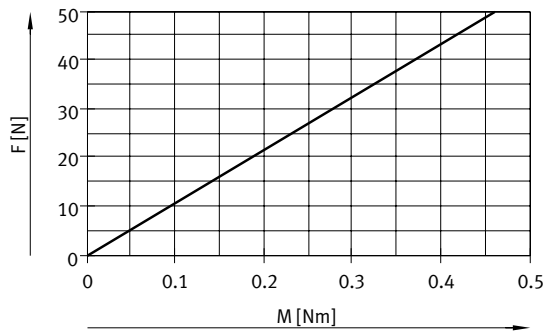

ELGR-45

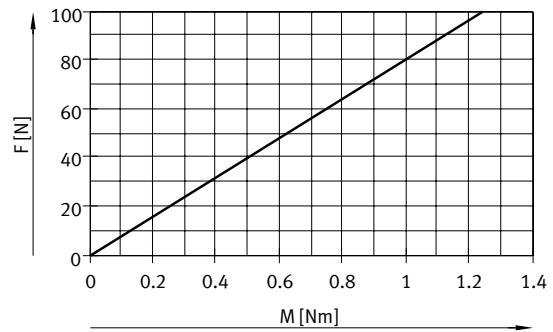

ELGR-55

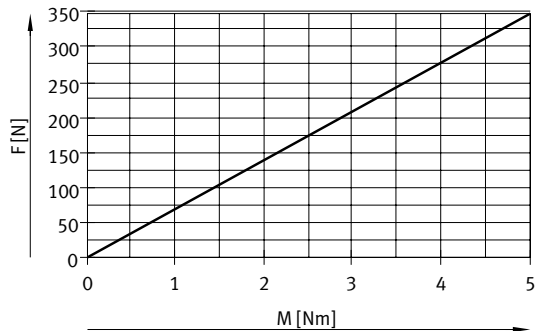

Max. payload m as a function of acceleration a and speed v^1

ELGR-35

ELGR-35 (OMS)

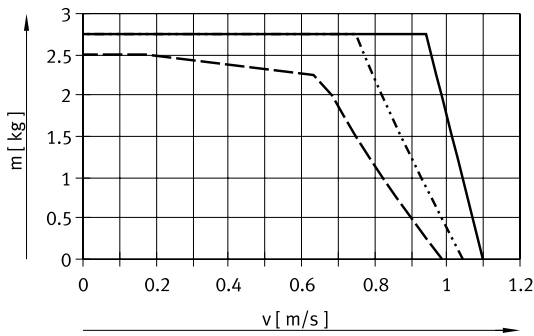

ELGR-45

ELGR-45 (OMS)

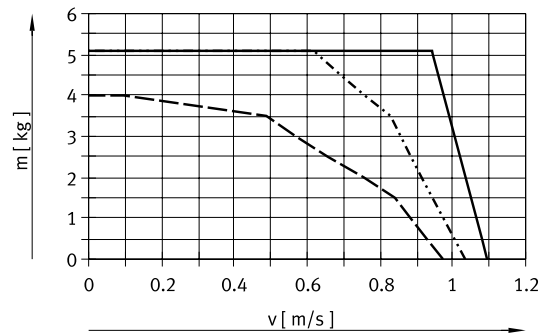

ELGR-55

ELGR-55 (OMS)

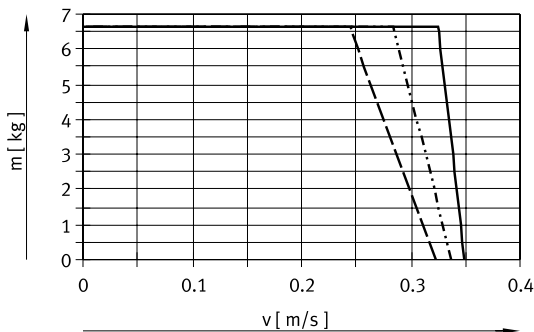

- 5 m/s²
- · - · 10 m/s²
- - - 15 m/s²

1) In combination with Optimised Motion Series (OMS)

Data sheet

Max. payload m as a function of stroke l and positioning time $t^1)$

ELGR-35

ELGR-45

ELGR-35 (OMS)

ELGR-45 (OMS)

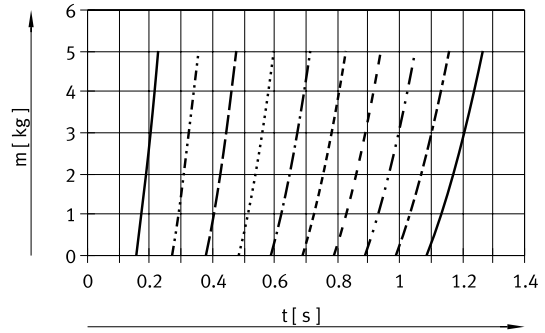
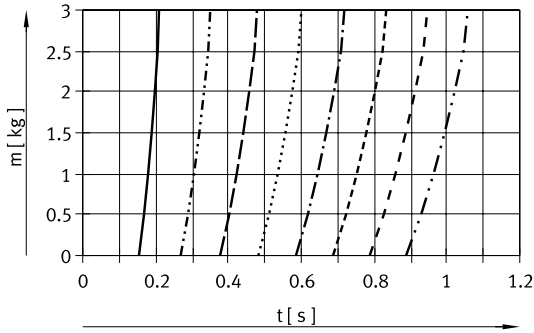

ELGR-55

ELGR-55 (OMS)

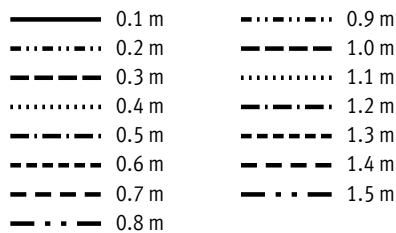
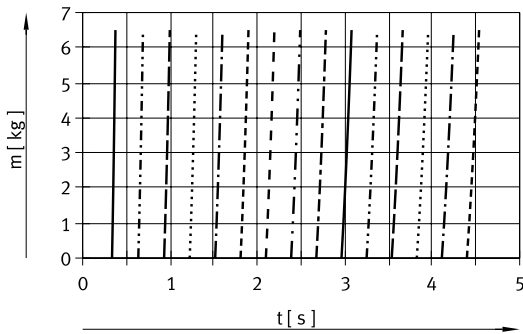

Max. load with flat mounting position¹⁾

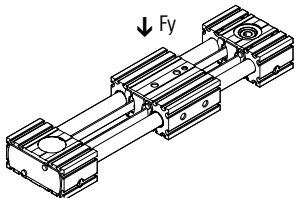

The characteristic curves in the graph correspond to the max. recommended deflection of 0.5 mm. In this case, the axis can no longer support the maximum load past a certain stroke length.

ELGR-TB-35/45/55 OMS

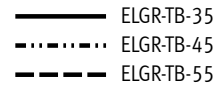
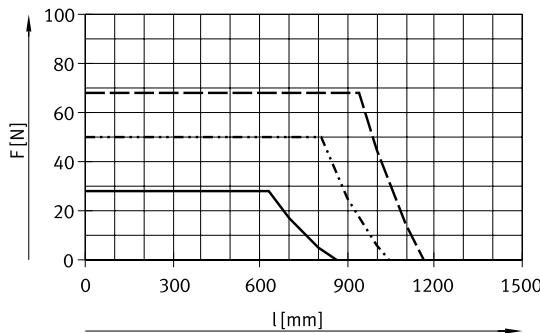

1) Max. payload restricted by drive system in combination with Optimised Motion Series (OMS)

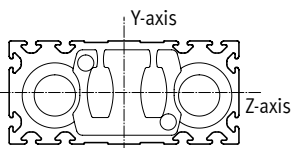

Second moment of area

Size		35	45	55
I_y	[mm ⁴]	4.19×10^3	17.95×10^3	41.18×10^3
I_z	[mm ⁴]	3.77×10^3	15.71×10^3	38.35×10^3

Recommended deflection limits

Adherence to a maximum deflection of 0.5 mm is recommended so as not to impair the functional performance of the axes. Greater deformation can result in increased friction, greater wear and reduced service life.

Data sheet

Dimensions

Download CAD data → www.festo.com

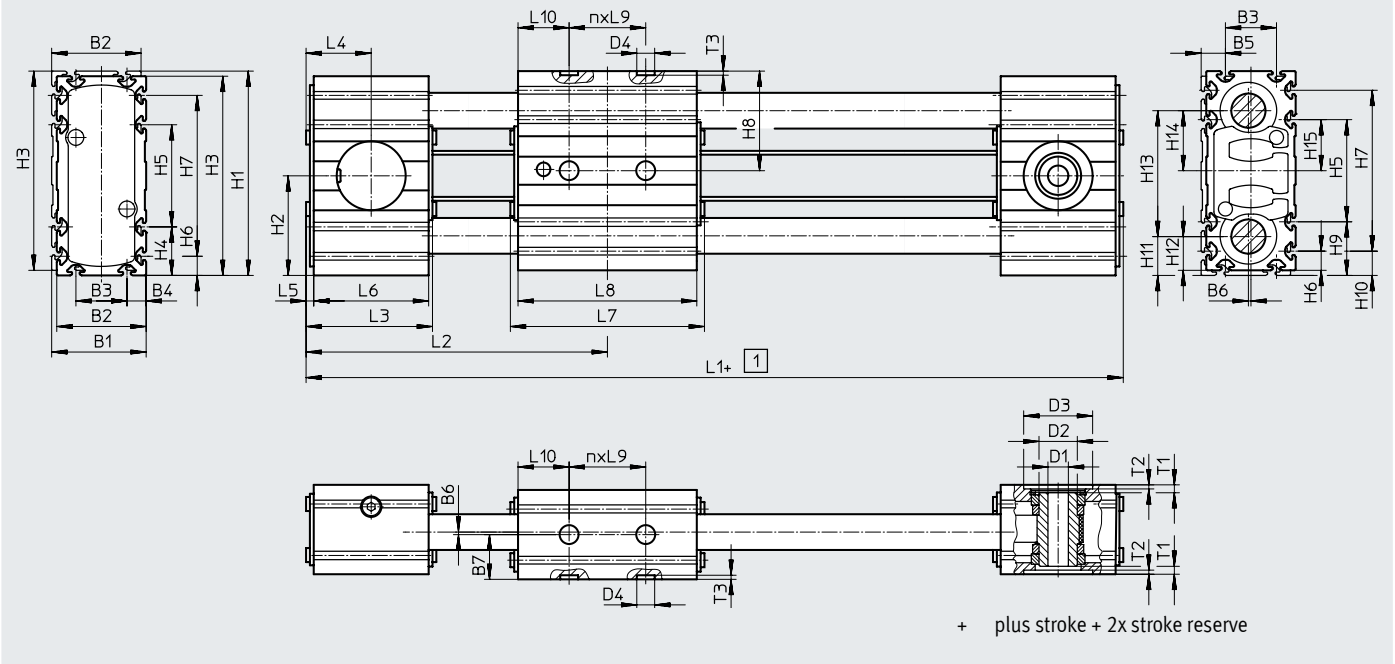

Size	B1	B2	B3	B4	B5	B6	B7	D1 ∅ H7	D2 ∅	D3 ∅ H7
35	37	35	20	7.5	9.5	1	17.5	8	15	27
45	47	45	20	12.5	14.5		22.5	10	20	38
55	57	55	30	12.5	14.5		27.5	16	25	48

Size	D4 ∅ H7	H1	H2	H3	H4	H5	H6	H7	H8	H9
35	7	80	39	78	19	40	7.5	63	39	21
45		117	57.5	115	32.5	50	12.5	90	57.5	34.5
55		137	67.5	135	32.5	70	12.5	110	67.5	34.5

Size	H10	H11	H12	H13	H14	H15	L1	L2	L3	L4
35	9.5	15.5	13.5	49	23.5	20	178	89	51	25.5
45	14.5	23	21	71	34.5	25	219	108	60	30
55	14.5	25.5	23.5	86	42	35	243	120	62	31

Size	L5	L6	L7	L8	L9	L10	T1	T2	T3	n
									+0.1	
35	3	45	76	70	30	20	3.1	1.6	1.6	1
45		54	96	90	40	25	3	1.7		1
55		56	116	110	40	35	4.5	2		1

Data sheet

Dimensions

Download CAD data → www.festo.com

Profile

ELGR-35

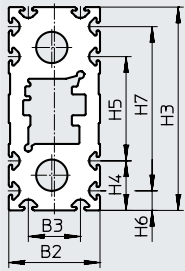

ELGR-45

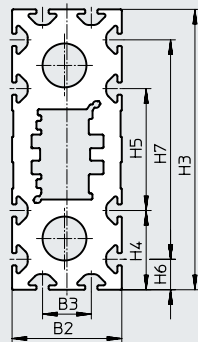

ELGR-55

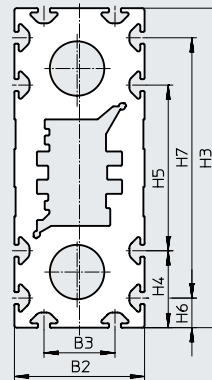

Size	B2	B3	H3	H4
35	35	20	78	19
45	45	20	115	32.5
55	55	30	135	32.5

Size	H5	H6	H7
35	40	7.5	63
45	50	12.5	90
55	70	12.5	110

Data sheet

Dimensions

Download CAD data → www.festo.com

Motor attachment variants

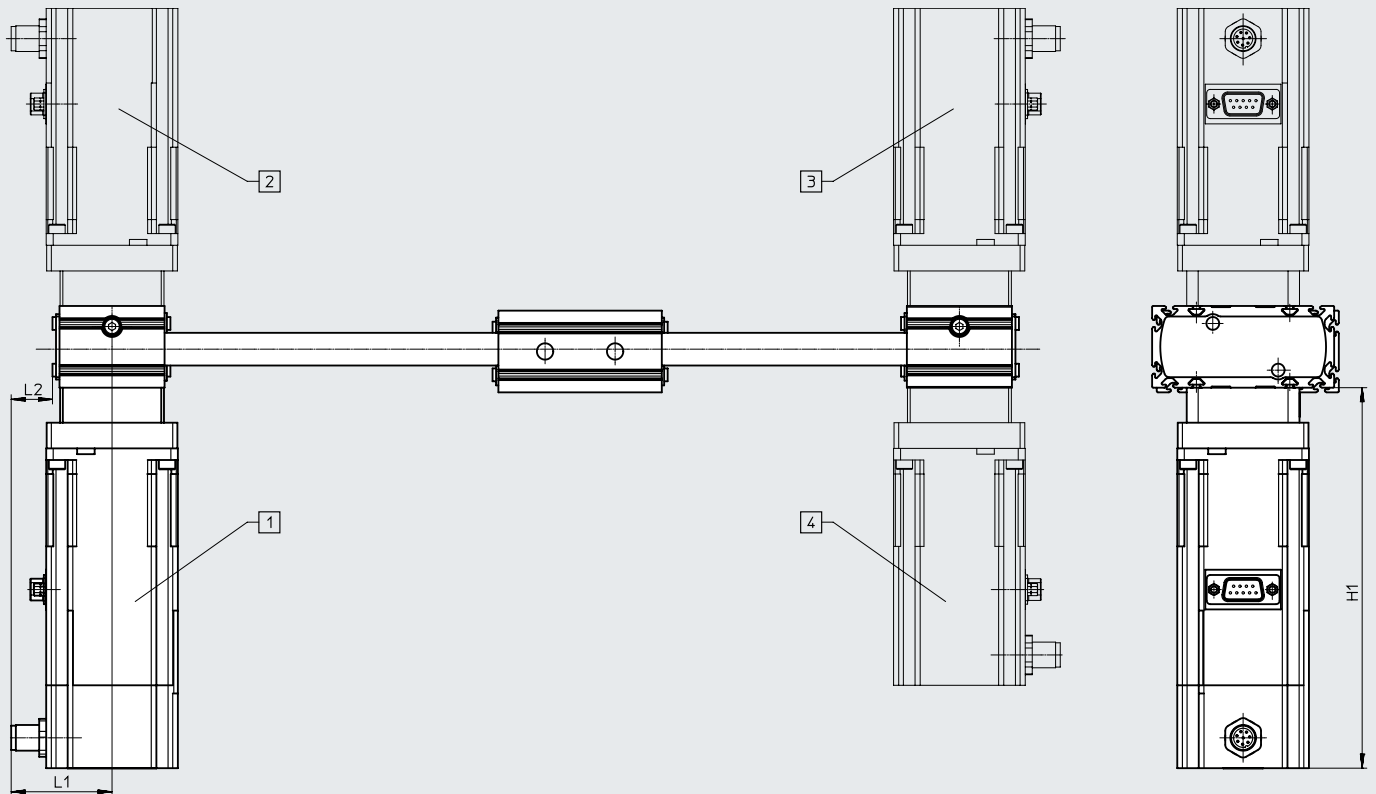

- [1] ELGR...-FL (motor at front left)
 [2] ELGR...-RL (motor at rear left)
 [3] ELGR...-RR (motor at rear right)
 [4] ELGR...-FR (motor at front right)

Size	H1		L1		L2	
	ELGR...	-B	ELGR...	-B	ELGR...	-B
35	127.5	163	43.2	44	17.7	18
45	152.4	192.5	58	58	28	28
55	190	230	58	58	27	27

Ordering data – Modular product system

Orientation guide

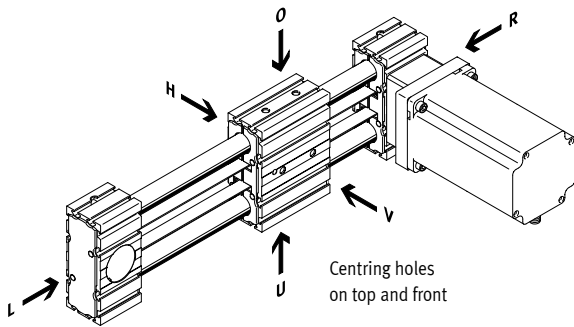

O top
U underneath
R right

L left
V front
H rear

Motor attachment variants

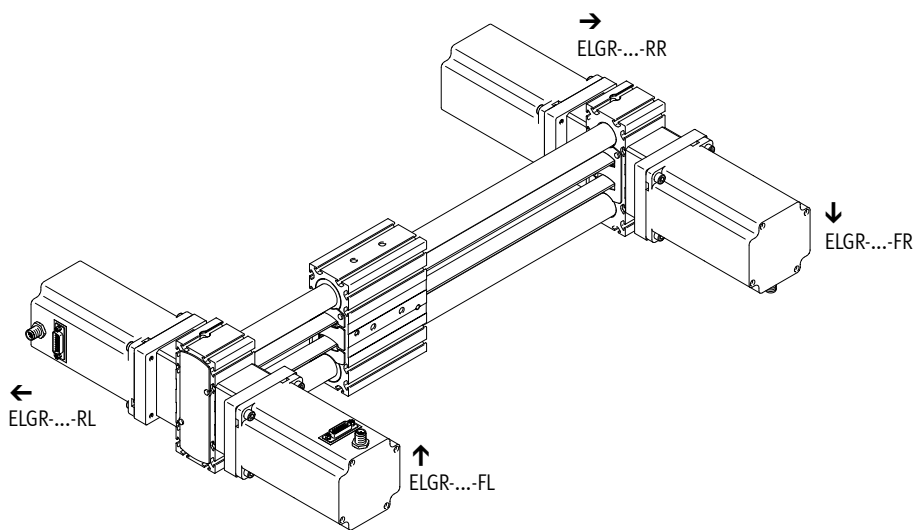

ELGR...-AR – right

ELGR...-AT – top

ELGR...-AL – left

ELGR...-AD – underneath

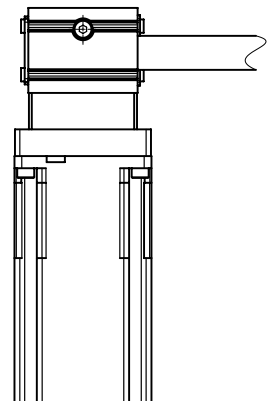
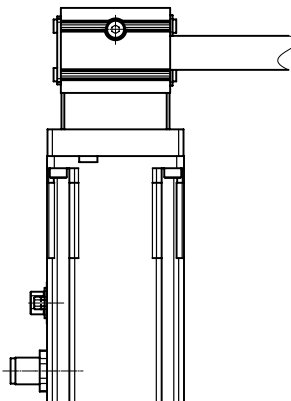
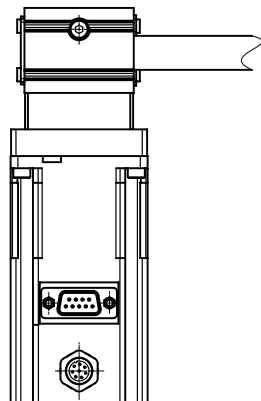
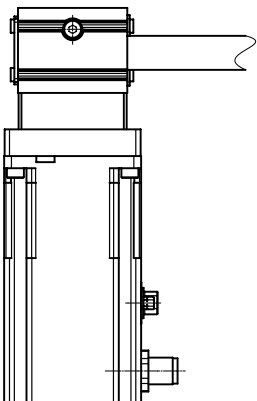
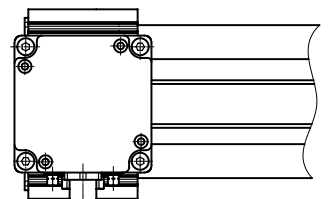
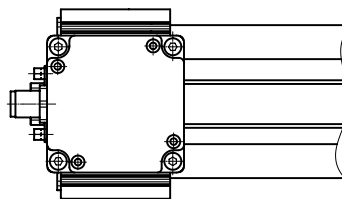
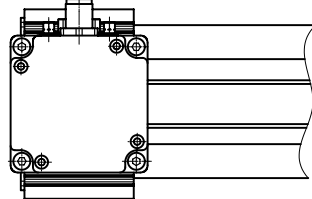
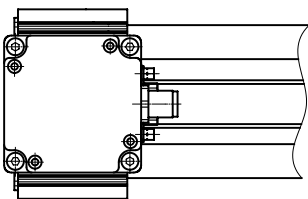

Ordering data – Modular product system

Accessories

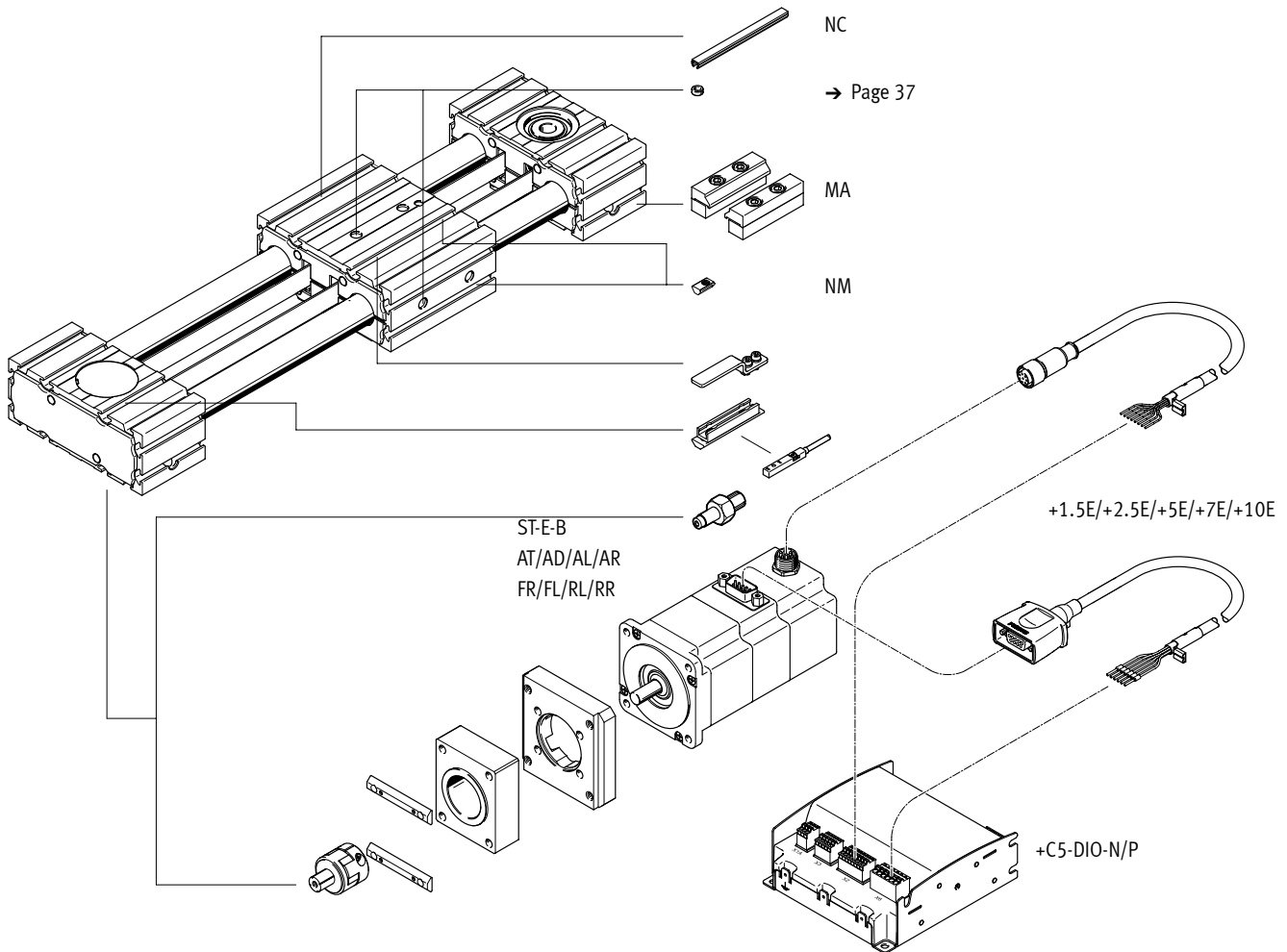

 **Note**

The associated axial kit (→ Page 32) is automatically included in the scope of delivery.
Motor and axial kits are installed on delivery.

Toothed belt axes ELGR, for Optimised Motion Series (OMS)

Ordering data – Modular product system

	35	45	55	Conditions	Code	Enter code
Module no.	560505	560506	560507			
Design	Linear axis				ELGR	ELGR
Drive system	Toothed belt				-TB	-TB
Sizes	35	45	55		-...	
Standard stroke [mm]	50, 100, 150, 200, 250, 300, 350, 400, 450, 500, 550, 600, 650, 700, 750, 800	50, 100, 150, 200, 250, 300, 350, 400, 450, 500, 550, 600, 650, 700, 750, 800, 900, 1000	50, 100, 150, 200, 250, 300, 350, 400, 450, 500, 550, 600, 650, 700, 750, 800, 900, 1000, 1100, 1200, 1300, 1400, 1500			
Stroke reserve [mm]	0 mm				-OH	-OH
Slide design	Standard slide					
Motor type	Stepper motor				-ST	-ST
Measuring unit	Encoder				-E	-E
Brake	None					
	With brake				B	
Cable outlet direction	Top (standard)				-AT	
	Underneath				-AD	
	Left				-AL	
	Right				-AR	
Motor position	Front right (standard)				-FR	
	Front left				-FL	
	Rear left				-RL	
	Rear right				-RR	

Ordering data – Modular product system

	35	45	55	Conditions	Code	Enter code
Accessories	Accessories enclosed separately				+	+
Mounting slot cover	-	1 ... 50 (1=2 pcs. 500 mm long)			...NC	
Slot nut for mounting slot	1 ... 99				...NM	
Profile mounting	1 ... 2				...MA	
Connecting cable to motor controller, suitable for use with energy chains	None					
	1.5 m, straight plug				+1.5E	
	2.5 m, straight plug				+2.5E	
	5 m, straight plug				+5E	
	7 m, straight plug				+7E	
	10 m, straight plug				+10E	
Controller type	CMMO, 5 A				+C5	+C5
Bus protocol/control	Digital I/O interface				DIO	
	IO-Link				LK	
Switching input/output	NPN			[1]	N	
	PNP				P	
Operating instructions	With operating instructions					
	Without operating instructions				+DN	

[1] N Not with LK

Accessories

-  - Note

Depending on the combination of motor and drive, it may not be possible to reach the maximum feed force of the drive.

Permissible axis/motor combinations with axial kit

Data sheets → Internet: eamm-a

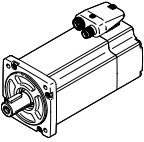
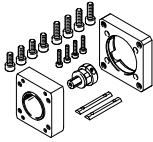
Motor/gear unit ¹⁾	Axial kit	
Type	Part no.	Type
		
ELGR-35		
With servo motor		
EMMS-AS-55-...	1133400	EAMM-A-R27-55A
With servo motor and gear unit		
EMME-AS-40-... EMGA-40-P-G...-EAS-40	1456622	EAMM-A-R27-40G
EMMS-AS-40-... EMGA-40-P-G...-SAS-40	1456622	EAMM-A-R27-40G
With servo motor and angled gear unit		
EMME-AS-40-... EMGA-40-A-G...-40P	1456622	EAMM-A-R27-40G
With stepper motor		
EMMS-ST-57-... ²⁾	1133403	EAMM-A-R27-57A
With stepper motor and gear unit		
EMMS-ST-42-... EMGA-40-P-G...-SST-42	1456622	EAMM-A-R27-40G
With integrated drive		
EMCA-EC-67-...	1456619	EAMM-A-R27-67A
With integrated drive and gear unit		
EMCA-EC-67-... EMGC-40-...	1456622	EAMM-A-R27-40G

1) The input torque must not exceed the maximum permissible transferable torque of the axial kit

2) Motors used in combination with Optimised Motion Series (OMS)

Accessories

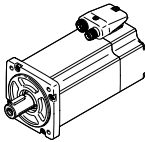
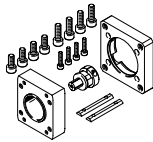
Permissible axis/motor combinations with axial kit		Data sheets → Internet: eamm-a	
Motor/gear unit ¹⁾	Axial kit		
			
Type	Part no.	Type	
ELGR-45			
EMMT-AS-60-...	2224996	EAMM-A-R38-60P	
EMME-AS-60-...	2224996	EAMM-A-R38-60P	
EMMS-AS-70-...	1133401	EAMM-A-R38-70A	
With servo motor and gear unit			
EMME-AS-40-...	1456623	EAMM-A-R38-40G	
EMGA-40-P-G...-EAS-40			
EMMS-AS-40-...	1456623	EAMM-A-R38-40G	
EMGA-40-P-G...-SAS-40			
EMMS-AS-55-...	2310075	EAMM-A-R38-60G	
EMGA-60-P-G...-SAS-55			
EMMT-AS-60-...	1456630	EAMM-A-R38-60H	
EMGA-60-P-G...-EAS-60			
EMME-AS-60-...	1456630	EAMM-A-R38-60H	
EMGA-60-P-G...-EAS-60			
EMMS-AS-70-...	2310075	EAMM-A-R38-60G	
EMGA-60-P-G...-SAS-70			
With servo motor and angled gear unit			
EMME-AS-40-...	1456623	EAMM-A-R38-40G	
EMGA-40-A-G...-40P			
EMMT-AS-60-...	1456630	EAMM-A-R38-60H	
EMGA-60-A-G...-60P			
EMME-AS-60-...	1456630	EAMM-A-R38-60H	
EMGA-60-A-G...-60P			
With stepper motor			
EMMS-ST-57-...	1578138	EAMM-A-R38-57A	
EMMS-ST-87-... ²⁾	1133404	EAMM-A-R38-87A	
With stepper motor and gear unit			
EMMS-ST-42-...	1456623	EAMM-A-R38-40G	
EMGA-40-P-G...-SST-42			
EMMS-ST-57-...	2310075	EAMM-A-R38-60G	
EMGA-60-P-G...-SST-57			
With integrated drive and gear unit			
EMCA-EC-67-...	1456623	EAMM-A-R38-40G	
EMGC-40-...			
EMCA-EC-67-...	1456630	EAMM-A-R38-60H	
EMGC-60-...			

1) The input torque must not exceed the maximum permissible transferable torque of the axial kit

2) Motors used in combination with Optimised Motion Series (OMS)

Accessories

Data sheets → Internet: eamm-a

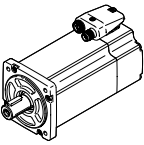
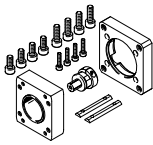
Permissible axis/motor combinations with axial kit		
Motor/gear unit ¹⁾	Axial kit	
		
Type	Part no.	Type
ELGR-55		
With servo motor		
EMMS-AS-70-...	1578139	EAMM-A-R48-70A
EMME-AS-80-...	2225090	EAMM-A-R48-80P
EMMS-AS-100-...	1133402	EAMM-A-R48-100A
With servo motor and gear unit		
EMMS-AS-55-...	2374780	EAMM-A-R48-60G
EMGA-60-P-G...-SAS-55		
EMMT-AS-60-...	1456633	EAMM-A-R48-60H
EMGA-60-P-G...-EAS-60		
EMME-AS-60-...	1456633	EAMM-A-R48-60H
EMGA-60-P-G...-EAS-60		
EMMS-AS-70-...	2374780	EAMM-A-R48-60G
EMGA-60-P-G...-SAS-70		
With servo motor and angled gear unit		
EMMT-AS-60-...	1456633	EAMM-A-R48-60H
EMGA-60-A-G...-60P		
EMME-AS-60-...	1456633	EAMM-A-R48-60H
EMGA-60-A-G...-60P		
With stepper motor		
EMMS-ST-87-... ²⁾	1133405	EAMM-A-R48-87A
With stepper motor and gear unit		
EMMS-ST-57-...	2374780	EAMM-A-R48-60G
EMGA-60-P-G...-SST-57		
With integrated drive and gear unit		
EMCA-EC-67-...	1456633	EAMM-A-R48-60H
EMGC-60-...		

1) The input torque must not exceed the maximum permissible transferable torque of the axial kit

2) Motors used in combination with Optimised Motion Series (OMS)

Accessories

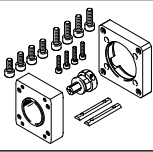
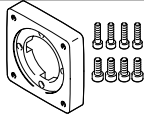
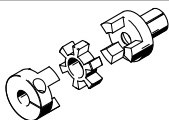
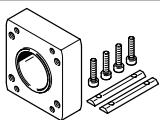
Permissible axis/motor combinations with axial kit			
Axial kit	Comprising: Motor flange	Coupling	Coupling housing
			
Part no. Type	Part no. Type	Part no. Type	Part no. Type
ELGR-35			
1456622 EAMM-A-R27-40G	1460097 EAMF-A-38A-40G	557998 EAMD-19-15-10-8X10	1133397 EAMK-A-R27-38A
1133400 EAMM-A-R27-55A	558176 EAMF-A-38A-55A	557999 EAMD-19-15-9-8X10	1133397 EAMK-A-R27-38A
1133403 EAMM-A-R27-57A	560692 EAMF-A-38A-57A	561292 EAMD-16-15-6.35-8X10	1133397 EAMK-A-R27-38A
1456619 EAMM-A-R27-67A	1490100 EAMF-A-38A-67A	557999 EAMD-19-15-9-8X10	1133397 EAMK-A-R27-38A
ELGR-45			
1456623 EAMM-A-R38-40G	1460097 EAMF-A-38A-40G	1453860 EAMD-25-22-10-10X12	1133398 EAMK-A-R38-38A
1578138 EAMM-A-R38-57A	560692 EAMF-A-38A-57A	561293 EAMD-25-22-6.35-10X12	1133398 EAMK-A-R38-38A
2310075 EAMM-A-R38-60G	558017 EAMF-A-38A-60G/H	558000 EAMD-25-22-11-10X12	1133398 EAMK-A-R38-38A
1456630 EAMM-A-R38-60H	558017 EAMF-A-38A-60G/H	1453861 EAMD-28-22-14-10X12	1133398 EAMK-A-R38-38A
2224996 EAMM-A-R38-60P	1987412 EAMF-A-38A-60P	1453861 EAMD-28-22-14-10X12	1133398 EAMK-A-R38-38A
1133401 EAMM-A-R38-70A	558018 EAMF-A-38A-70A	558000 EAMD-25-22-11-10X12	1133398 EAMK-A-R38-38A
1133404 EAMM-A-R38-87A	560693 EAMF-A-38A-87A	558000 EAMD-25-22-11-10X12	1133398 EAMK-A-R38-38A
ELGR-55			
2374780 EAMM-A-R48-60G	558019 EAMF-A-48A-60G/H	558001 EAMD-32-32-11-16X20	1133399 EAMK-A-R48-48A
1456633 EAMM-A-R48-60H	558019 EAMF-A-48A-60G/H	1377840 EAMD-32-32-14-16X20	1133399 EAMK-A-R48-48A
1578139 EAMM-A-R48-70A	558025 EAMF-A-48A-70A	558001 EAMD-32-32-11-16X20	1133399 EAMK-A-R48-48A
2225090 EAMM-A-R48-80P	2043427 EAMF-A-48A-80P	558002 EAMD-42-40-19-16X25	1133399 EAMK-A-R48-48A
1133405 EAMM-A-R48-87A	560695 EAMF-A-48A-87A	558001 EAMD-32-32-11-16X20	1133399 EAMK-A-R48-48A
1133402 EAMM-A-R48-100A	558020 EAMF-A-48A-100A	558002 EAMD-42-40-19-16X25	1133399 EAMK-A-R48-48A

Accessories

Profile mounting MUE (order code MA)

Material:
Anodised aluminium
RoHS-compliant

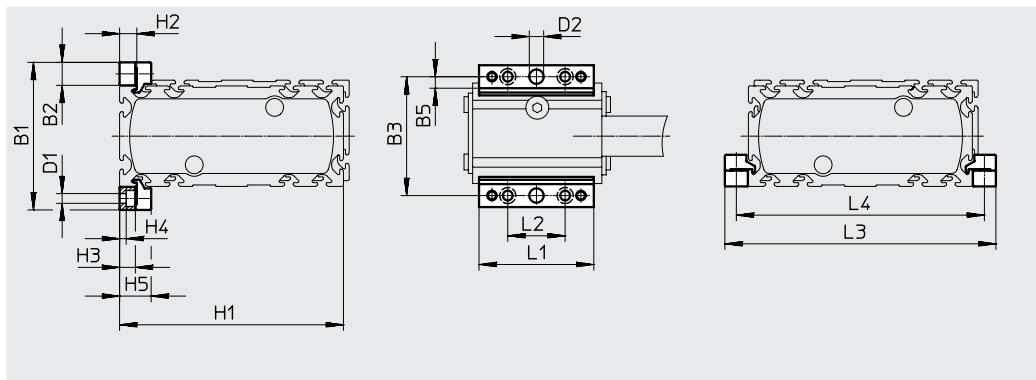

Dimensions and ordering data											
For size	B1	B2	B3	B5	D1 ∅	D2 ∅ H7	H1	H2	H3	H4	
35	51	8	43	4	3.4	5	78	6	5.5	2.3	
45	69	12	57	4	5.5	5	115	10	9	3.2	
55	79	12	67	4	5.5	5	135	10	9	3.2	

For size	H5	L1	L2	L3	L4	Weight [g]	Part no.	Type
35	11	40	20	94	86	20	558042	MUE-50
45	17.5	52	40	139	127	32	562238	MUE-45
55	17.5	52	40	159	147	32	562238	MUE-45

Sensor bracket EAPM-...-SHS, Switch lug EAPM-...-SLS (order code SA/SB)

Material:
Switch lug: Galvanised steel
Sensor bracket: Anodised wrought
aluminium alloy
RoHS-compliant

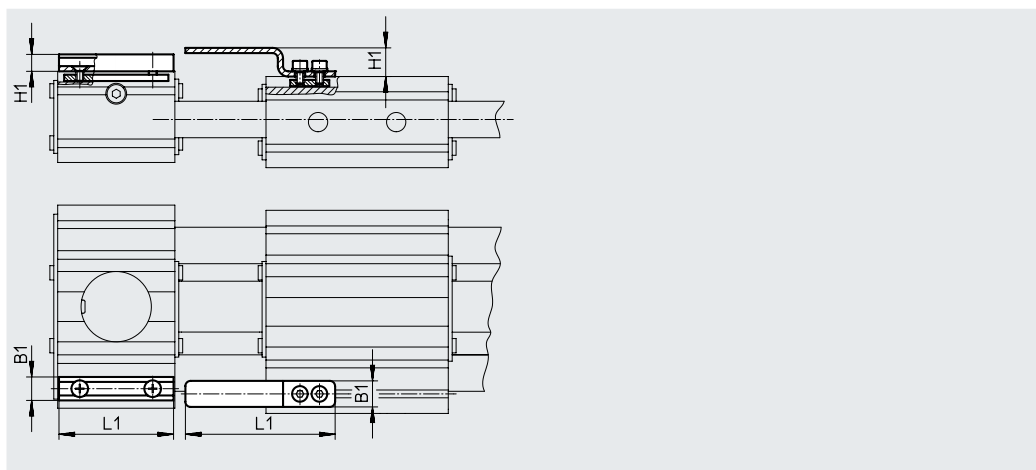

Dimensions and ordering data							
For size	B1	H1	L1	Weight [g]	Part no.	Type	
Sensor bracket							
35, 45, 55	9	6.5	44	20	567537	EAPM-L4-SHS	
Switch lug							
35, 45, 55	10	11	57.5	15	567538	EAPM-L4-SLS	

Accessories

Drive shaft EAMB
Alternative interface
(order code EA)

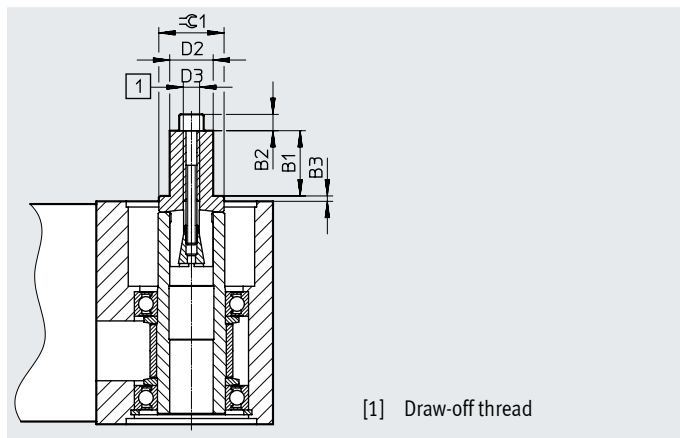
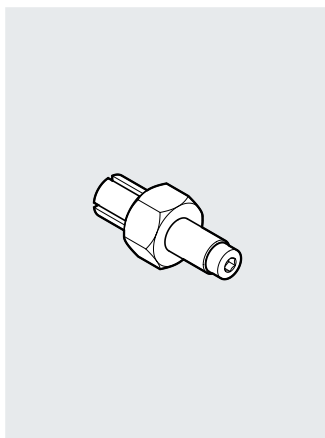

[1] Draw-off thread

Dimensions and ordering data

For size	B1	B2	B3	D2 ∅	D3	$\approx C1$	Weight [g]	Part no.	Type
35	12	3	3.9	8	M4	12	20	558034	EAMB-16-7-8X15-8X10
45	12	4	6	8	M5	15	29	558035	EAMB-18-9-8X16-10X12
55	21	–	1.5	15	M6	21	70	558036	EAMB-24-6-15X21-16X20

Ordering data



	For size	Comment	Order code	Part no.	Type	PE ¹⁾
Slot nut NST						
	35	For mounting slot	NM	558045	NST-3-M3	1
	45, 55			150914	NST-5-M5	
		–	8047843	NST-5-M5-10	10	
			8047878	NST-5-M5-50	50	
Centring sleeve ZBH²⁾						
	35, 45, 55	For slide	–	186717	ZBH-7	10
Slot cover ABP						
	45, 55	For mounting slot Every 0.5 m	NC	151681	ABP-5	2

1) Packaging unit

2) 2 centring sleeves included in the scope of delivery of the axis

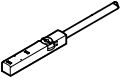
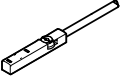
Accessories

Ordering data – Proximity sensors for T-slot, inductive							Data sheets → Internet: sies
	Type of mounting	Electrical connection	Switching output	Cable length [m]	Order code	Part no.	Type
N/O contact							
	Insertable in the slot from above, flush with the cylinder profile	Cable, 3-wire	PNP	7.5	SA	551386	SIES-8M-PS-24V-K-7,5-OE
		Plug M8x1, 3-pin		0.3	–	551387	SIES-8M-PS-24V-K-0,3-M8D
		Cable, 3-wire	NPN	7.5	–	551396	SIES-8M-NS-24V-K-7,5-OE
		Plug M8x1, 3-pin		0.3	–	551397	SIES-8M-NS-24V-K-0,3-M8D
N/C contact							
	Insertable in the slot from above, flush with the cylinder profile	Cable, 3-wire	PNP	7.5	SB	551391	SIES-8M-PO-24V-K-7,5-OE
		Plug M8x1, 3-pin		0.3	–	551392	SIES-8M-PO-24V-K-0,3-M8D
		Cable, 3-wire	NPN	7.5	–	551401	SIES-8M-NO-24V-K-7,5-OE
		Plug M8x1, 3-pin		0.3	–	551402	SIES-8M-NO-24V-K-0,3-M8D

Ordering data – Connecting cables						Data sheets → Internet: nebu
	Electrical connection, left	Electrical connection, right	Cable length [m]	Part no.	Type	
	Straight socket, M8x1, 3-pin	Cable, open end, 3-wire	2.5	541333	NEBU-M8G3-K-2.5-LE3	
			5.0	541334	NEBU-M8G3-K-5-LE3	
	Angled socket, M8x1, 3-pin	Cable, open end, 3-wire	2.5	541338	NEBU-M8W3-K-2.5-LE3	
			5.0	541341	NEBU-M8W3-K-5-LE3	

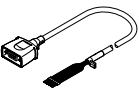
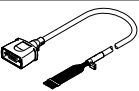
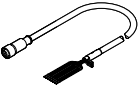
Ordering data – Cables ¹⁾					
	For size	Description	Cable length [m]	Part no.	Type
Motor cable					
	35	Straight plug • Min. bending radius: 62 mm • Suitable for energy chains • Ambient temperature: –40 ... +80°C	1.5	1450368	NEBM-S1G9-E-1.5-Q5-LE6
			2.5	1450369	NEBM-S1G9-E-2.5-Q5-LE6
			5.0	1450370	NEBM-S1G9-E-5-Q5-LE6
			7.0	1450371	NEBM-S1G9-E-7-Q5-LE6
			10.0	1450372	NEBM-S1G9-E-10-Q5-LE6
	45, 55	Straight plug • Min. bending radius: 80 mm • Suitable for energy chains • Ambient temperature: –40 ... +80°C	1.5	1450834	NEBM-S1G15-E-1.5-Q7-LE6
			2.5	1450835	NEBM-S1G15-E-2.5-Q7-LE6
			5.0	1450836	NEBM-S1G15-E-5-Q7-LE6
			7.0	1450837	NEBM-S1G15-E-7-Q7-LE6
			10.0	1450838	NEBM-S1G15-E-10-Q7-LE6
Encoder cable					
	35, 45, 55	Straight plug • Min. bending radius: 68 mm • Suitable for energy chains • Ambient temperature: –40 ... +80°C	1.5	1451586	NEBM-M12G8-E-1.5-LE8
			2.5	1451587	NEBM-M12G8-E-2.5-LE8
			5.0	1451588	NEBM-M12G8-E-5-LE8
			7.0	1451589	NEBM-M12G8-E-7-LE8
			10.0	1451590	NEBM-M12G8-E-10-LE8

1) Other cable lengths on request.

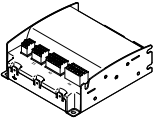
Ordering data – Motor controller				Data sheets → Internet: cmmo
	Description	Part no.	Type	
	With I/O interface			
	Switching input/output PNP	1512316	CMMO-ST-C5-1-DIOP	
	Switching input/output NPN	1512317	CMMO-ST-C5-1-DION	
	With IO-Link®			
Switching input/output PNP	1512320	CMMO-ST-C5-1-LKP		