

Variable displacement pump A7VO

RE 92 203/05.99 1/24
Replaces: 03.92

open circuit

Size 250...1000
 Series 6
 Nominal pressure 350 bar
 Peak pressure 400 bar

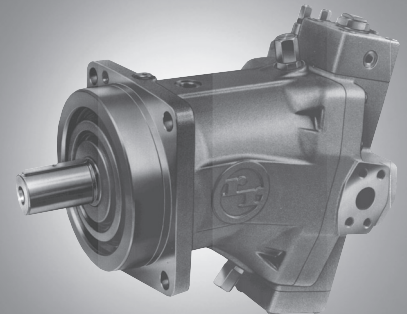

Contents

Ordering code / standard range / preferred range	2, 3
Technical data	4, 5, 6
Unit dimensions Size 250	7
Unit dimensions Size 355	8
Unit dimensions Size 500	9
Unit dimensions Size 1000	10
Power controller LRD	11
with integrated pressure control LRD	12
with remote-controlled pressure control LRG	13
with hydraulic stroke limitation V_{gmax} LRDH	14
with hydraulic stroke limitation V_{gmin} LRDN	15
Pressure controller DR	16
with remote-controlled pressure control DRG	17
Hydraulic control HDD	18
with pressure control HDD and HDG	19
Hydraulic control with electrical proportional valve EPD	20
with pressure control EPD and EPG	21
Visual and electrical swivel angle indication	22
Preferred types	23

Features

- Variable-displacement axial piston pump with bent axis for hydrostatic drives in open circuits
- Flow is proportional to drive speed and displacement. It can be infinitely varied by adjustment of the bent axis.
- Axial tapered piston rotary group of bent axis design
- Infinitely variable displacement
- Compact, robust bearing system designed for long service life
- Optional long-life bearings
- Good performance-to-weight ratio
- Low flywheel effect
- Large range of control devices
- Pressure control supplied as standard
- External controller adjustment during operation
- Optional visual or electrical swivel angle indication
- Can be installed in any position
- HF operation possible with reduced specifications
- Further information:
 Variable displacement pump A7VO RE 92 202
 Sizes 55 - 160

Ordering code

= Preferred range (short delivery times)
(Preferred types see page 23)

Fluid

Mineral oil (no short code)	
HF fluids (only with shaft bearing "L")	E

Axial piston unit

Bent axis design, variable	
Nominal pressure 350 bar, peak pressure 400 bar	A7V

Drive shaft bearings

	250	355	500	1000	
Mechanical bearings (no short code)	●	●	●	-	
Long-life bearings	●	●	●	●	L

Operating mode

Pump, open-loop circuit	0
-------------------------	----------

Size

Displacement V_g (cm ³)	55-160 see RE 92 202	250	355	500	1000
--	----------------------	------------	------------	------------	-------------

Control devices

Power controller	LR		D				●	●	●	○	LRD
	LR			G			●	●	●	○	LRG
	LR		D		H1		●	●	●	○	LRDH1
	LR			G	H1		●	●	●	○	LRGH1
	LR		D		H2		●	●	●	○	LRDH2
	LR			G	H2		●	●	●	○	LRGH2
	LR		D		H3		●	●	●	○	LRDH3
	LR			G	H3		●	●	●	○	LRGH3
	LR		D			N1	●	●	●	○	LRDN1
	LR			G		N1	●	●	●	○	LRGN1
	LR		D			N2	●	●	●	○	LRDN2
	LR			G		N2	●	●	●	○	LRGN2
	LR		D			N3	●	●	●	○	LRDN3
	LR			G		N3	●	●	●	○	LRGN3
Integrated pressure control (invariable)											
Remote-controlled pressure control											
Hydraulic stroke control, basic setting V_{gmin} 1 = Δp 10bar; 2 = Δp 25bar; 3 = Δp 35bar Hydraulic stroke limitation, basic setting V_{gmax}											
Pressure controller	DR						●	●	●	○	DR
	DR		G				●	●	●	○	DRG
Remote-controlled pressure control											
Hydraulic control, dependent on pilot pressure	HD	1	D				●	●	●	●	HD1D
	HD	1		G			●	●	●	●	HD1G
	HD	2	D				●	●	●	●	HD2D
	HD	2		G			●	●	●	●	HD2G
	HD	3	D				●	●	●	●	HD3D
	HD	3		G			●	●	●	●	HD3G
Pilot pressure increase $\Delta p = 10$ bar (1); 25 bar (2); 35 bar (3)											
										Remote-controlled pressure control	
										Integrated pressure control (invariable)	
Hydraulic control with electrical proportional valve	EP	1	D				●	●	●	○	EP1D
	EP	1		G			●	●	●	○	EP1G
	EP	2	D				●	●	●	○	EP2D
	EP	2		G			●	●	●	○	EP2G
Control voltage 12 V (1) Control voltage 24 V (2)											
										Remote-controlled pressure control	
										Integrated pressure control (invariable)	

Ordering code

A7V **O** / **63** - **V**

Fluid

Axial piston unit

Drive shaft bearings

Operating mode

Size

Control devices

Series

63

Direction of rotation

Viewed on shaft end

clockwise

R

anticlockwise

L

Seals

FKM (fluoride rubber to DIN ISO 1629)

V

Shaft ends

Splined shaft DIN 5480

Z

Parallel with key DIN 6885

P

Mounting flange

250 355 500 1000

ISO - 4 hole

●

-

-

-

B

ISO - 8 hole

-

●

●

●

H

Connection for service lines

250 355 500 1000

Pressure ports A(B)

Suction port S

} }

SAE at rear
(metric thread)

●

●

●

●

01

Pressure ports A(B)

Suction port S

} }

SAE on opposite sides
(metric thread)

●

●

●

○

02

Swivel angle indication

250 355 500 1000

Without swivel angle indication (no short code)

●

●

●

-

With visual swivel angle indication

●

●

●

●

V

With electrical swivel angle indication

●

●

●

●

E

- = available
- = in preparation
- = not available

Technical data

Hydraulic fluid

Before starting a project, please obtain detailed information on the choice of hydraulic fluids and application conditions from our catalogue data sheets RE 90220 (Mineral oil), RE 90221 (Environment-friendly hydraulic fluids) and RE 90223 (HF fluids).

Reduced operating data may have to be considered when using HF fluids and ecologically acceptable fluids. Please consult us. (when ordering, please print the full name of the hydraulic fluid used in your application)

Operating viscosity range

We recommend that you choose an operating viscosity (at operating temperature) in the optimal range for both the efficiency and service life of the unit, i.e.:

$$v_{opt.} = \text{optimal operating viscosity } 16 \dots 36 \text{ mm}^2/\text{s}$$

(based on the tank temperature in the case of open circuit applications).

Viscosity limits

The limiting values for viscosity are as follows:

$$v_{min} = 10 \text{ mm}^2/\text{s}$$

momentary, at max. permissible leakage oil temperature 90°C.

$$v_{max} = 1000 \text{ mm}^2/\text{s}$$

momentary, during cold starting.

Temperature range (see selection diagram)

$$t_{min} = -25^\circ\text{C}$$

$$t_{max} = 90^\circ\text{C}$$

Note that the max. fluid temperature must not be exceeded at any point (e.g. around the bearings).

Filtration of hydraulic fluid

The finer the filtration, the higher the degree of purity achieved for the hydraulic fluid and the longer the service life of the axial piston unit. To ensure correct functioning of the axial piston unit, the following minimum purity grade for the hydraulic fluid is required:

9 to NAS 1638

18/15 to ISO/DIS 4406.

If the grades specified above cannot be maintained, please consult us.

Notes on the selection of hydraulic fluid

In order to select the correct hydraulic oil, it is necessary to know the operating temperature (open circuit: tank temperature) as a function of the ambient temperature.

The hydraulic oil should be selected so that in the operating temperature range the operating viscosity lies within the optimal range ($v_{opt.}$) – see shaded area of the selection graph. We recommend you to select the higher viscosity grade in each case.

Example:

at an ambient temperature of X°C, an operating temperature (open circuit: tank temperature) of 60°C is established.

In the optimal viscosity range ($v_{opt.}$, shaded area), this temperature corresponds to viscosity grades VG 46 or VG 68. Select VG 68.

Important:

The leakage oil temperature is influenced by pressure and speed and is typically higher than the tank temperature. However, the temperature must not exceed the maximum of 90°C at any point in the system.

If it is not possible to comply with the above conditions on account of extreme operating parameters or high ambient temperatures, we recommend that the housing be flushed via port U.

Long-life bearings (L)

(For long service life and when using HF fluids)

The external dimensions of the axial piston pump are identical with those of the version with mechanical bearings. Long-life bearings may be retrofitted in existing units. It is recommended that the bearings be flushed via port U.

Flushing

Quantities (recommended)

Size	250	355	500	1000
q_{Rinse} (L/min)	10	16	20	25

Selection chart

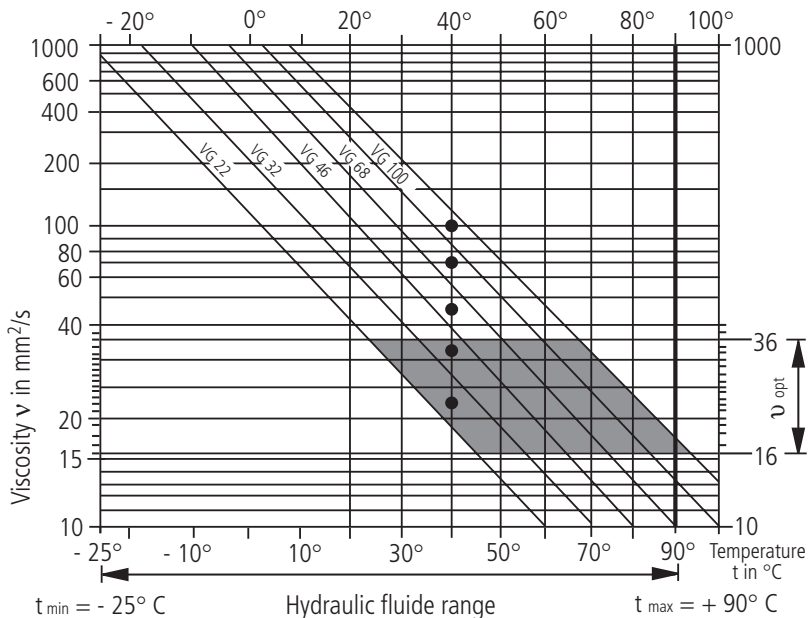

Technical data

(Valid for mineral oil operation; for water-based fluids see RE 90223, for ecologically acceptable fluids see RE 90221)

Input operating pressure range

Absolute pressure at port S (suction port)

$p_{abs\ min}$ _____ 0,8 bar
 $p_{abs\ max}$ _____ 8 bar

The input pressure determines the starting point of the **LR** power characteristic as well as of the **LR.H** and **LR.N** control characteristic.

Start of control is set by the manufacturer at $p_{abs} = 1$ bar.

An increase of input pressure causes an increase of control start and therefore produces a parallel shift in the control characteristic.

Detailed informations of the change on request.

Output operating pressure range

Pressure at port A or B

Nominal pressure p_N _____ 350 bar

Peak pressure p_{max} _____ 400 bar

(Pressure data to DIN 24312)

We recommend the use of a splined shaft (DIN 5480) for oscillating loads over 315 bar.

Direction of flow

Clockwise **S** to **B**

Anticlockwise **S** to **A**

Symbol

(without control)

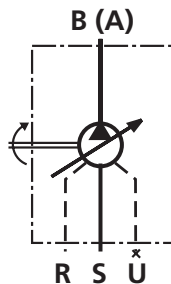

Ports

- B (A) Service lines
- S Suction port
- R Case drain fluid
- U Flushing port (For flushing the bearings)

Determination of input pressure p_{abs} at suction port S or reduction of displacement with increasing speed.

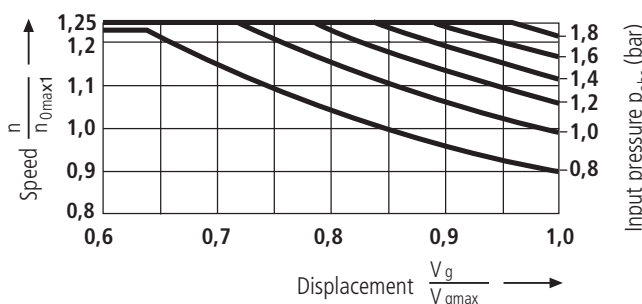

Case drain pressure

The lower the speed and case drain pressure, the longer the service life of the shaft seal.

FKM (fluoride rubber) shaft seal

The values specified in the diagram are permissible limit values for intermittent pressure loads acting on the shaft seal and should not be exceeded.

The service life of the shaft seal is reduced when subjected to purely stationary pressure loads close to the max. permissible case drain pressure.

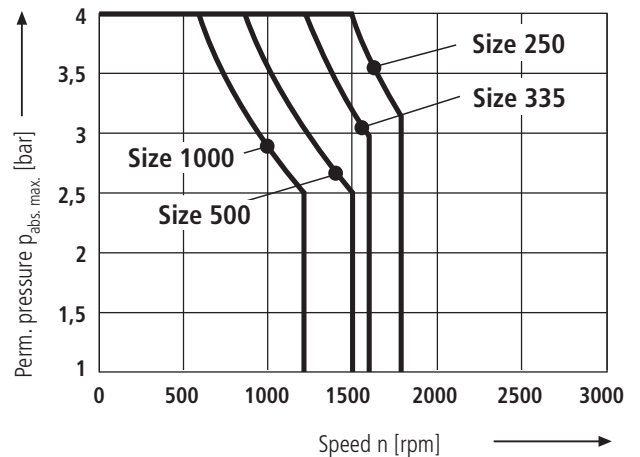

Special operating conditions may make it necessary to restrict these values.

Important:

- Max. permissible speeds of variable displacement pump (see table of values on page 6)
- Max. permissible housing pressure $p_{abs,max}$ _____ 4 bar
- The housing pressure determines the starting point of the **HD** and **DR** control characteristic.
 Start of control is set by the manufacturer at $p_{abs} = 1$ bar.
 An increase of the housing pressure causes an increase of control start and therefore produces a parallel shift in the control characteristic.
 Detailed informations of the change on request.
- The housing pressure must be equal or greater than the external pressure on the shaft seal.

Installation position

Can be installed in any position. The pump housing must be filled with hydraulic fluid before commissioning and must remain filled during operation. The drain line must be routed so that the housing is not drained when the pump is stationary, i.e. the end of the drain line must be below the minimum oil level in the tank.

The highest drain port R must always be used for filling the housing and for connecting the drain line. R_1 or R_2 must be connected.

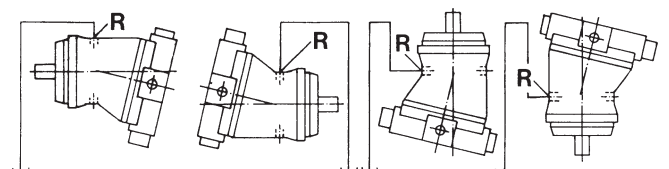

Technical data

Table of values (theoretical values, regardless of η_{mh} and η_v ; approximate values)

Size	Size		250	355	500	1000	
Displacement	$V_{g \max}^1)$	cm ³	250	355	500	1000	
	$V_{g \min}^1)$	cm ³	0	0	0	0	
Max. speed ²⁾	at $V_{g \max}$	$n_{o \max 1}$	rpm	1500	1320	1200	950
Max. permissible speed (speed limit) when $V_g < V_{g \max}$ or with higher input pressure p_{abs} at suction port S (see diagram on page 5)		$n_{o \max \text{perm.}}$	rpm	1800	1600	1500	1200
Max. flow ³⁾	at $n_{o \max 1}$ ($V_{g \max}$)	$q_{vo \max 1}$	L /min	364	455	582	922
Max. power ($\Delta p = 350$ bar)	at $q_{vo \max 1}$	$P_{o \max 1}$	kW	212	265	340	538
Permissible torque at $V_{g \max}$	in continuous operation ($\Delta p = 350$ bar)	T_{\max}	Nm	1391	1976	2783	5565
Moment of inertia about the drive axis		J	kgm ²	0.061	0.102	0.178	0.55
Weight, approx.		m	kg	102	173	234	450
Capacity		L		3	5	7	
Permissible loading of drive shaft: ⁴⁾							
Max. permissible axial force (at $p_{A,B}=1$ bar)	$+ F_{ax \max}$	N	4000	5000	6250	10000	
	$- F_{ax \max}$	N	1200	1500	1900	2600	
Max. permissible radial force (at $p_{A,B}=1$ bar) ⁵⁾	$F_{q \max}$	N	1200	1500	1900	2600	

¹⁾ Standard setting for limitation of the swivel angle. Please specify in plain text if a different setting is required.

Setting ranges $V_{g \max}$: $V_{g \max}$ to $0.8 V_{g \max}$

$V_{g \min}$: 0 to $0.2 V_{g \max}$

²⁾ The values apply for an absolute pressure (p_{abs}) of 1 bar

³⁾ Including 3% flow losses

⁴⁾ When stationary or during pressureless circulation of the axial piston unit

⁵⁾ Please consult us in cases with combined loads (axial and radial forces) and higher operating pressures (higher values are permissible in such cases)

Forces

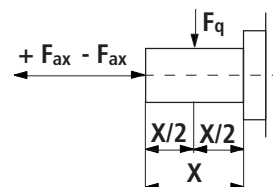

Determination of size

Flow	$q_v = \frac{V_g \cdot n \cdot \eta_v}{1000}$	[L/min]	V_g = Geometric displacement [cm ³] per revolution
Drive torque	$T = \frac{1.59 \cdot V_g \cdot \Delta p}{100 \cdot \eta_{mh}}$	[Nm]	Δp = Differential pressure [bar]
			n = Speed [rpm]
			η_v = Volumetric efficiency
			η_{mh} = Mechanical-hydraulic efficiency
Drive power	$P = \frac{2 \pi \cdot T \cdot n}{60000} = \frac{T \cdot n}{9549} = \frac{q_v \cdot \Delta p}{600 \cdot \eta_t}$	[kW]	η_t = Total efficiency ($\eta_t = \eta_v \cdot \eta_{mh}$)

Unit dimensions, size 250

Before finalising your design, please request certified assembly drawing.
Subject to change without notice.

(not including control)

Ports **A (B)** and **S** on opposite sides **02**

Clockwise rotation

Splined shaft
W50x2x30x24x9g
DIN 5480

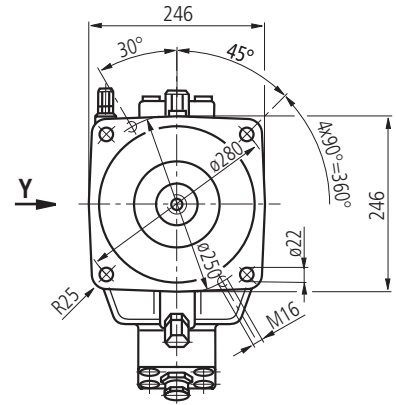
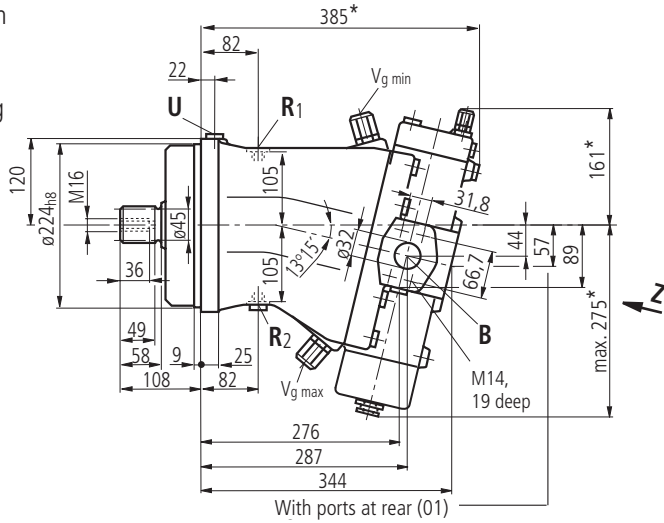

* See control devices

View Y

View Z, clockwise rotation

View Z, anticlockwise rotation

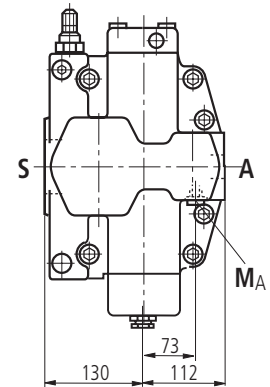
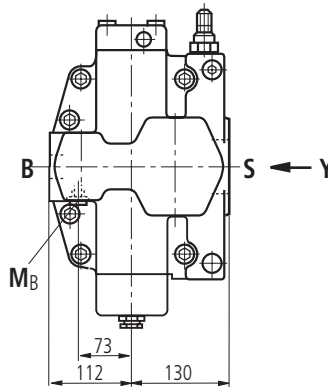
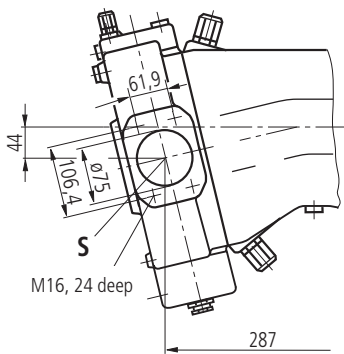

Variation

Shaft end **P**

Key AS 14 x 9 x 80

DIN 6885

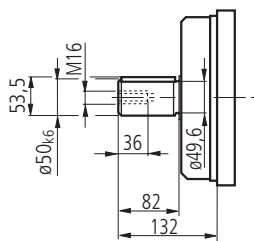

Variation

Ports **A (B)** and **S** at rear **(01)**

View Z, clockwise rotation

View Z, anticlockwise rotation

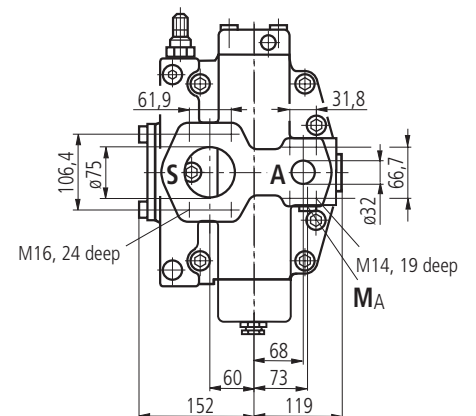
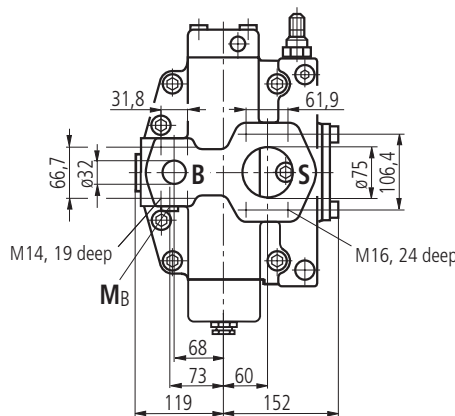

Ports

A,B Pressure ports

S Suction port

U Flushing port

R_{1,2} Case drain port

M_A, M_B Measuring ports (operating pressure)

SAE 1 1/4" (High-pressure series)

SAE 3" (Standard pressure series)

M 14 x 1.5 (Plugged by manufacturer)

M 22 x 1.5 (**R₂** plugged by manufacturer)

M 14 x 1.5 (Plugged by manufacturer)

Unit dimensions, size 355

Before finalising your design, please request certified assembly drawing.
Subject to change without notice.

(not including control)

Ports **A (B)** and **S** on opposite sides **02**

Clockwise rotation

Splined shaft
W60x2x30x28x9g
DIN 5480

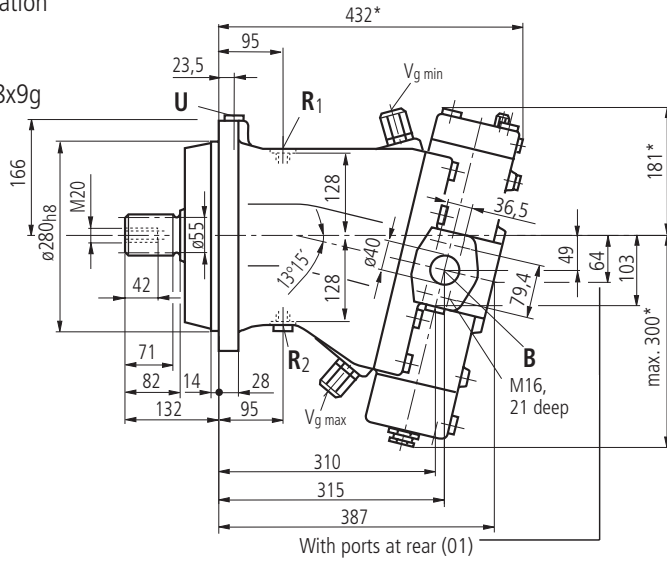

View Y

View Z, clockwise rotation

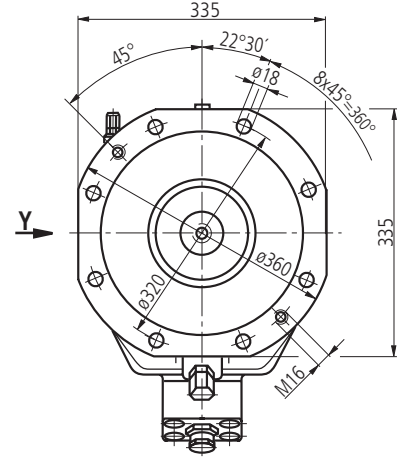

* See control devices

View Z, anticlockwise rotation

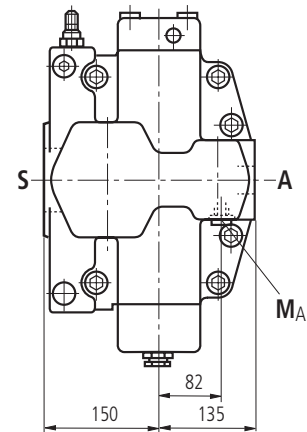
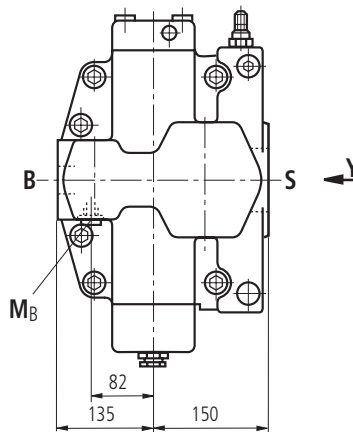
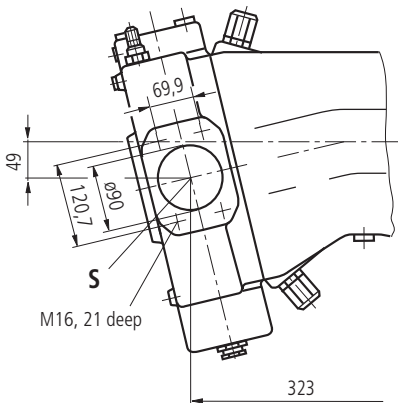

Variation

Shaft end **P**
Key AS 18 x 11 x 100
DIN 6885

Variation

Ports **A (B)** and **S** at rear **(01)**

View Z, clockwise rotation

View Z, anticlockwise rotation

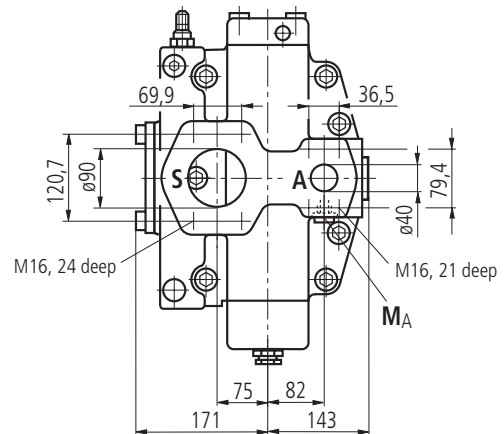
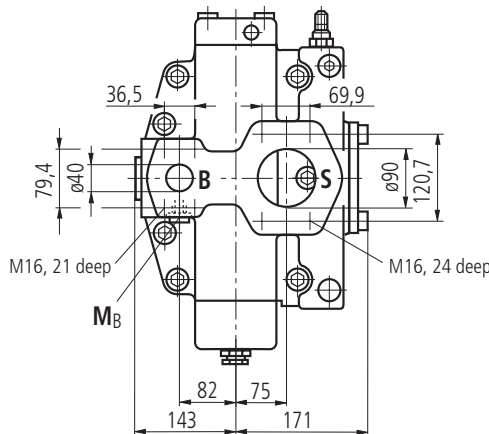
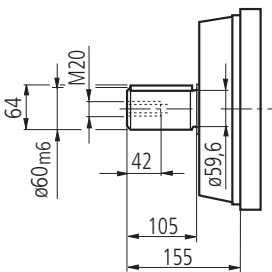

Ports

- | | | | |
|-------------------------------------|--------------------------------------|------------|---|
| A,B | Pressure ports | SAE 1 1/2" | (High-pressure series) |
| S | Suction port | SAE 3 1/2" | (Standard pressure series) |
| U | Flushing port | M 14 x 1.5 | (Plugged by manufacturer) |
| R_{1,2} | Case drain port | M 33 x 2 | (R₂ plugged by manufacturer) |
| M_A, M_B | Measuring ports (operating pressure) | M 14 x 1.5 | (Plugged by manufacturer) |

Unit dimensions, size 500

Before finalising your design, please request certified assembly drawing.
Subject to change without notice.

(not including control)

Ports **A (B)** and **S** on opposite sides **02**

Clockwise rotation

Splined shaft
W70x3x30x22x9g
DIN 5480

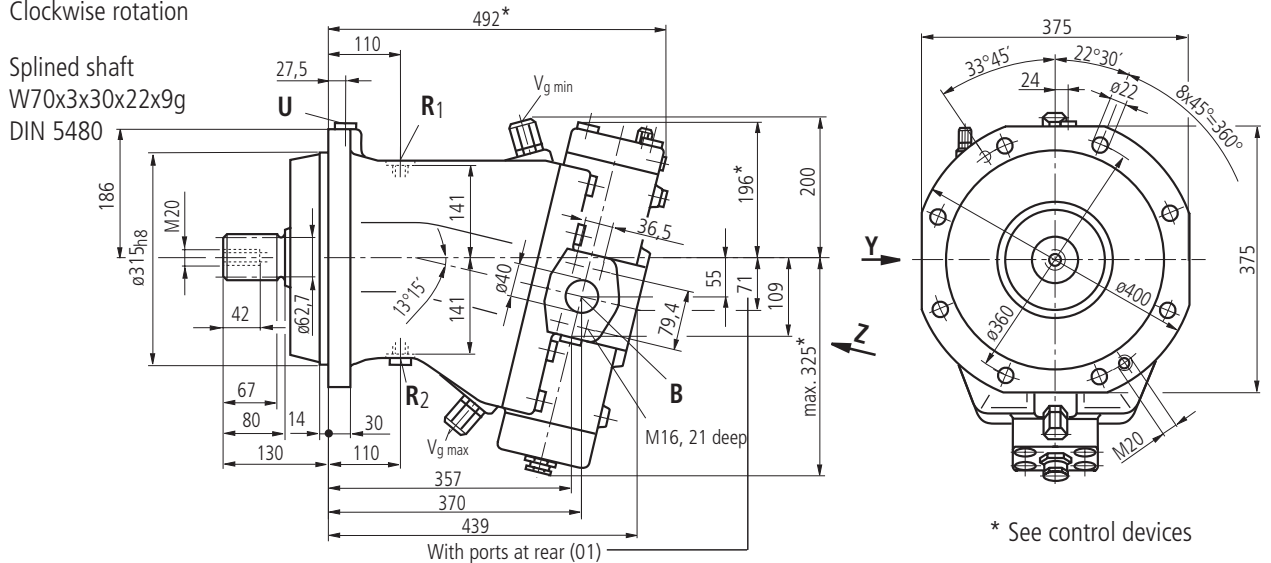

* See control devices

View Y

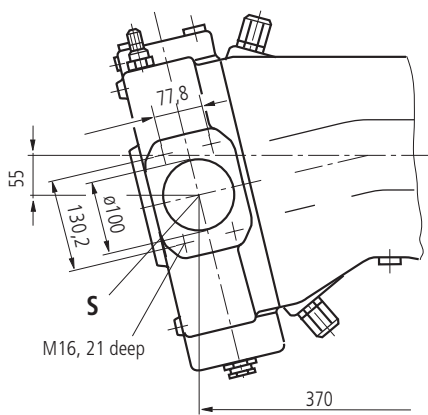

View Z, clockwise rotation

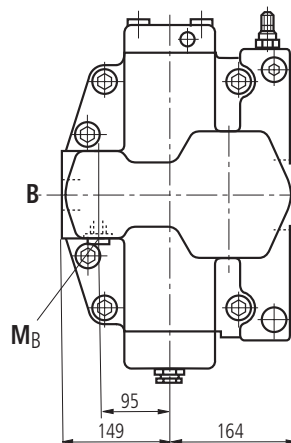

View Z, anticlockwise rotation

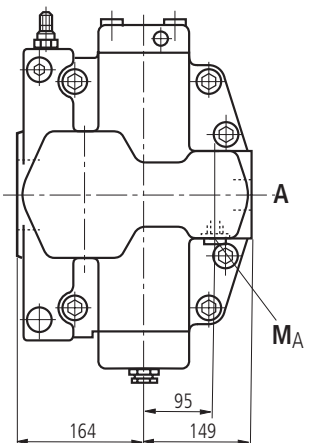

Variation

Shaft end P

Key AS 20 x 12 x 100

DIN 6885

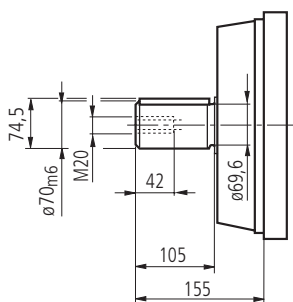

Variation

Ports **A (B)** and **S** at rear (01)

View Z, clockwise rotation

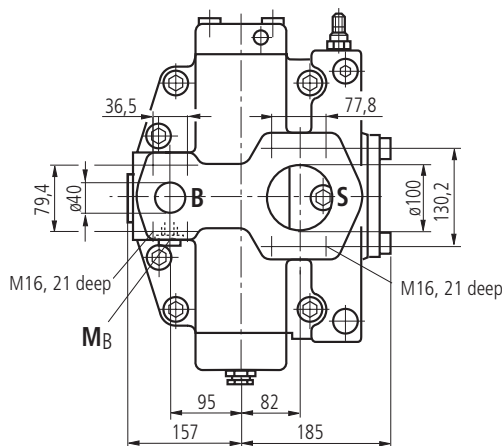

View Z, anticlockwise rotation

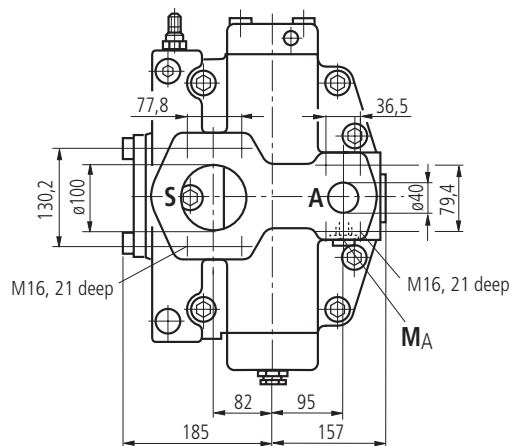

Ports

A, B Pressure ports

S Suction port

U Flushing port

R_{1,2} Case drain port

M_A, M_B Measuring ports (operating pressure)

SAE 1 1/2" (High-pressure series)

SAE 4" (Standard pressure series)

M 18 x 1.5 (Plugged by manufacturer)

M 33 x 2 (**R₂** plugged by manufacturer)

M 14 x 1.5 (Plugged by manufacturer)

Unit dimensions, size 1000

Before finalising your design, please request certified assembly drawing.
Subject to change without notice.

(not including control)
Ports **A (B) and S** at rear **01**
Anticlockwise rotation

Splined shaft
W90x3x30x28x9g
DIN 5480

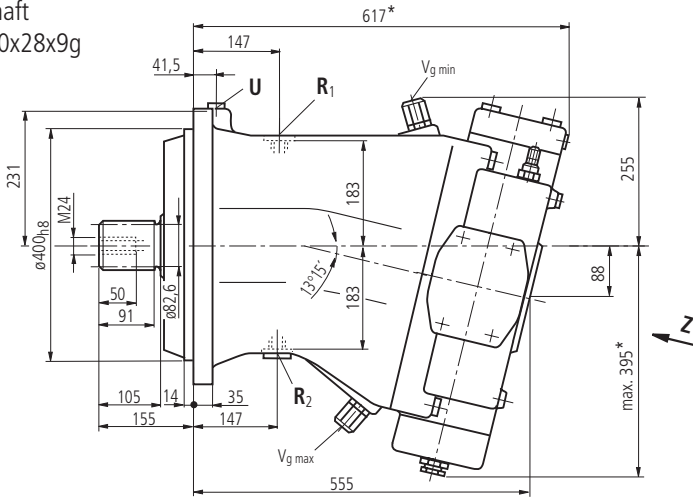

View Y

View Z, clockwise rotation

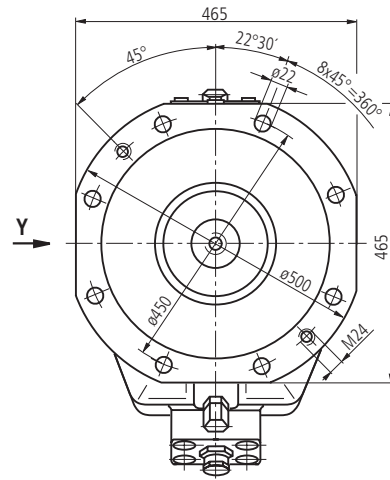

* See control devices

View Z, anticlockwise rotation

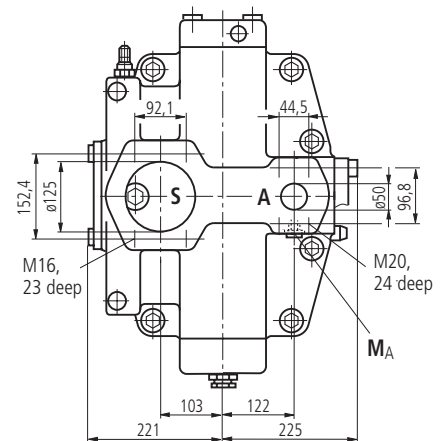
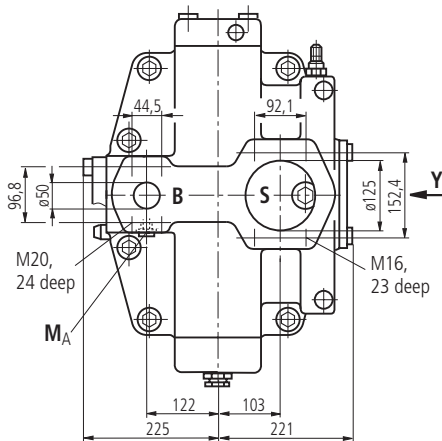
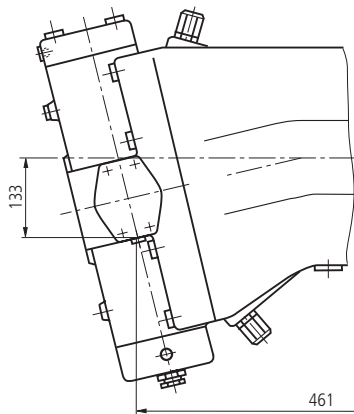

Variation

Shaft end **P**
Key AS 25 x 14 x 125
DIN 6885

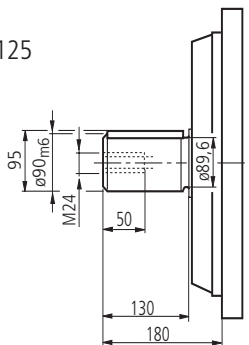

Ports

- | | | | |
|-------------------------------------|--------------------------------------|------------|---|
| A, B | Pressure ports | SAE 2" | (High-pressure series) |
| S | Suction port | SAE 5" | (Standard pressure series) |
| U | Flushing port | M 18 x 1.5 | (Plugged by manufacturer) |
| R_{1,2} | Case drain port | M 42 x 2 | (R₂ plugged by manufacturer) |
| M_A, M_B | Measuring ports (operating pressure) | M 14 x 1.5 | (Plugged by manufacturer) |

LRD Power controller, with integrated pressure control, initial setting V_{gmax}

Power control

The power controller permits optimum utilization of the drive power by matching it precisely with the hyperbolic characteristic.

The power controller adjusts the pump displacement in accordance with the operating pressure so that a given drive power is not exceeded at constant drive speed.

$$\text{Operating pressure } p \cdot \text{displacement } V_g = \text{constant drive power}$$

The operating pressure acts on a lever mechanism via the measuring spool in the positioning piston. It is offset by the externally set spring force which acts on the pilot valve and determines the power setting.

The pump is maintained at the maximum displacement V_{gmax} , since the operating pressure is also present on the small side of the piston.

When the operating pressure exceeds the set spring force, the pilot valve is actuated via the lever mechanism, the larger piston area is supplied with positioning pressure and the pump swivels towards the smaller displacement V_{gmin} . This in turn reduces the effective moment on the lever mechanism and the operating pressure can increase in the same ratio by which the output flow is reduced ($p \cdot V_g = \text{constant}$).

Power control can be set to start between 50 and 300 bar.

When ordering, please specify in plain text:

Drive power P (kW)

Drive speed n (rpm)

Max. flow q_{vmax} (L/min)

Characteristic

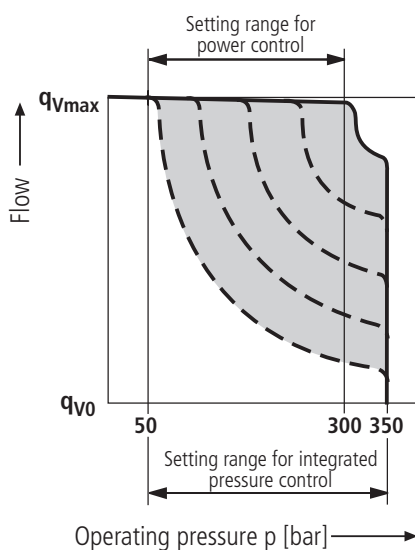

Power characteristics in kW

Size 250

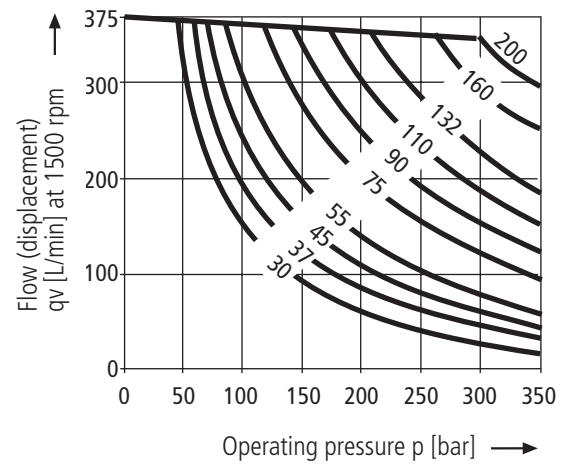

Size 355

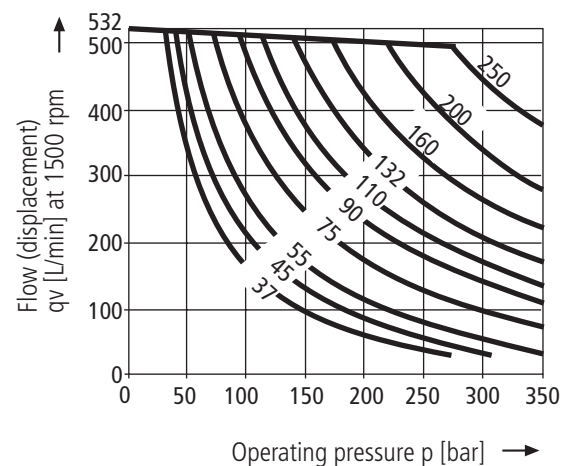

Size 500

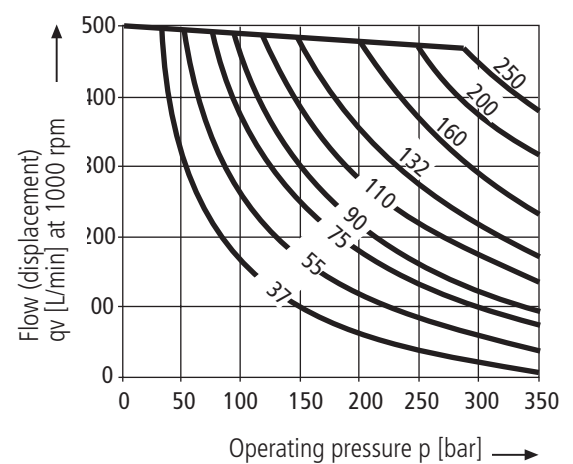

Integrated pressure control is supplied as standard and overrides the power control. Description see page 12.

Circuit diagram and unit dimensions, see page 12.

LRD Integrated pressure control, initial setting V_{gmax}

Before finalising your design, please request certified assembly drawing. Subject to change without notice.

Pressure control overrides power control.

It protects the pump against excessive pressure and damage.

The pressure control valve is integrated into the port plate and can be set externally.

The pump adjusts in direction of minimum displacement upon reaching the set required pressure.

Pressure control can be set to start between 50 and 350 bar.

Please specify the pressure control setting (bar) in plain text when ordering.

The pressure relief valve included in the system to safeguard the maximum pressure must have a cracking pressure at least 20 bar above the control setting.

Circuit diagram, power controller with integrated pressure control

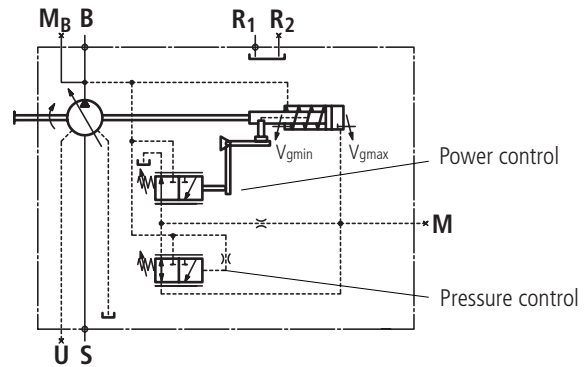

Unit dimensions

General dimensions on pages 7-9.

Clockwise rotation

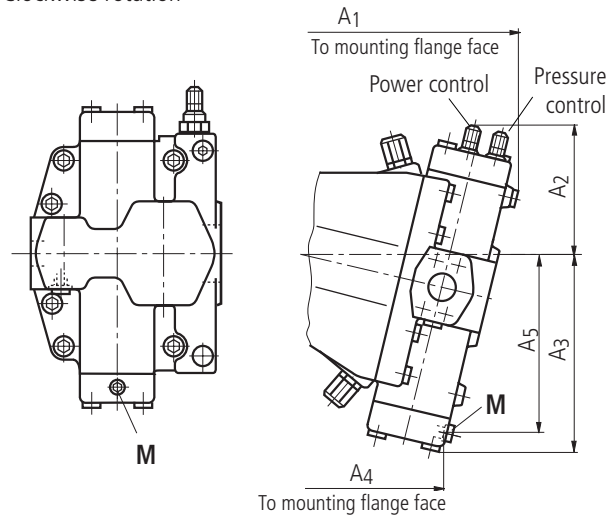

Anticlockwise rotation

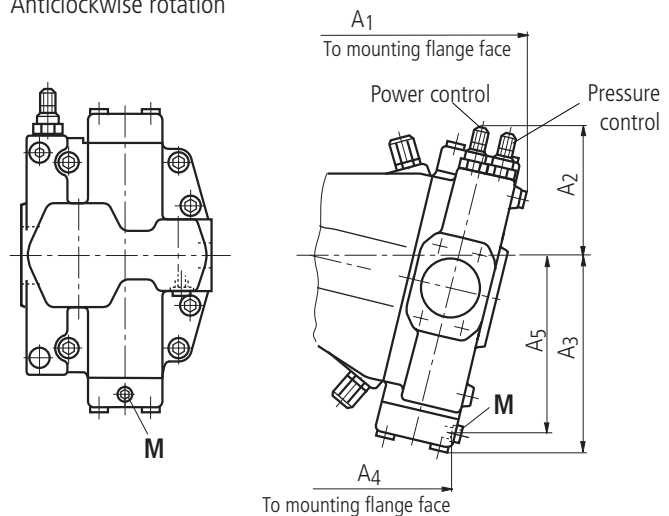

Characteristic

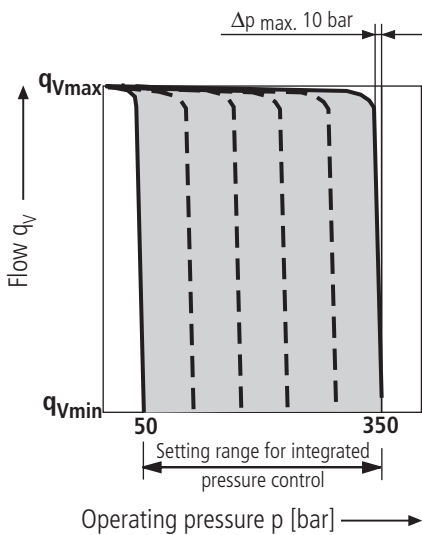

Ports

M Measuring ports (Positioning pressure) M 14 x 1.5 (plugged)

Unit dimensions

Size	A ₁	A ₂	A ₃	A ₄	A ₅
250	385	170	248	297	227
355	430	175	279	333	257
500	490	200	306	382	284

Variation LRG with remote-controlled pressure control, initial setting V_{gmax}

Before finalising your design, please request certified assembly drawing. Subject to change without notice.

The remote-controlled pressure control adjusts the pump in direction of minimum displacement V_{gmin} upon reaching the set required pressure.

It overrides the power control.

The integrated pressure control valve is controlled by a pressure relief valve (not supplied) which is located separate from the pump.

The integrated pressure control valve is uniformly supplied with pressure from both sides in addition to the spring force (pressure balance in a state of equilibrium) until the required pressure of the separate pressure limiting valve is reached.

The required pressure on the separate pressure limiting valve lies between 50 and 350 bar.

When the required pressure is reached on the separate pressure limiting valve, it opens and the pressure on the spring side of the integrated pressure control valve is reduced to tank. The integrated pressure control valve switches (pressure balance no longer in a state of equilibrium) and the pump swivels in direction of minimum displacement V_{gmin} .

The differential pressure on the integrated pressure control valve is set to 25 bar as standard. The consumption of control oil is then approx. 2 L/min. Please specify in plain text if a different setting (range 14 to 50 bar) is required.

The following are recommended for use as separate pressure limiting valve:

DBD 6 (hydraulic) as per RE 25402

DBETR-SO 437 with damped piston (electric) as per RE 29166

The max. line length should not exceed 2 m.

Circuit diagram, power controller with remote-controlled pressure control

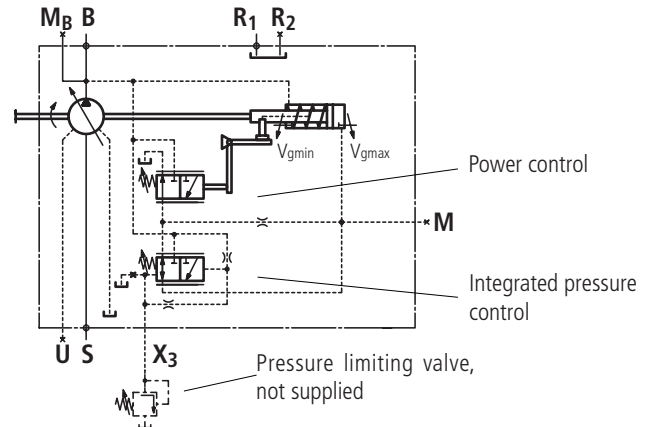

Unit dimensions

General dimensions on pages 7-9.

Clockwise rotation

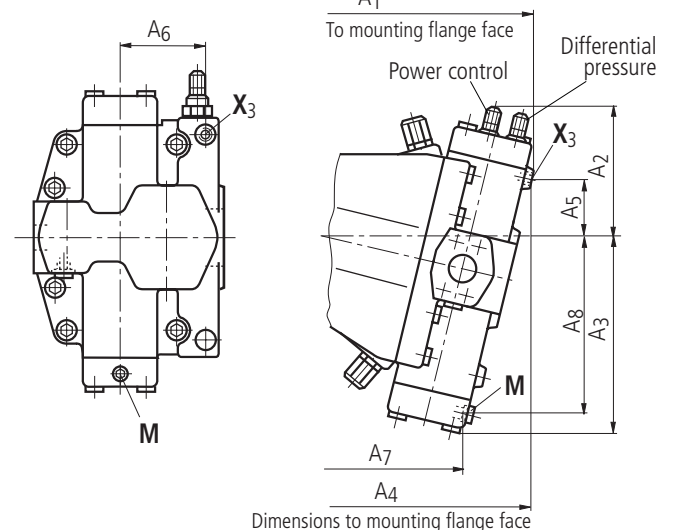

Anticlockwise rotation

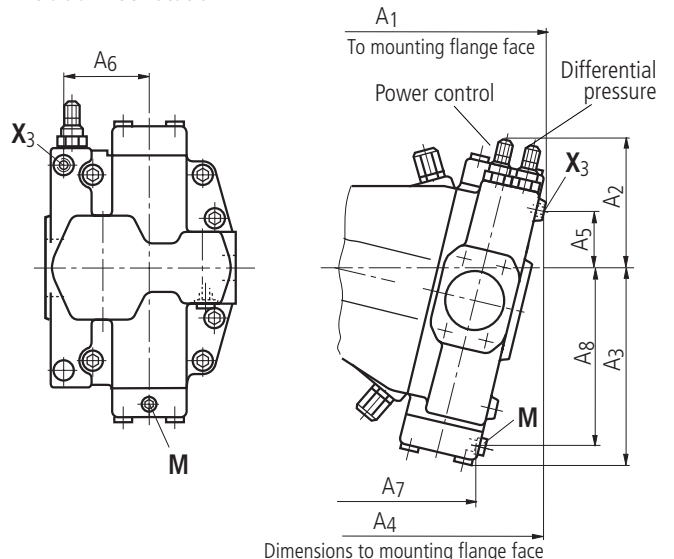

Characteristic

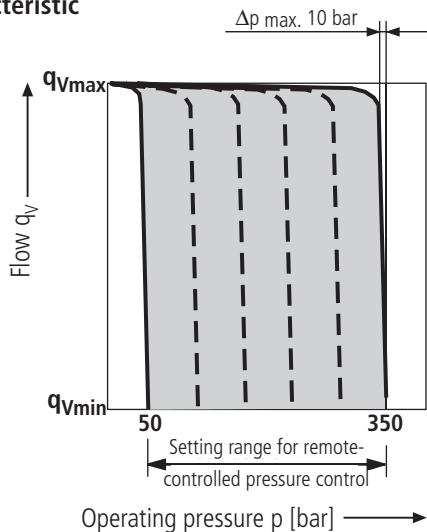

Ports

- X_3 Port for separate pressure limiting valve
- M Measuring port, positioning pressure (plugged)

Unit dimensions

Size	A_1	A_2	A_3	A_4	A_5	A_6	A_7	A_8	Ports X_3, M
250	385	170	248	380	74	112	297	227	M14 x 1.5
355	430	175	279	425	82	131	333	257	M14 x 1.5
500	490	200	306	483	96	142	382	284	M14 x 1.5

Variation LRDH with hydraulic stroke limitation, initial setting V_{gmax}

Before finalising your design, please request certified assembly drawing. Subject to change without notice.

Hydraulic stroke limitation is used for infinite adjustment of the flow between V_{gmax} and V_{gmin} .

It is overridden by the power control.

Displacement is set by the pilot pressure applied at port X_1 .

Max. permissible pilot pressure p_{Stmax} _____ 100 bar

Control oil loss _____ approx. 0.3 L/min

Hydraulic pressure limitation takes the required positioning pressure from the high pressure. It must be noted that the operating pressure requires at least 40 bar.

If the pressure is lower, the pump must be supplied with an external positioning pressure of at least 40 bar via port X_2 .

The start of control can be adjusted.

Please specify the start of control (bar) in plain text when ordering.

H1 Δp_{St} for hydraulic stroke adjustment _____ 10 bar

Start of control, variable _____ 2 - 20 bar

Standard setting for start of control _____ 5 bar

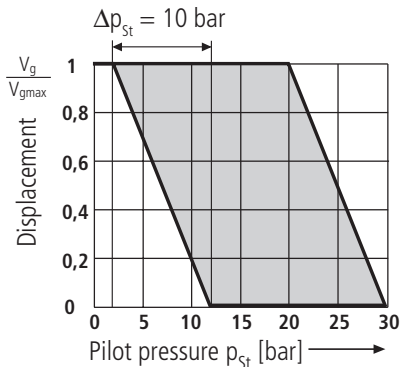

H2 Δp_{St} for hydraulic stroke adjustment _____ 25 bar

Start of control, variable _____ 5 - 50 bar

Standard setting for start of control _____ 10 bar

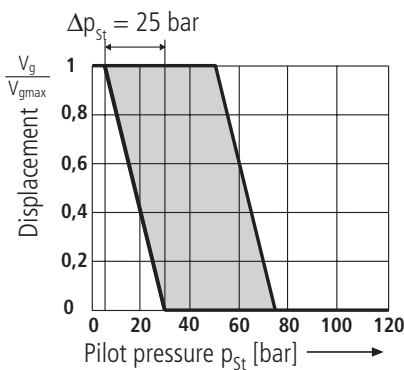

H3 Δp_{St} for hydraulic stroke adjustment _____ 35 bar

Start of control, variable _____ 7 - 50 bar

Standard setting for start of control _____ 10 bar

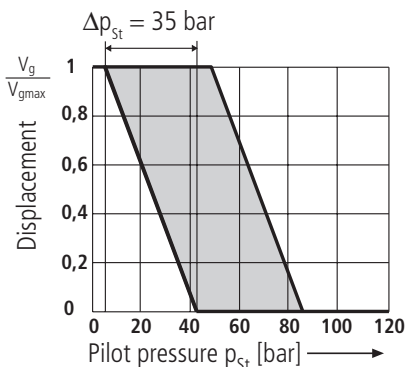

Circuit diagram, power controller with integrated pressure control and hydraulic stroke limitation H

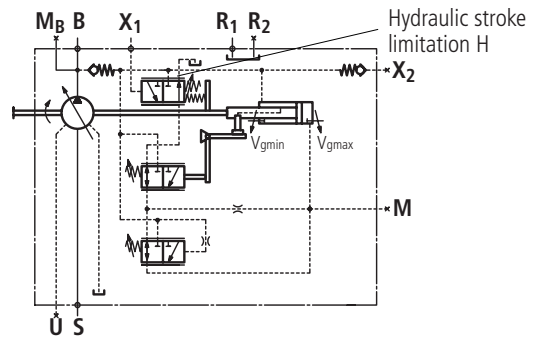

Unit dimensions

General dimensions on pages 7-9.

Clockwise rotation

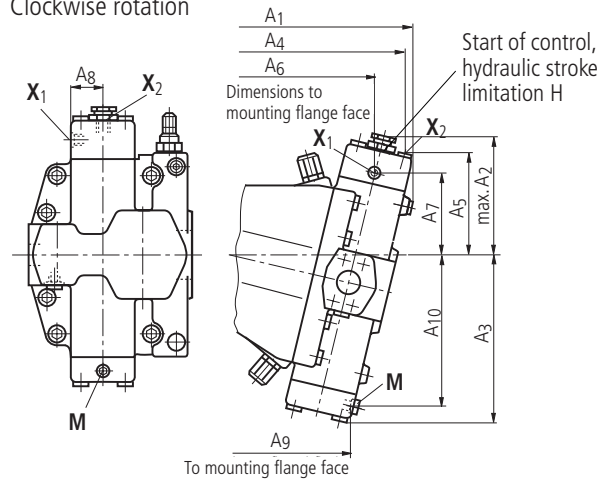

Anticlockwise rotation

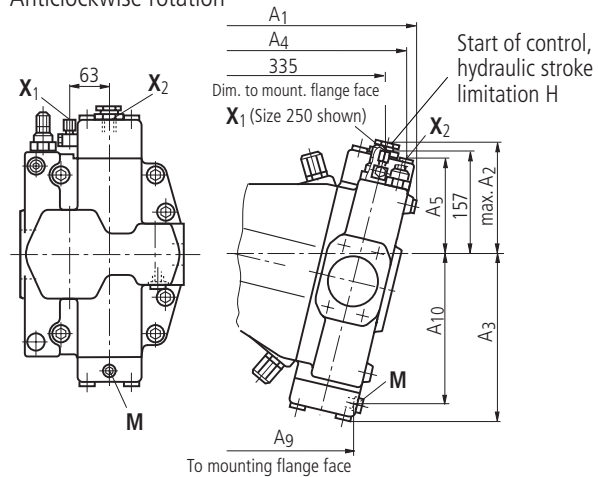

Port X_1 ,
Anticlockwise rotation
Size 355-500

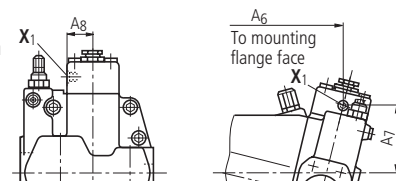

Ports, see page 15.

Unit dimensions

Ports

Size	A ₁	A ₂	A ₃	A ₄	A ₅	A ₆	A ₇	A ₈	A ₉	A ₁₀	X ₁ *, M	X ₂
250	385	188	248	370	144	327	123	49	297	227	M 14 x 1.5	M 14 x 1.5
355	432	203	279	416	157	366	137	54	333	257	M 14 x 1.5	M 14 x 1.5
500	490	215	306	470	169	417	148	61.5	382	284	M 14 x 1.5	M 18 x 1.5

* For size 250 and anticlockwise rotation, flared screw fitting BO-RSWW 8SMWD pipe dia. 8 DIN 2391

Variation LRDN with hydraulic stroke limitation, initial setting V_{gmin}

Before finalising your design, please request certified assembly drawing. Subject to change without notice.

Hydraulic stroke limitation is used for infinite adjustment of the flow between V_{gmin} and V_{gmax} .

It is overridden by the power control.

Displacement is set by the pilot pressure applied at port X_1 .

Max. permissible pilot pressure p_{Stmax} _____ 100 bar

Control oil loss _____ approx. 0.3 L/min

A pressure of 40 bar is required for hydraulic stroke limitation. The required positioning oil is taken from the high pressure side.

An external positioning pressure is not required when the operating pressure > 40 bar and $V_{gmin} > 0$. Port X_2 must be plugged before commissioning in this case. In all other cases, an external positioning pressure of at least 40 bar must be connected to port X_2 .

The start of control can be varied.

Please specify the start of control (bar) in plain text when ordering.

N1 Δp_{St} for hydraulic stroke adjustment _____ 10 bar

Start of control, variable _____ 2 - 20 bar

Standard setting for start of control _____ 5 bar

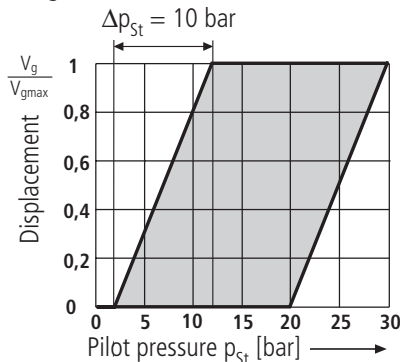

N2 Δp_{St} for hydraulic stroke adjustment _____ 25 bar

Start of control, variable _____ 5 - 50 bar

Standard setting for start of control _____ 10 bar

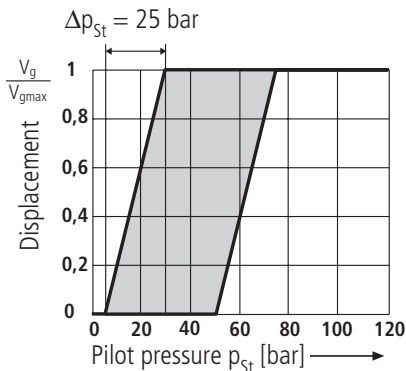

N3 Δp_{St} for hydraulic stroke adjustment _____ 35 bar

Start of control, variable _____ 7 - 50 bar

Standard setting for start of control _____ 10 bar

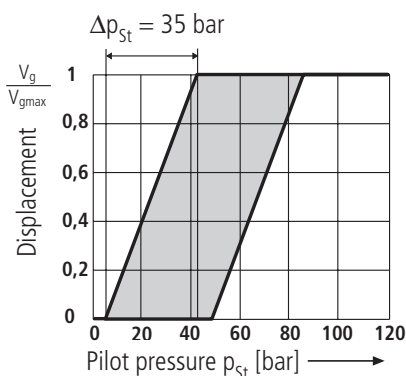

Circuit diagram, power controller with integrated pressure control and hydraulic stroke limitation N

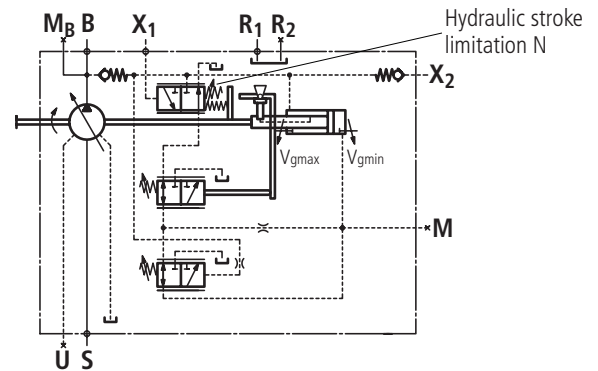

Unit dimensions

General dimensions on pages 7-9.

Clockwise rotation

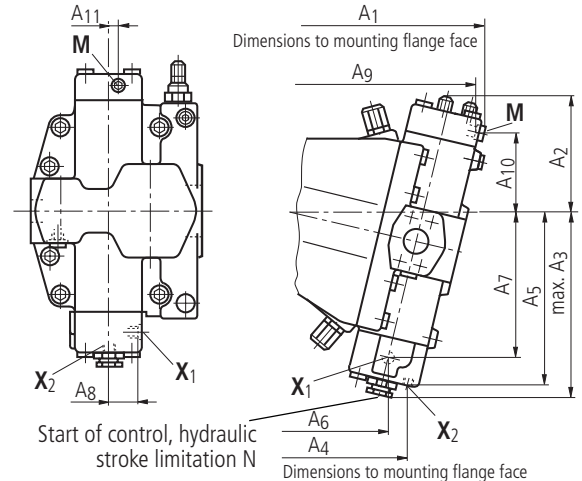

Anticlockwise rotation

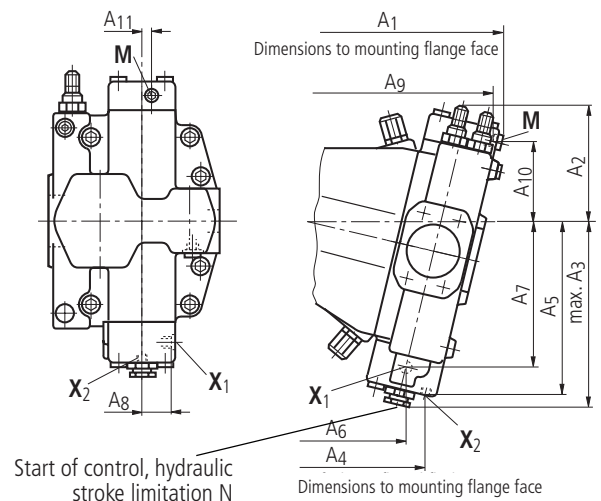

Ports

X₁ Pilot pressure port

X₂ External positioning pressure port (plugged in variation LR.H)

M Measuring port, positioning pressure (plugged)

Unit dimensions

Ports

Size	A ₁	A ₂	A ₃	A ₄	A ₅	A ₆	A ₇	A ₈	A ₉	A ₁₀	A ₁₁	X ₁	M	X ₂
250	385	170	275	276	248	248	210	49	377	116	14	M14 x 1.5	M14 x 1.5	
355	430	175	300	315	275	278	234	54	425	132	20	M14 x 1.5	M14 x 1.5	
500	492	200	325	359	300	322	258	61.5	483	144	20	M14 x 1.5	M18 x 1.5	

DR Pressure controller, initial setting V_{gmax}

Before finalising your design, please request certified assembly drawing. Subject to change without notice.

The pressure controller maintains the pressure in a hydraulic system constant within its control range despite the changing pump flow requirements. The variable displacement pump supplies only the volume of fluid required by the consumers. The pump automatically adjusts in direction of minimum displacement when the operating pressure exceeds the required pressure set on the integrated pressure control valve.

Pressure control can be set to start between 50 and 350 bar.

Please specify the pressure control setting (bar) in plain text when ordering.

A pressure relief valve included in the system to safeguard the maximum pressure must have a cracking pressure at least 20 bar above the control setting.

Circuit diagram, pressure controller

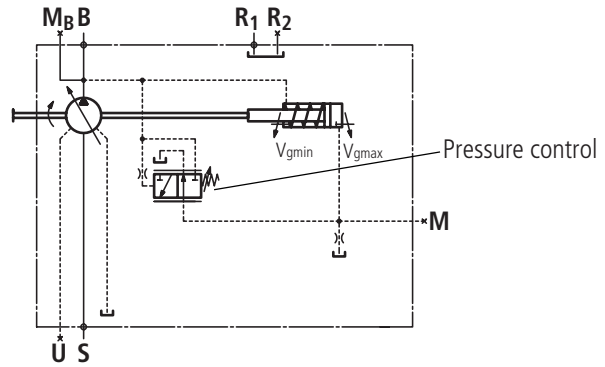

Unit dimensions

General dimensions on pages 7-9.

Clockwise rotation

Characteristic

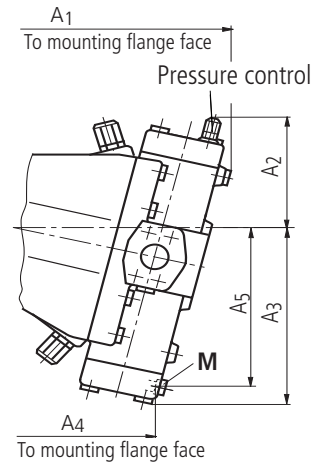
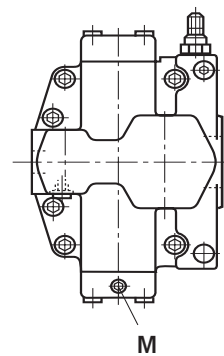
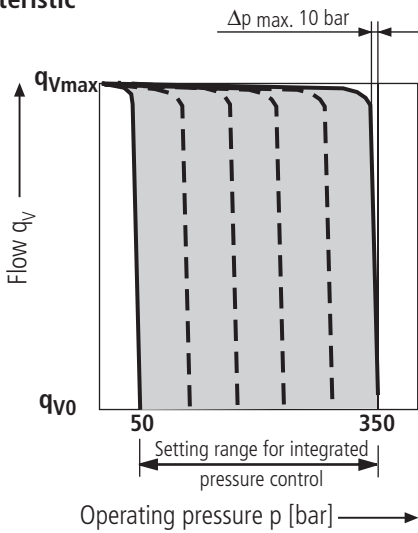

Anticlockwise rotation

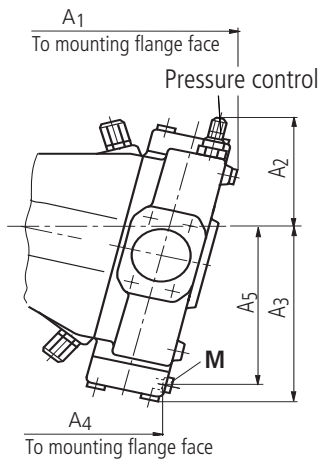
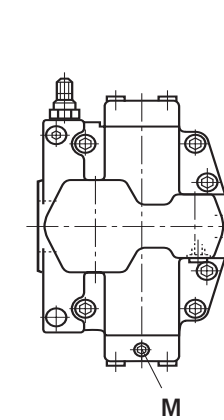

Ports

M Measuring ports (Positioning pressure) M 14 x 1.5 (plugged)

Unit dimensions

Size	A ₁	A ₂	A ₃	A ₄	A ₅
250	385	161	248	297	227
355	430	175	279	333	257
500	490	200	306	382	284

Variation DRG Remote-controlled pressure control, initial setting V_{gmax}

Before finalising your design, please request certified assembly drawing. Subject to change without notice.

Port X_3 is additionally installed for remote pressure control
 The pressure limiting valve located separately from the pump is connected to this port. The pressure limiting valve is not supplied with the DRG.

The integrated pressure control valve is uniformly supplied with pressure from both sides in addition to the spring force (pressure balance in a state of equilibrium) until the required pressure of the separate pressure limiting valve is reached.

The required pressure lies between 50 and 350 bar.

When the required pressure is reached on the separate pressure limiting valve, it opens and the pressure on the spring side of the integrated pressure control valve is reduced to tank. The integrated pressure control valve switches (pressure balance no longer in a state of equilibrium) and the pump swivels in direction of minimum displacement V_{gmin} .

The differential pressure on the integrated pressure control valve is set to 25 bar as standard. The consumption of control oil is then approx. 2 L/min. Please specify in plain text if a different setting (range 14 to 50 bar) is required.

The following are recommended for use as separate pressure limiting valve:

- DBD 6 (hydraulic) as per RE 25402
- DBETR-SO 437 with damped piston (electric) as per RE 29166

The max. line length should not exceed 2 m.

Characteristic

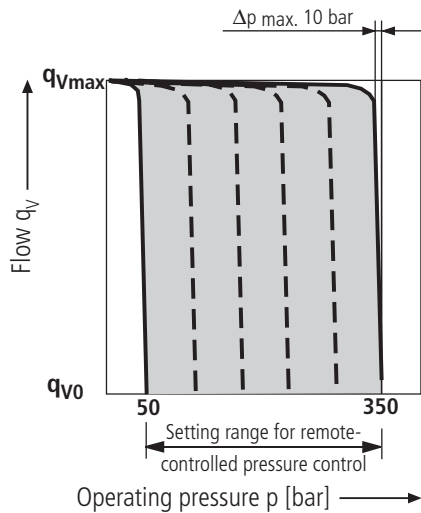

Ports

- X_3 Port for separate pressure limiting valve
- M Measuring port, positioning pressure (plugged)

Unit dimensions

Size	A_1	A_2	A_3	A_4	A_5	A_6	A_7	A_8	X_3, M
250	385	161	248	380	74	112	297	227	M 14 x 1.5
355	430	175	279	425	82	131	333	257	M 14 x 1.5
500	490	200	306	483	96	142	382	284	M 14 x 1.5

Circuit diagram, pressure controller with remote control

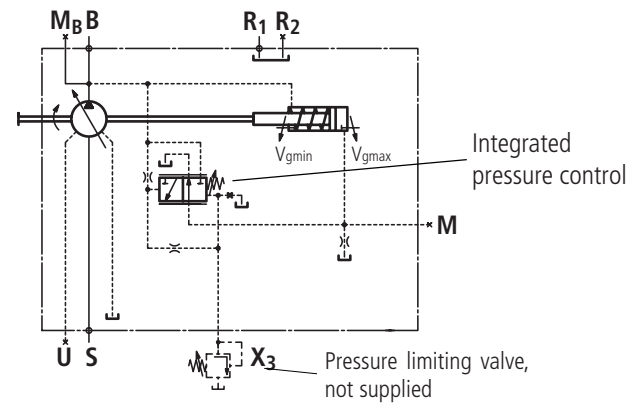

Unit dimensions

General dimensions on pages 7-9.

Clockwise rotation

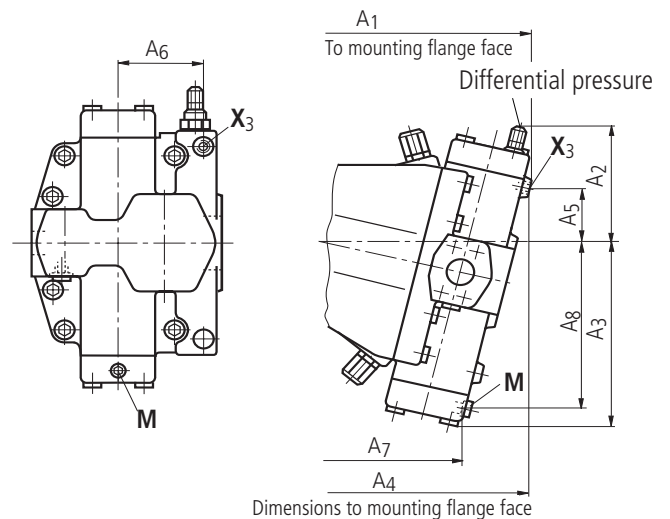

Anticlockwise rotation

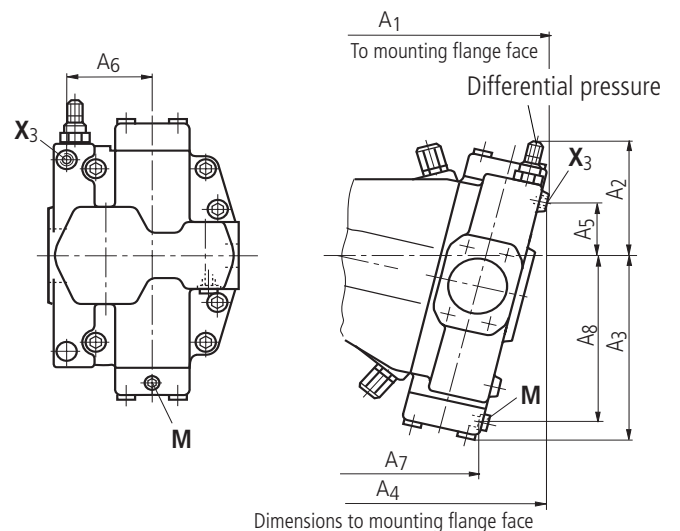

HD.D Hydraulic control, dependent on pilot pressure, initial setting V_{gmin}

Before finalising your design, please request certified assembly drawing. Subject to change without notice.

Pressure-dependent hydraulic control permits infinitely variable adjustment of the pump displacement in accordance with the pilot pressure. The adjustment is proportional to the pilot pressure applied to port X_1 . A pressure of 40 bar is required for adjustment. The required positioning oil is taken from the high pressure side.

An external positioning pressure is not required when the operating pressure > 40 bar and $V_{gmin} > 0$. Port X_2 must be plugged before commissioning in this case.

In all other cases, an external positioning pressure of at least 40 bar must be connected to port X_2 .

Max. permissible pilot pressure p_{Stmax} _____ 100 bar
Control oil loss _____ approx. 0.3 L/min

The start of control can be adjusted.

Please specify the start of control (bar) in plain text when ordering.

HD1D Δp_{St} _____ 10 bar
Start of control, variable _____ 2 - 20 bar
Standard setting for start of control _____ 5 bar

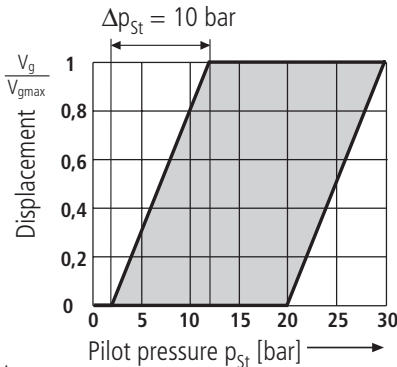

HD2D Δp_{St} _____ 25 bar
Start of control, variable _____ 5 - 50 bar
Standard setting for start of control _____ 10 bar

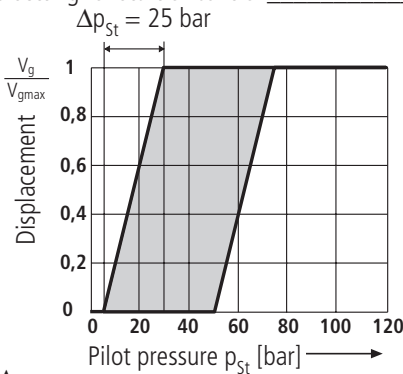

HD3D Δp_{St} _____ 35 bar
Start of control, variable _____ 7 - 50 bar
Standard setting for start of control _____ 10 bar

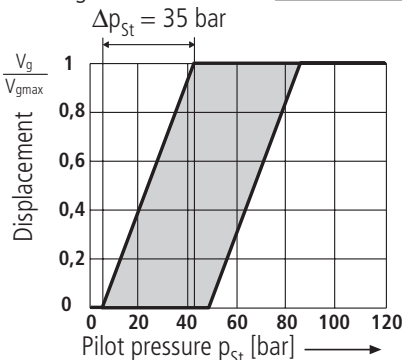

Integrated pressure control is supplied as standard
Description, see page 19.

Circuit diagram, hydraulic control dependent on pilot pressure

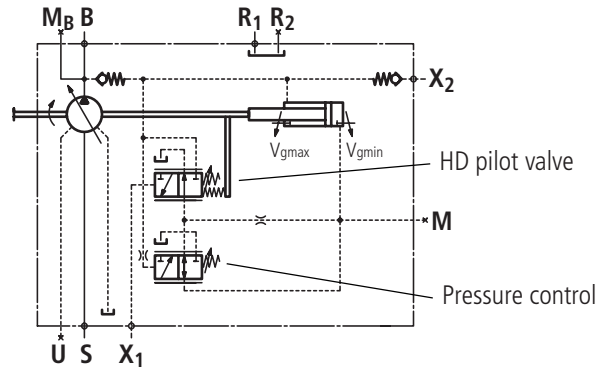

Unit dimensions

General dimensions on pages 7-10.

Clockwise rotation

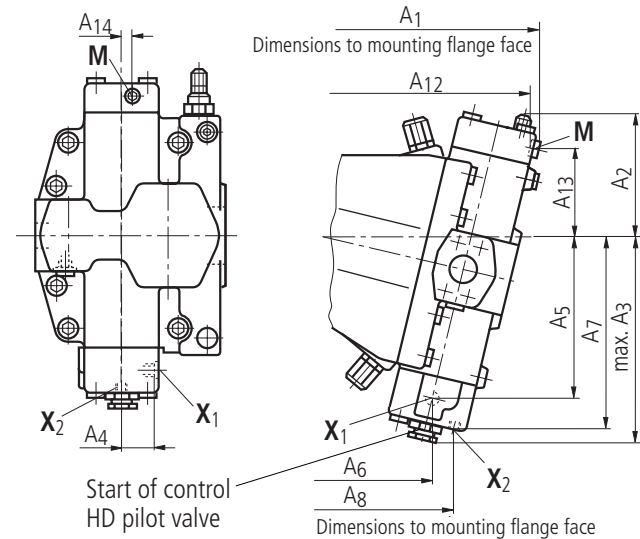

Anticlockwise rotation

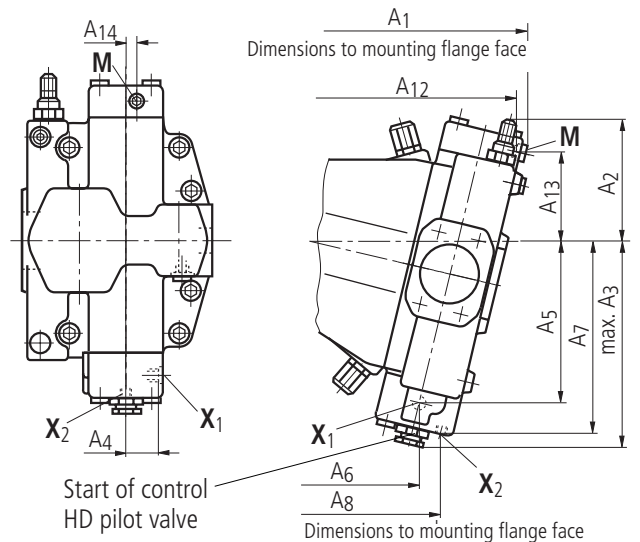

Table of dimensions and ports, see page 19.

HD.D Integrated pressure control / HD.G with remote-controlled pressure control, initial setting V_{gmin}

Before finalising your design, please request certified assembly drawing. Subject to change without notice.

HD.D

Pressure control overrides the HD function and protects the pump against excessive pressure and damage. The pressure control valve is integrated into the port plate and can be set externally. The pump adjusts in direction of minimum displacement upon reaching the set required pressure.

Pressure control can be set to start between 50 and 350 bar.

Please specify the pressure control setting (bar) in plain text when ordering.

The pressure relief valve included in the system to safeguard the maximum pressure must have a cracking pressure at least 20 bar above the control setting.

Circuit diagram, see page 18.

HD.G

The remote-controlled pressure control adjusts the pump in direction of minimum displacement V_{gmin} upon reaching the set required pressure.

The integrated pressure control valve is controlled by a pressure relief valve (not supplied) which is located separate from the pump.

The integrated pressure control valve is uniformly supplied with pressure from both sides in addition to the spring force (pressure balance in a state of equilibrium) until the required pressure of the separate pressure limiting valve is reached.

The required pressure lies between 50 and 350 bar.

When the required pressure is reached on the separate pressure limiting valve, it opens and the pressure on the spring side of the integrated pressure control valve is reduced to tank. The integrated pressure control valve switches (pressure balance no longer in a state of equilibrium) and the pump swivels in direction of minimum displacement V_{gmin} .

The differential pressure on the integrated pressure control valve is set to 25 bar as standard. The consumption of control oil is then approx. 2 L/min. Please specify in plain text if a different setting (range 14 to 50 bar) is required.

The following are recommended for use as separate pressure limiting valve: DBD 6 (hydraulic) as per RE 25402

DBETR-SO 437 with damped piston (electric) as per RE 29166

The max. line length should not exceed 2 m.

Circuit diagram, hydraulic control dependent on pilot pressure with remote-controlled pressure control

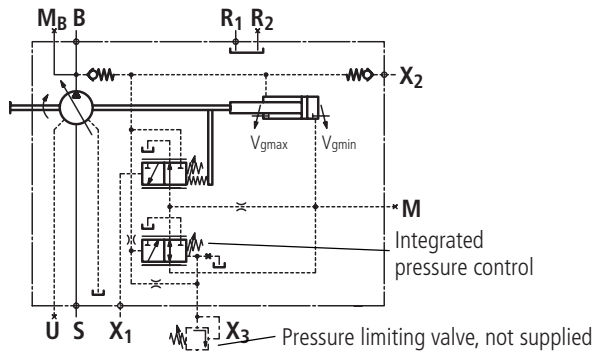

Ports

- X₁** Pilot pressure port
- X₂** External positioning pressure port
- X₃** Port for separate pressure limiting valve (HDG)
- M** Measuring port, positioning pressure (plugged)

Characteristic

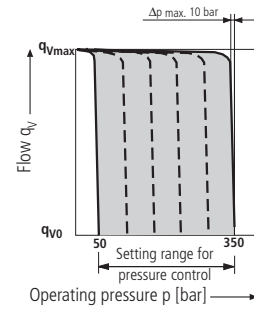

Unit dimensions

General dimensions on pages 7-10

Clockwise rotation

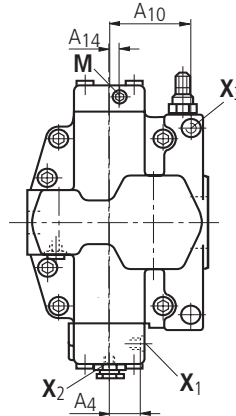

Pressure control (or differential pressure HDG)

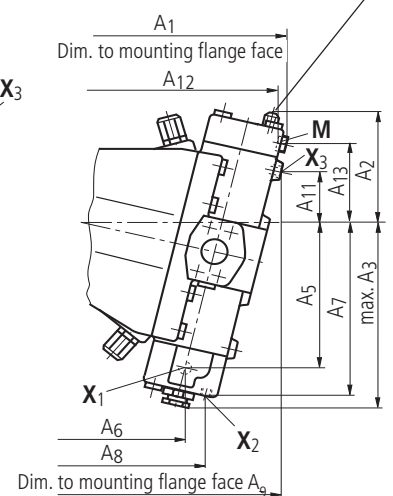

Anticlockwise rotation

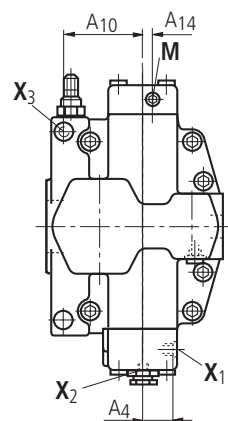

Pressure control (or differential pressure HDG)

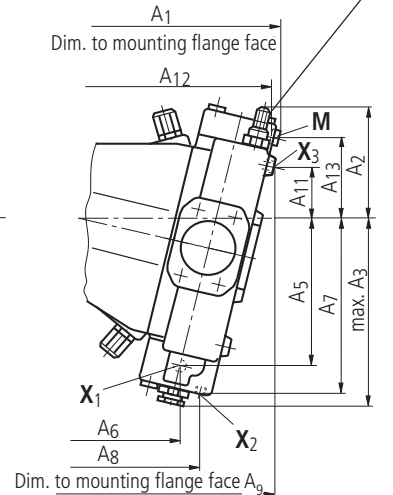

Unit dimensions

Size	A ₁	A ₂	A ₃	A ₄	A ₅	A ₆	A ₇	A ₈	A ₉	A ₁₀	A ₁₁
250	385	161	275	49	210	248	248	276	380	112	74
355	432	181	300	54	234	278	275	315	425	131	82
500	492	200	325	61.5	258	322	300	359	483	142	96
1000	617	255	395	70	325	416	371	462	599	176	84

Size	Ports					
	A ₁₂	A ₁₃	A ₁₄	X ₁	X ₂	X ₃ , M
250	377	116	14	M14x1.5	M14x1.5	M14x1.5
355	425	132	20	M14x1.5	M14x1.5	M14x1.5
500	483	144	20	M14x1.5	M18x1.5	M14x1.5
1000	610	180	25	M14x1.5	M18x1.5	M14x1.5

EP.D Hydraulic control with electrical proportional valve, initial setting V_{gmin}

Before finalising your design, please request certified assembly drawing. Subject to change without notice.

Hydraulic control permits infinitely variable adjustment of the pump displacement.

The displacement is set proportional to the current applied to the solenoid of the proportional pressure-reducing valve DRE 4 K (see RE 29181), i.e. the displacement increases with increasing current intensity.

Various amplifiers from the Rexroth range are available for controlling the proportional valve, see RE 29181.

A pressure of 40 bar is required for adjustment. The required positioning oil is taken from the high pressure side.

An external positioning pressure is not required when the operating pressure > 40 bar and $V_{gmin} > 0$. Port X_2 must be plugged before commissioning in this case.

In all other cases, an external positioning pressure of at least 40 bar must be connected to port X_2 .

A positioning pressure of 30 bar is required at port P to actuate the proportional valve DR4K.

Positioning pressure at port P

required p_{min} _____ 30 bar
 p_{max} _____ 100 bar

Model	Control voltage (DC)	Control current Start of control	End of control
EP1	12V	900mA	– 1400mA
EP2	24V	450mA	– 700mA

Type of protection IP 65

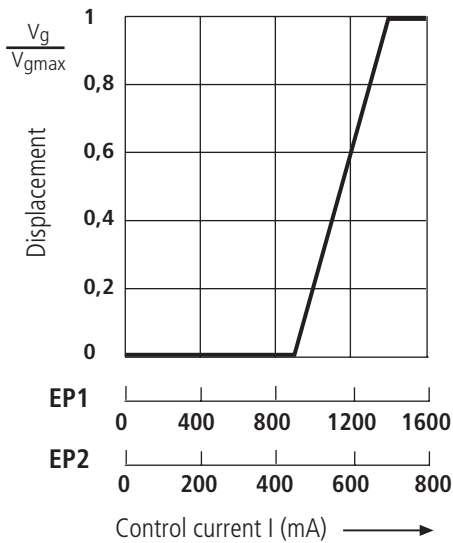

Integrated pressure control EP.D is supplied as standard and overrides EP. Description, see page 21.

Unit dimensions

Size	A_1	A_2	A_3	A_4	A_5	A_6	A_7	A_8	A_9	A_{10}	A_{11}	A_{12}
250	385	161	275	115	248	276	238	241	36	112	380	74
355	432	181	300	116	275	315	268	286	36	131	425	82
500	492	200	325	123	300	359	294	328	43	142	483	96

Size	Ports						X_2
	A_{13}	A_{14}	A_{15}	A_{16}	A_{17}	A_{18}	
250	377	116	14	248	210	49	M14x1.5
355	425	132	20	278	234	54	M14x1.5
500	483	144	20	322	258	61.5	M14x1.5

Circuit diagram, hydraulic control with electrical proportional valve

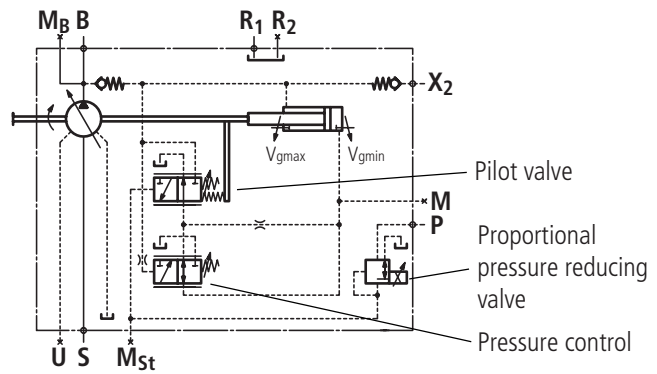

Unit dimensions

General dimensions on pages 7-9.

Clockwise rotation

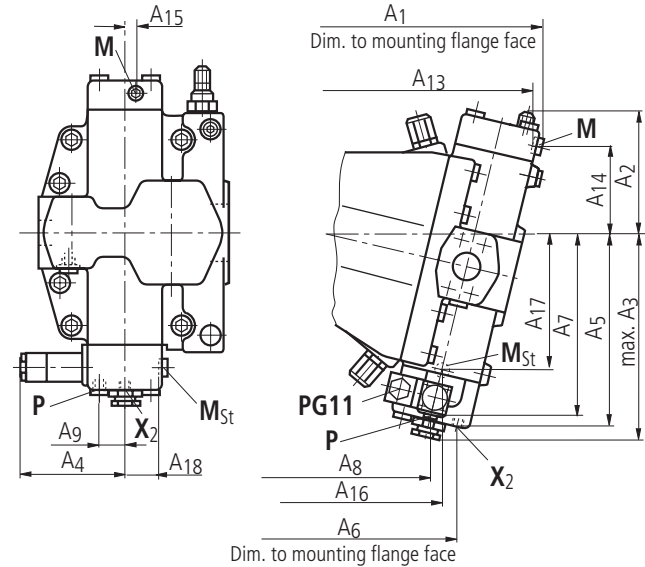

Anticlockwise rotation

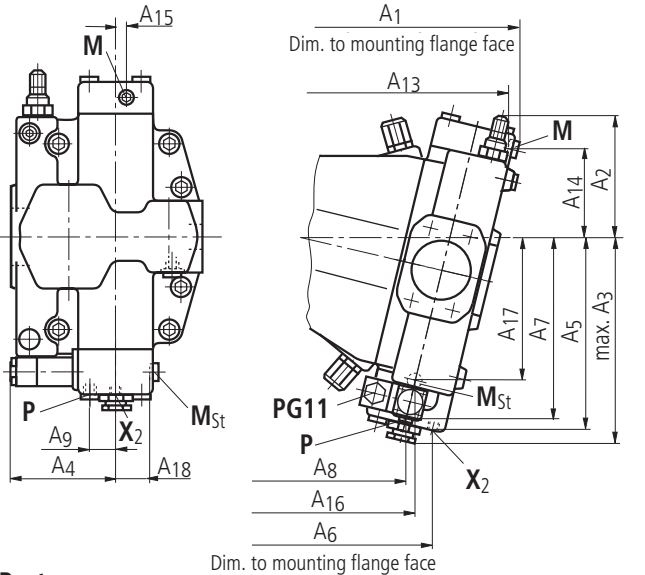

Ports

- P** Positioning pressure port
- X_2** External positioning pressure port
- X_3** Port for separate pressure limiting valve (EPG)
- M** Measuring port, positioning pressure (plugged)
- M_{St}** Measuring port, pilot pressure (plugged)

EP.D Integrated pressure control / EP.G with remote-controlled pressure control, initial setting V_{gmin}

Before finalising your design, please request certified assembly drawing. Subject to change without notice.

EP.D Integrated pressure control

Pressure control overrides the ED function and protects the pump against excessive pressure and damage. The pressure control valve is integrated into the port plate and can be set externally. The pump adjusts in direction of minimum displacement upon reaching the set required pressure.

Pressure control can be set to start between 50 and 350 bar.

Please specify the pressure control setting (bar) in plain text when ordering.

The pressure relief valve included in the system to safeguard the maximum pressure must have a cracking pressure at least 20 bar above the control setting.

Circuit diagram, see page 20.

EP.G with remote-controlled pressure control

The remote-controlled pressure control adjusts the pump in direction of minimum displacement V_{gmin} upon reaching the set required pressure.

The integrated pressure control valve is controlled by a pressure relief valve (not supplied) which is located separate from the pump.

The integrated pressure control valve is uniformly supplied with pressure from both sides in addition to the spring force (pressure balance in a state of equilibrium) until the required pressure of the separate pressure limiting valve is reached.

The required pressure lies between 50 and 350 bar.

When the required pressure is reached on the separate pressure limiting valve, it opens and the pressure on the spring side of the integrated pressure control valve is reduced to tank. The integrated pressure control valve switches (pressure balance no longer in a state of equilibrium) and the pump swivels in direction of minimum displacement V_{gmin} .

The differential pressure on the integrated pressure control valve is set to 25 bar as standard. The consumption of control oil is then approx. 2 L/min. Please specify in plain text if a different setting (range 14 to 50 bar) is required.

The following are recommended for use as separate pressure limiting valve:

DBD 6 (hydraulic) as per RE 25402

DBETR-SO 437 with damped piston (electric) as per RE 29166

The max. line length should not exceed 2 m.

Circuit diagram, hydraulic control with electrical proportional valve and remote-controlled pressure control

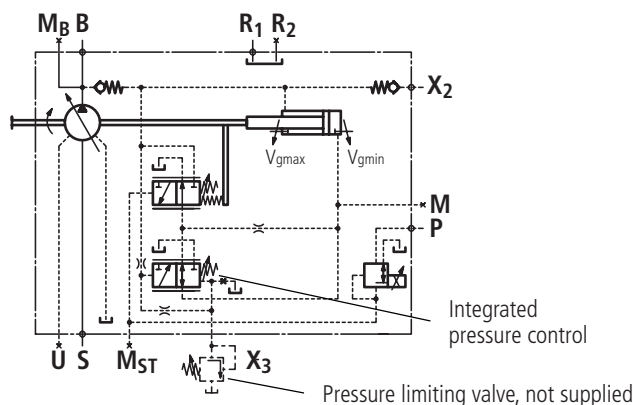

Characteristic

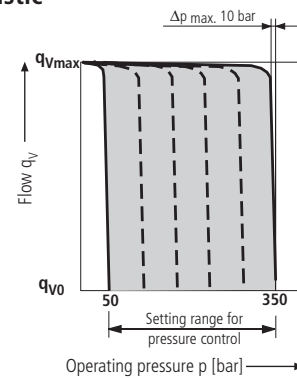

Unit dimensions

General dimensions on pages 7-9.

Clockwise rotation

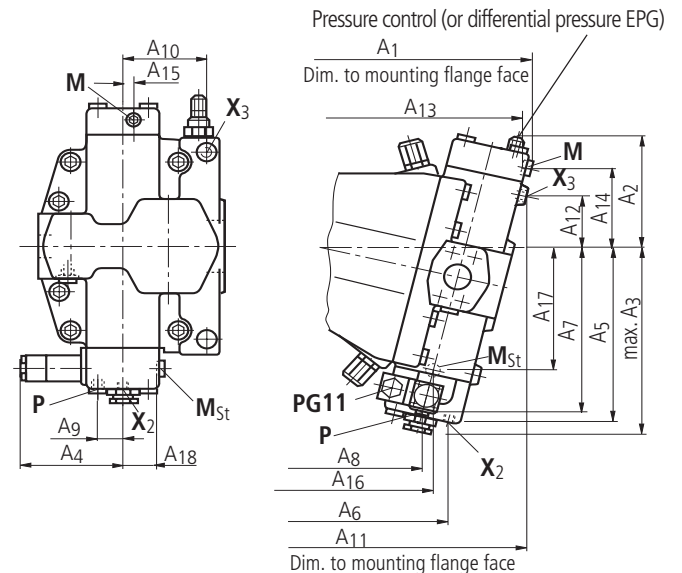

Anticlockwise rotation

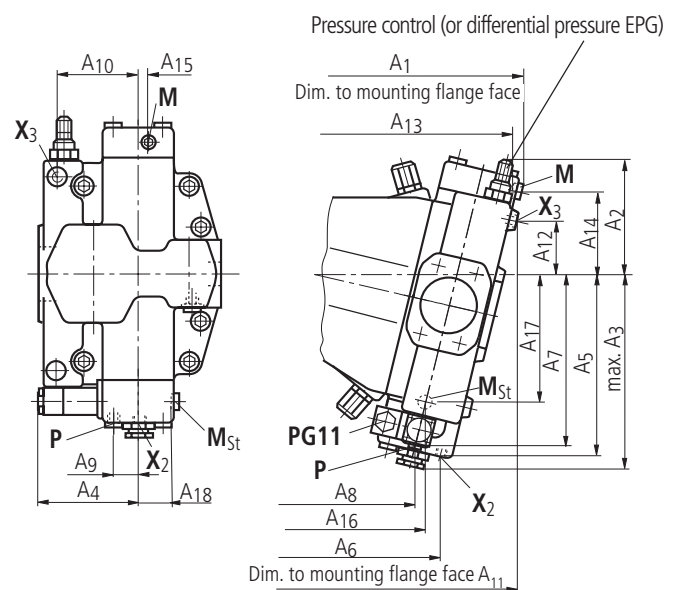

Table of dimensions and ports, see page 20.

V Visual swivel angle indication / E Electrical swivel angle indication

Before finalising your design, please request certified assembly drawing. Subject to change without notice.

V Visual swivel angle indication

The swivel position is indicated by a pin at the side of the port plate (cap nut must be removed).

The protruding length of the pin varies in accordance with the position of the control cam.

The pump is at **zero** when it is **flush with the port plate**.

The **length of the pin is approx. 8 mm** when swivelled to maximum V_{gmax} .

Circuit diagram, for example LRD – initial setting V_{gmax}

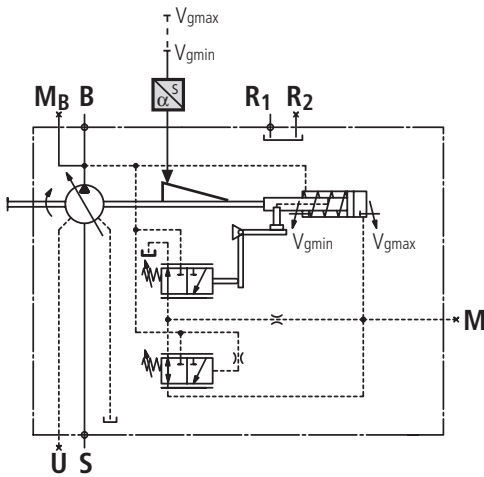

E Electrical swivel angle indication

The pump position is indicated via an inductive position transducer in this case.

The transducer transforms displacement of the control device into an electrical signal via which the swivel position can be fed to an amplifier card, for example.

Inductive position transducer type IW9 – 03 – 01

Circuit diagram, for example EPD – initial setting V_{gmin}

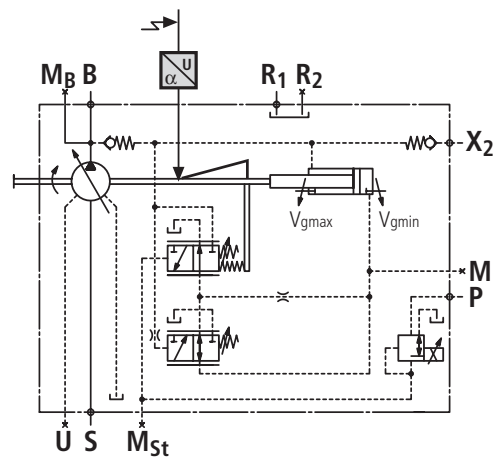

Unit dimensions

General dimensions on pages 7-10.

Visual indication V

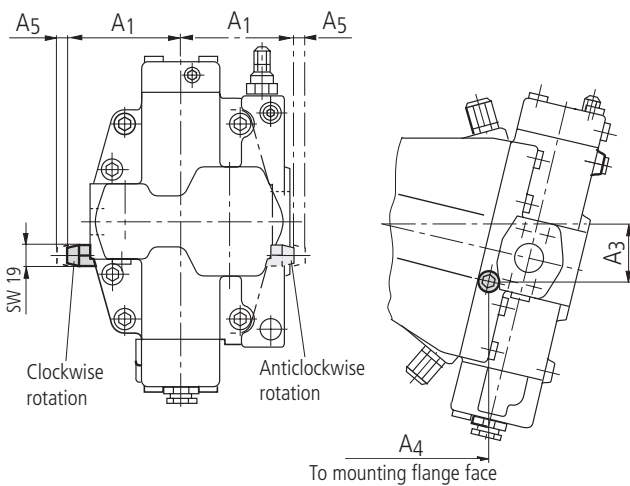

Unit dimensions

General dimensions on pages 7-10.

Electrical indication E

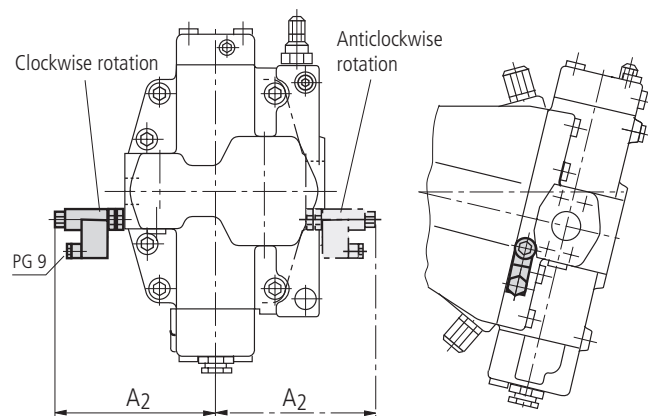

Unit dimensions

Size	A ₁	A ₂	A ₃	A ₄	A ₅ *
250	136.5	182	73	238	11
355	159.5	205	84	266	11
500	172.5	218	89	309	11
1000	208.5	254	114	402	11

* Value for removal of the cap nut

Preferred types

Preferred types (shorter delivery periods), please specify type and Ident number when ordering

Type	Ident No.
A7V O 250 DR/63R-VPB02	934705
A7V O 250 LRD/63R-VPB02	940153

Notes

Brueninghaus Hydromatik GmbH
Plant Horb
An den Kelterwiesen 14
72160 Horb, Germany
Tel. +49 (0) 74 51-92-0
Fax +49 (0) 74 51-82 21
info.brm@boschrexroth.de
www.boschrexroth.com/brm

© 2002 by Brueninghaus Hydromatik GmbH, 72160 Horb

All rights reserved. No part of this document may be reproduced or stored, processed, duplicated or circulated using electronic systems, in any form or by any means, without the prior written authorization of Brueninghaus Hydromatik GmbH. Violations shall give rise to claims for damages.

The data specified above only serve to describe the product. They do not indicate any specific condition or suitability for a certain application. The information provided does not release the user from the obligation of own judgement and verification. It must be remembered that our products are subject to natural wear and ageing.