

RE 51 062/11.02

Replaces: 03.00

**Pump motor assembly
Type ABAPG**

With pump types: • A10VSO

• PV7

• PGF3

• PGH

Electric motor frame sizes 112 to 280



H/AD 5884/97

Pump motor assembly type ABAPG-...

Overview of contents

Contents	Page
Features	1
Ordering details	2
Pump motor assembly design	2
Technical data	3 and 4
Circuits	5 to 7
Selection tables	8 to 12
Unit dimensions	13 to 17
Pipe connections	18
Installation guidelines	18
Commissioning guidelines	19
Engineering guidelines	19

Features

Within the pump motor assembly electrical energy is converted into hydraulic energy.

They are designed for use as open circuit hydrostatic drives.

- Electric motor, foot and flange mounting, frame type B35
- Pump is mounted onto the electric motor using a pump mounting bracket and drive coupling
- Can be fitted onto a reservoir, base frame or be separately mounted
- Low operating noise
- Numerous areas of application
- Accessibly and maintenance friendly design
- Optional with fixed or variable displacement pumps
- Combination pumps for multiple circuits is possible



© 2002
by Bosch Rexroth AG, Industrial Hydraulics, D-97813 Lohr am Main

All rights reserved. No part of this document may be reproduced or stored, processed, duplicated or circulated using electronic systems, in any form or by means, without the prior written authorisation of Bosch Rexroth AG. In the event of contravention of the above provisions, the contravening party is obliged to pay compensation.

This document was prepared with the greatest of care, and all statements have been examined for correctness. This document is subject to alterations for reason of the continuing further developments of products. No liability can be accepted for any incorrect or incomplete statements.

Ordering details

ABAPG							
Type To Rexroth standard RN 116.02							
Pump type Pump selection to preferred types: Axial piston pump A10VSO to RE 92 711 (NS 28 to NS 140) and RE 92 712 (NS 18) Variable vane pump to RE 10 515 Internal gear pump to RE 10 213 Internal gear pump to RE 10 223 Internal gear pump to RE 10 223		= A10VSO					
Pump nominal size See pages 8 to 12 For the PV7 pump, state pump size		= PV7/					
Control and adjustment devices Pressure and flow controller for A10VSO Power controller for A10VSO Pressure controller for PV7/25 and PV7/40 Pressure controller for PV7/63 and PV7/100		= DFR1 ¹⁾					
		= DFLR ¹⁾					
		= C0-16 ²⁾					
		= C0-14 ²⁾					

Variations	
A =	For basic version
B =	With pump safety block
SE =	Rigid pump mounting bracket, flexibly mounted
A =	Start-up assistance
B =	Pump safety block to RE 25 890 for pump type A10VSO
M =	Test point
F =	Pressure flanges for pumps with flange connections
R =	Suction pipe
Electric motor frame size See pages 8 to 12	

1) These order details are only required in conjunction with pump type A10VSO.

2) These order details are only required in conjunction with pump type PV7.

Further types on request !

Ordering example with axial piston pump:

ABAPG-A10VSO45DFR1/160M-4-B0/SEABFR-B

Ordering example with variable vane pump:

ABAPG-PV7/25C0-16/132S-4-B0/SE-A

Pump motor assembly design

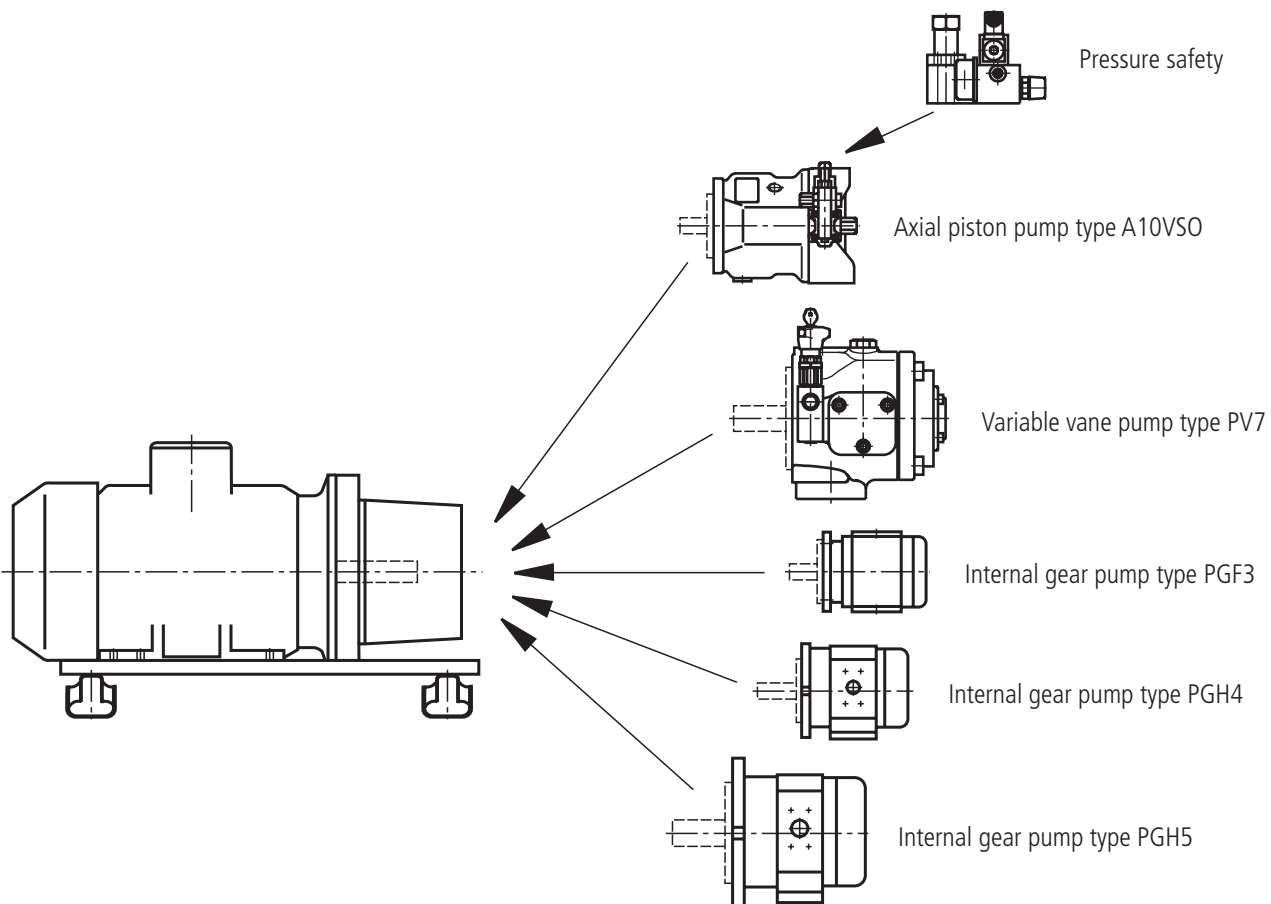

Technical data (for applications outside these parameters, please consult us!)

Pipe connections	Connection threads to ISO 1179 (inch), ISO 9974 (metric) or pipe threads to ISO 8434, part 1 (cutting ring fittings), part 4 (weld nipples) light or heavy series, flanges to ISO 6162 (SAE interface) or rectangular			
Pressure fluid	Mineral oil HLP to DIN 51 524; part 2 e. g. with an operating temperature of 50 °C ISO VG46 DIN 51 519 (other pressure fluids on request !) <ul style="list-style-type: none"> • Please take our specifications in catalogue sheet RE 07 075 into account. • Different types of oil must not be mixed, as sedimentation and a reduction in lubrication could result. • Dependent on the operating conditions the oil has to be changed at regular intervals. 			
Pump type	A10VSO18 to catalogue sheet RE 92 712			
	A10VSO28-140 to catalogue sheet RE 92 711			
	PV7 to catalogue sheet RE 10 515			
	PGF3 to catalogue sheet RE 10 213			
	PGH to catalogue sheet RE 10 223			
Operating pressure, absolute with pump type:				
A10VSO	Inlet	$p_{\min-\max}$	bar	0.8 to 30
	Outlet	p_{nom}	bar	250
	Peak pressure	p_{\max}	bar	315
	Drain connection	p_{\max}	bar	2
PV7	Inlet	$p_{\min-\max}$	bar	0.8 to 2.5
	Outlet	p_{nom}	bar	Up to 160 (dependent on the frame size)
	Drain connection	p_{\max}	bar	2
PGF3	Inlet	$p_{\min-\max}$	bar	0.6 to 3
	Outlet	p_{nom}	bar	210
	Peak pressure	p_{\max}	bar	250
PGH	Inlet	$p_{\min-\max}$	bar	0.8 to 2.0
	Outlet	p_{nom}	bar	250
	Peak pressure	p_{\max}	bar	315
Pressure fluid temperature range for pump type:				
A10VSO	\varnothing		°C	- 25 to +90
PV7	\varnothing		°C	- 10 to +70
PGF3, PGH	\varnothing		°C	- 20 to +100
The optimum operating temperature for the pump motor assembly when using mineral oil HLP to DIN 51 524 lies between 40 °C and 50 °C. The operating temperature for continuous operation should not exceed 70 °C. For start-up at low temperatures for heaters can be fitted. For cooling purposes either an oil/water or oil/air cooler can be fitted.				
Cleanliness class to ISO code	Maximum permissible degree of contamination of the pressure fluid is to ISO 4406 (C) dependent on the pump type fitted ¹⁾			

¹⁾ The cleanliness class stated for the components must be adhered too in hydraulic systems. Effective filtration prevents faults from occurring and at the same time increases the component service life. For the selection of filters see catalogue sheets RE 50 070, RE 50 076 and RE 50 081.

Technical data (for applications outside these parameters, please consult us!)

Pressure safety				For pumps that have a flange connection to ISO 6162 (A10VSO; PGF3; PGH); Pump safety block type DBA.../DBAW to RE 25 890
Viscosity range for pump type:				
	A10VSO	ϑ	mm ² /s	16 to 36 optimum 10 to 1000 briefly (see RE 92 711 or RE 92 712)
	PV7	ϑ	mm ² /s	16 to 160 at operating temperature (see RE 10 515)
	PGF3, PGH	ϑ	mm ² /s	10 to 300, the permissible start viscosity is 2000 mm ² /s (see RE 10 213 and RE 10 223)
Electric motor	Motor type			AC asynchronous motor
	No. of poles			4
	Voltage	U	V	230 / 400 at 50 Hz; 400 / 690 at 50 Hz
	to IEC 38		V	460 at 60 Hz
	RPM	n	min ⁻¹	1500 at 50 Hz
			min ⁻¹	1800 at 60 Hz
	Protection		IP	55
	Direction of rotation			
Installation				Horizontal
Surface finish				Preferably undercoat epoxy resin RAL 5009 (RN 123.01) Optionally coating based on one component alkyd resin or two component polyurethen. Diverse colour tones to RAL colour chart.



Note:

For assembly, commissioning and maintenance of hydraulic systems, please take the specifications stated within catalogue sheet RE 07 900 into account.

The pump motor assembly has been designed and manufactured in accordance with the harmonised EN standards/specifications.

Circuits

Axial piston pump (basic version)

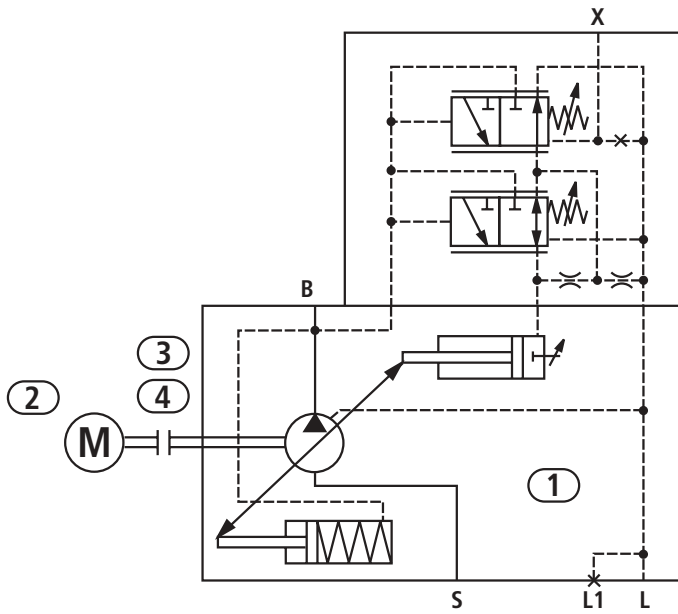

- 1 Axial piston pump A10VSO
- 2 Electric motor
- 3 Pump mounting bracket
- 4 Coupling

Axial piston pump with pressure safety and start-up assistance

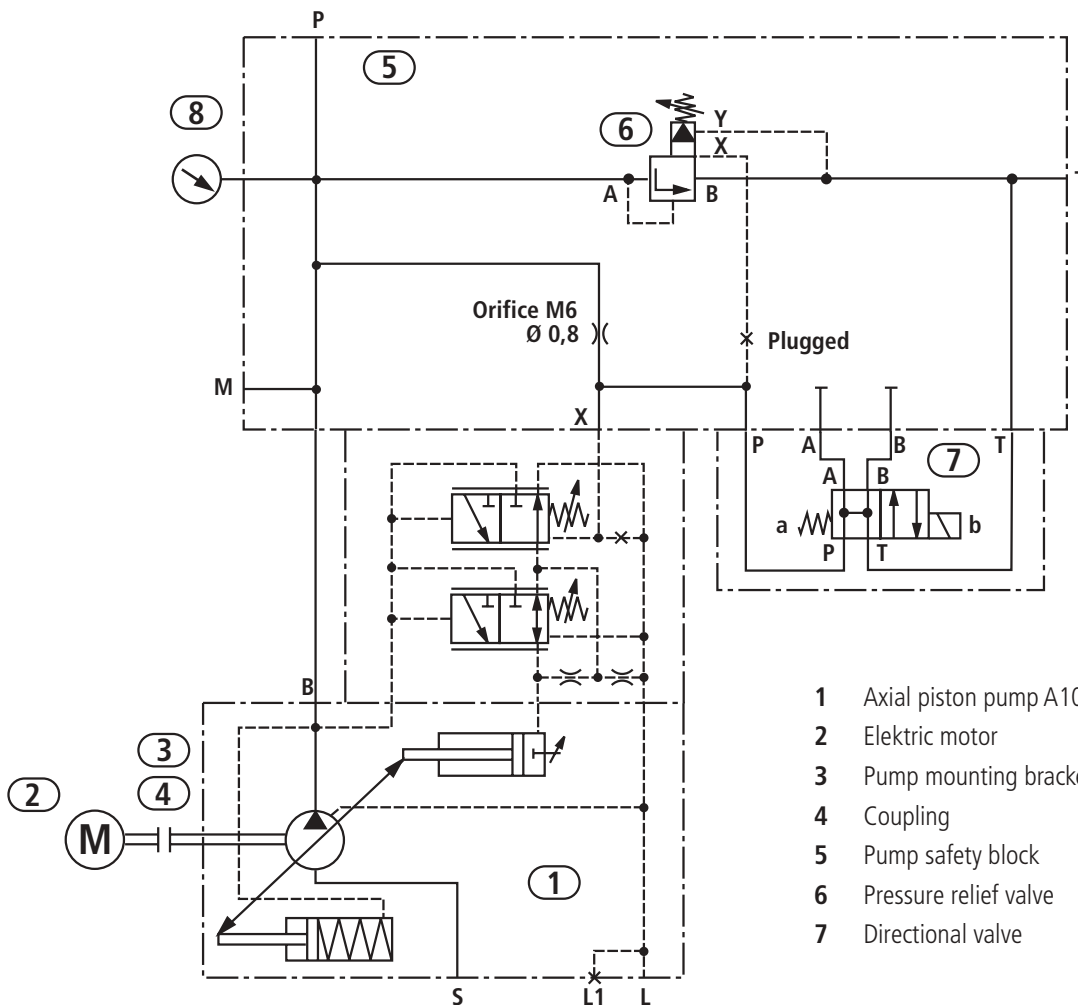

- 1 Axial piston pump A10VSO
- 2 Elektric motor
- 3 Pump mounting bracket
- 4 Coupling
- 5 Pump safety block
- 6 Pressure relief valve
- 7 Directional valve

Circuits

Axial piston pump with pressure, flow and power controller (basic version)

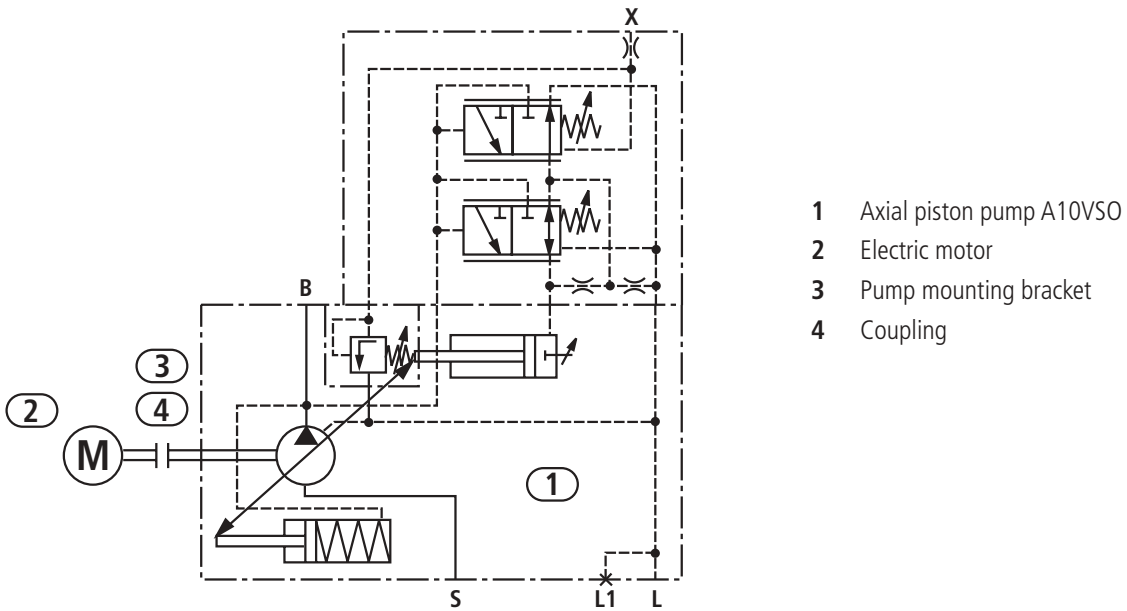

Axial piston pump with pressure, flow and power controller with pressure safety and start-up assistance

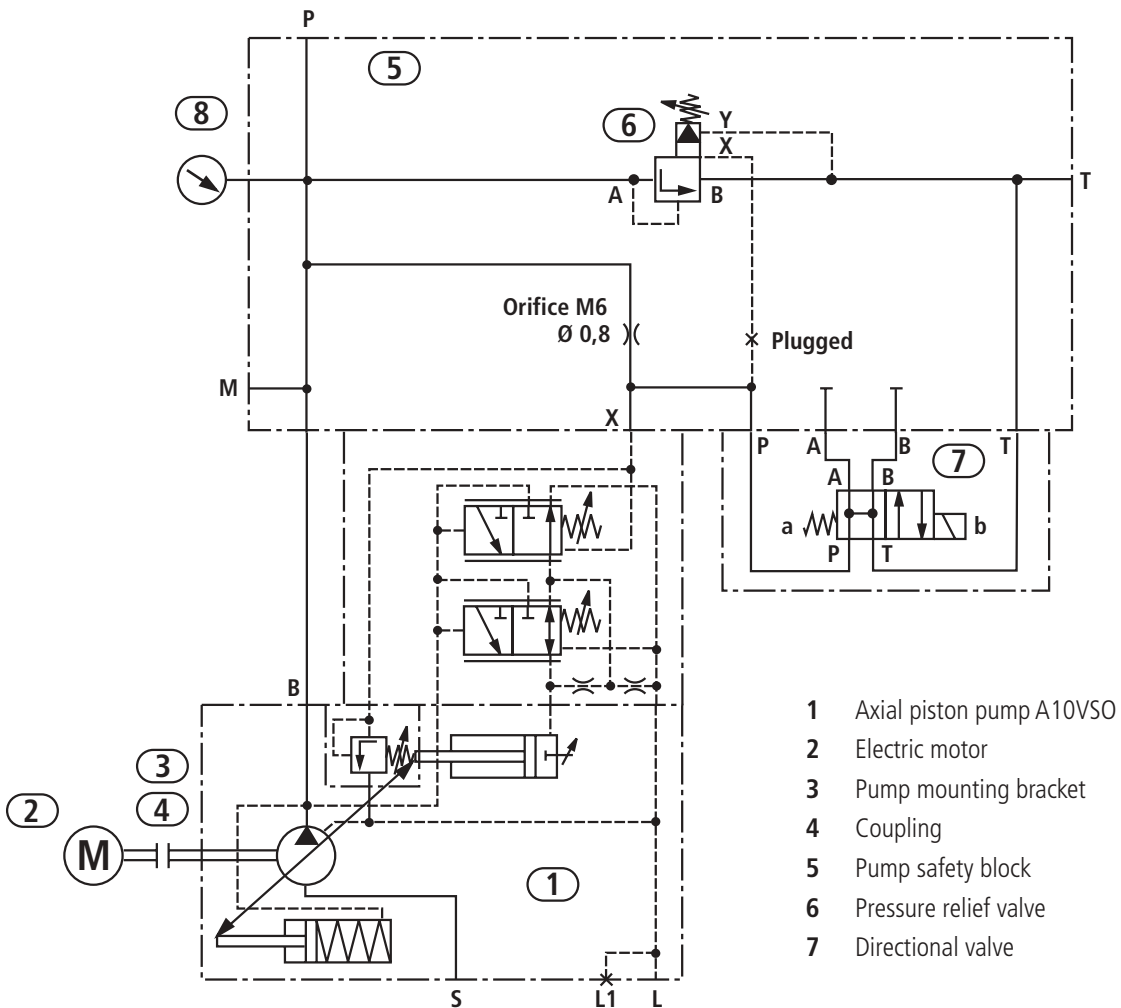

Performance characteristics – axial piston pump with power controller measured at $n = 1450 \text{ min}^{-1}$ (factory pre-set)

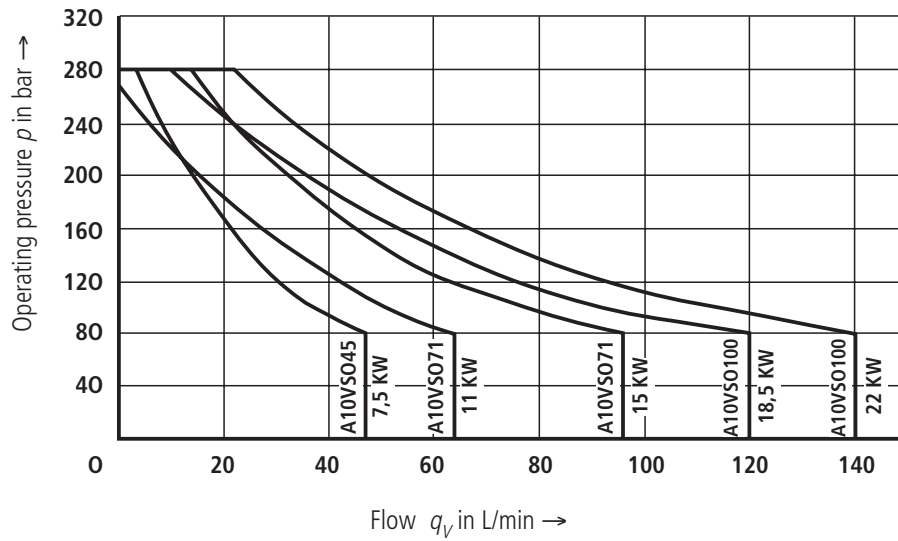

For engineering purposes please use the performance characteristics shown in RE 92 711.

Variable vane pump

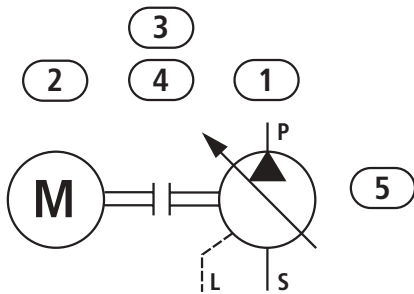

- 1 Variable vane pump PV7
- 2 Electric motor
- 3 Pump mounting bracket
- 4 Coupling
- 5 Test point

Internal gear pump

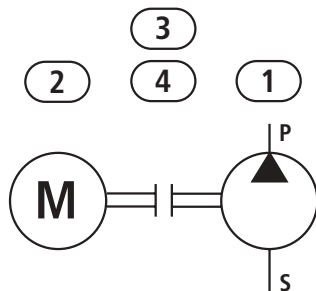

- 1 Internal gear pumps PGF3, PGH4, PGH5
- 2 Electric motor
- 3 Pump mounting bracket
- 4 Coupling

Selection table for preferred types ABAPG-A10VSO...DFR1/.../SE...

Frequency	50 Hz 1500 min ⁻¹	60 Hz 1800 min ⁻¹		50 Hz 1500 min ⁻¹	60 Hz 1800 min ⁻¹	Electric motor frame size	Basic version ¹⁾ Material No.	...SEABFR... ²⁾ Material No.	Total weight in kg
Pump	$q_{V \max}$ in L/min		p_{\max} in bar	Power in kW					
A10VSO18	26	31	90	4	4.8	112M-4-B0	R900959278	R900959273	61
			110	5.5	6.6	132S-4-B0	R900936867	R900959274	78
			138	7.5	9	132M-4-B1	R900914569	R900959276	92
			203	11	13.2	160M-4-B0	R900914636	R900951204	123
A10VSO28	40	49	95	7.5	9	132M-4-B1	R900936868	R900968517	95
			132	11	13.2	160M-4-B0	R900914638	R900932784	126
			180	15	18	160L-4-B1	R900914637	R900932785	142
			222	18.5	22.2	180M-4-B0	R900914639	R900959277	223
A10VSO45	65	78	60	7.5	9	132M-4-B1	R900970460	R900976354	101
			81	11	13.2	160M-4-B0	R900914641	R900941708	132
			111	15	18	160L-4-B1	R900914640	R900932786	148
			137	18.5	22.2	180M-4-B0	R900914643	R900932787	229
			162	22	26.4	180L-4-B1	R900914642	R900932788	244
			222	30	36	200L-4-B0	R900914644	R900960756	319
A10VSO71	100	124	72	15	18	160L-4-B1	R900914645	R900960757	160
			89	18.5	22.2	180M-4-B0	R900914647	R900960758	241
			106	22	26.4	180L-4-B1	R900914646	R900932789	256
			144	30	36	200L-4-B0	R900914648	R900932790	331
			178	37	44.4	225S-4-B0	R900914650	R900932791	402
			216	45	54	225M-4-B1	R900914649	R900960759	432
A10VSO100	145	174	61	18.5	22.2	180M-4-B0	R900914613	R900960760	253
			73	22	26.4	180L-4-B1	R900914612	R900960761	268
			99	30	36	200L-4-B0	R900914614	R900932792	343
			122	37	44.4	225S-4-B0	R900914617	R900932793	414
			149	45	54	225M-4-B1	R900914616	R900932794	445
			182	55	66	250M-4-B0	R900914618	R900946940	578
A10VSO140	200	244	72	30	36	200L-4-B0	R900914621	R900960762	358
			89	37	44.4	225S-4-B0	R900914630	R900960763	429
			108	45	54	225M-4-B1	R900914622	R900960764	460
			132	55	66	250M-4-B0	R900914631	R900960765	593
			180	75	90	280S-4-B0	R900914632	R900960766	795

Selection table for preferred types ABAPG-A10VSO...DFLR/.../SE...

Frequency	50 Hz	60 Hz	Electric motor frame size	Basic version ¹⁾ Material No.	...SEABFR... ²⁾ Material No.	Total weight in kg
Pump	Power in kW					
A10VSO45	7.5	9	132M-4-B1	R900972179	R900976632	101
A10VSO71	11	13.2	160M-4-B0	R900972180	R900976633	144
A10VSO71	15	18	160L-4-B1	R900972181	R900976634	160
A10VSO100	18.5	21.6	180M-4-B0	R900972182	R900976635	253
A10VSO100	22	26.4	180L-4-B1	R900972183	R900976641	268

¹⁾ The basic version comprises of:

- Pump
- Electric motor
- Pump mounting bracket
- Coupling
- Pads
- Anti-vibration mounts

²⁾ The version .../...SEABFR... has in addition:

- AB** = Start-up assistance to AB-E 01-10.01 and pump safety block to AB-E 42-42
- F** = Pressure flange with a connection for a pipe or hose, heavy series to Rexroth standard AB-E 22-14
- R** = Suction pipe to Rexroth standard AB-E 23-03

Selection table ABAPG-PV7.../.../SE...

Frequency	50 Hz 1500 min ⁻¹	60 Hz 1800 min ⁻¹		50 Hz 1500 min ⁻¹	60 Hz 1800 min ⁻¹	Electric motor frame size	Basic version ¹⁾ Material No.	...MR... ²⁾ Material No.	...MFR... ³⁾ Material No.	Total weight in kg
Pump	$q_{V \max}$ in L/min		p_{\max} in bar	Power in kW						
PV7/16-20	29	3	90	5.5	6.6	132S-4-B0	R900932475	–	–	83
			125	7.5	9	132M-4-B1	R900964783	–	–	97
PV7/25-30	43	52	61	5.5	6.6	132S-4-B0	R900914671	R900901102	–	87
			84	7.5	9	132M-4-B1	R900914670	–	–	101
PV7/40-45	66	78	40	5.5	6.6	132S-4-B0	R900914675	R900901103	–	96
			55	7.5	9	132M-4-B1	R900914674	R900901104	–	110
			80	11	13.2	160M-4-B0	R900914678	R900901106	–	141
			109	15	18	160L-4-B1	R900914676	R900901105	–	157
PV7/63-71	108	124	24	5,5	6,6	132S-4-B0	R900914680	–	R900901108	103
			33	7,5	9	132M-4-B1	R900914679	–	R900901144	117
			49	11	13.2	160M-4-B0	R900914683	–	R900901146	148
			67	15	18	160L-4-B1	R900914681	–	R900901145	164
			82	18.5	22.2	180M-4-B0	R900914685	–	R900901149	245
			98	22	26.4	180L-4-B1	R900914684	–	R900901150	260
PV7/100-118	171	205	31	11	13.2	160M-4-B0	R900914657	–	R900901151	167
			42	15	18	160L-4-B1	R900914656	–	R900901153	183
			52	18.5	22.2	180M-4-B0	R900914659	–	R900901154	264
			62	22	26.4	180L-4-B1	R900914658	–	R900901155	279
			84	30	36	200L-4-B0	R900914660	–	R900901156	344

1) The basic version comprises of:

- Pump
- Electric motor
- Pump mounting bracket
- Coupling
- Pads
- Anti-vibration mounts

2) The version .../...**MR**... has in addition:

- M** = Test point to Rexroth standard AB-E 20–11
- R** = Suction pipe to Rexroth standard AB-E 23–03

3) The version .../...**MFR**... has in addition:

- M** = Test point to Rexroth standard AB-E 20–11
- F** = Pressure flange with a connection for a pipe or hose, heavy series to Rexroth standard AB-E 22–14
- R** = Suction pipe to Rexroth standard AB-E 23–03

Selection table for preferred types ABAPG-PGF3.../.../SE...

Frequency	50 Hz 1500 min ⁻¹	60 Hz 1800 min ⁻¹		50 Hz 1500 min ⁻¹	60 Hz 1800 min ⁻¹	Electric motor	Basic version ¹⁾	Total weight in kg
Pump	$q_{V \max}$ in L/min		p_{\max} in bar	Power in kW		frame size	Material No.	
GF3-20	29	35	91	5.5	6.6	132S-4-B0	R900914571	70
			124	7.5	9	132M-4-B1	R900914713	84
			182	11	13.2	160M-4-B0	R900914714	115
GF3-22	32	38	83	5.5	6.6	132S-4-B0	R900914717	70
			113	7.5	9	132M-4-B1	R900914720	84
			166	11	13.2	160M-4-B0	R900914722	115
			226	15	18	160L-4-B1	R900914723	131
GF3-25	36	44	73	5.5	6.6	132S-4-B0	R900914724	70
			99	7.5	9	132M-4-B1	R900914726	84
			146	11	13.2	160M-4-B0	R900914728	115
			199	15	18	160L-4-B1	R900914730	131
GF3-32	46	56	57	5.5	6.6	132S-4-B0	R900914733	71
			78	7.5	9	132M-4-B1	R900914734	85
			114	11	13.2	160M-4-B0	R900914737	116
			155	15	18	160L-4-B1	R900914738	132
			191	18.5	22.2	180M-4-B0	R900914739	212
GF3-40	58	70	46	5.5	6.6	132S-4-B0	R900914741	71
			62	7.5	9	132M-4-B1	R900914743	85
			91	11	13.2	160M-4-B0	R900914744	116
			124	15	18	160L-4-B1	R900914747	132
			153	18.5	22.2	180M-4-B0	R900914748	212

¹⁾ The basic version comprises of:

- Pump
- Electric motor
- Pump mounting bracket
- Coupling
- Pads
- Anti-vibration mounts

Selection table for preferred types ABAPG-PGH4.../.../SE...

Frequency	50 Hz 1500 min ⁻¹	60 Hz 1800 min ⁻¹		50 Hz 1500 min ⁻¹	60 Hz 1800 min ⁻¹	Electric motor	Basic version ¹⁾	Total weight in kg
Pump	$q_{V \max}$ in L/min		p_{\max} in bar	Power in kW		frame size	Material No.	
PGH4-20	29	35	182	11	13.2	160M-4-B0	R900914752	126
			248	15	18	160L-4-B1	R900914753	142
PGH4-25	36	44	146	11	13.2	160M-4-B0	R900914754	126
			199	15	18	160L-4-B1	R900914755	142
			245	18.5	22.2	180M-4-B0	R900914756	223
PGH4-32	46	56	114	11	13.2	160M-4-B0	R900914757	127
			155	15	18	160L-4-B1	R900914758	143
			191	18.5	22.2	180M-4-B0	R900914759	224
			228	22	26.4	180L-4-B1	R900914760	249
PGH4-40	58	70	91	11	13.2	160M-4-B0	R900914761	127
			124	15	18	160L-4-B1	R900914762	143
			153	18.5	22.2	180M-4-B0	R900914764	224
			182	22	26.4	180L-4-B1	R900914766	249
			248	30	36	200L-4-B0	R900914767	313
PGH4-50	73	87	73	11	13.2	160M-4-B0	R900914770	128
			99	15	18	160L-4-B1	R900914771	144
			122	18.5	22.2	180M-4-B0	R900914772	225
			146	22	26.4	180L-4-B1	R900914773	250
			199	30	36	200L-4-B0	R900914774	314
			245	37	44.4	225S-4-B0	R900914775	385

¹⁾ The basic version comprises of:

- Pump
- Electric motor
- Pump mounting bracket
- Coupling
- Pads
- Anti-vibration mounts

Selection table for preferred types ABAPG-PGH5.../.../SE...

Frequency	50 Hz 1500 min ⁻¹	60 Hz 1800 min ⁻¹		50 Hz 1500 min ⁻¹	60 Hz 1800 min ⁻¹	Electric motor	Basic version ¹⁾	Total weight in kg
Pump	$q_{V \max}$ in L/min		p_{\max} in bar	Power in kW		frame size	Material No.	
PGH5-63	91	110	58	11	13.2	160M-4-B0	R900914776	150
			79	15	18	160L-4-B1	R900914777	166
			97	18.5	22.2	180M-4-B0	R900914778	247
			116	22	26.4	180L-4-B1	R900914780	262
			158	30	36	200L-4-B0	R900914781	337
			194	37	44.4	225S-4-B0	R900914782	408
			236	45	54	225M-4-B1	R900914784	438
PGH5-80	116	139	62	15	18	160L-4-B1	R900914785	168
			77	18.5	22.2	180M-4-B0	R900914786	249
			91	22	26.4	180L-4-B1	R900914788	264
			124	30	36	200L-4-B0	R900914789	339
			153	37	44.4	225S-4-B0	R900914790	410
			186	45	54	225M-4-B1	R900914792	440
			228	55	66	250M-4-B0	R900914793	574
PGH5-100	145	174	61	18.5	22.2	180M-4-B0	R900914795	251
			73	22	26.4	180L-4-B1	R900914797	266
			99	30	36	200L-4-B0	R900914798	341
			122	37	44.4	225S-4-B0	R900914799	412
			149	45	54	225M-4-B1	R900914800	443
			182	55	66	250M-4-B0	R900914801	576
			248	75	90	280S-4-B0	R900914802	778
PGH5-125	181	218	58	22	26.4	180L-4-B1	R900914803	255
			79	30	36	200L-4-B0	R900914804	345
			98	37	44.4	225S-4-B0	R900914805	416
			119	45	54	225M-4-B1	R900914807	447
			146	55	66	250M-4-B0	R900914808	580
			199	75	90	280S-4-B0	R900914809	785

¹⁾ The basic version comprises of:

- Pump
- Electric motor
- Pump mounting bracket
- Coupling
- Pads
- Anti-vibration mounts

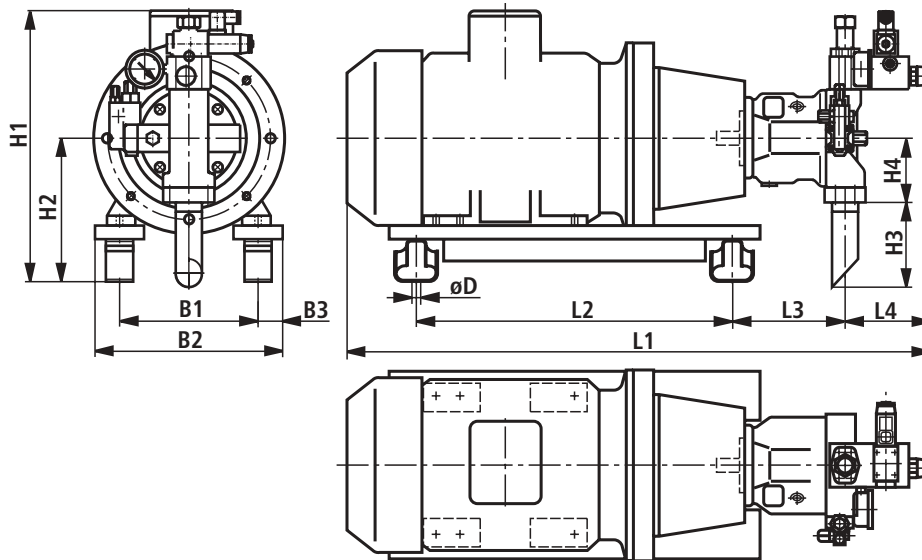

Pump	Electric motor frame size	Dimensions											
		B1	B2	B3	øD	H1	H2	H3	H4	L1	L2	L3	L4
A10VSO18	112M-4-B0	190	260	35	11	380	192	550	63	680	350	159	165
	132S-4-B0	216	300	42	13.5	430	235	550	63	830	450	143	165
	132M-4-B1	216	300	42	13.5	430	235	550	63	830	450	143	165
	160M-4-B0	254	350	48	13.5	496	263	550	63	940	580	151	165
A10VSO28	132M-4-B1	216	300	42	13.5	430	235	550	80	860	450	173	165
	160M-4-B0	254	350	48	13.5	496	263	600	80	950	580	170	165
	160L-4-B1	254	350	48	13.5	496	263	600	80	950	580	170	165
	180M-4-A0	279	369	45	13.5	542	283	600	80	1075	620	184	165
A10VSO45	132M-4-B1	216	300	42	13.5	430	235	550	90	880	450	193	163
	160M-4-B0	254	350	48	13.5	496	263	650	90	965	580	190	163
	160L-4-B1	254	350	48	13.5	496	263	650	90	965	580	190	163
	180M-4-B0	279	369	45	13.5	542	283	650	90	1150	620	204	163
	180L-4-B1	279	369	45	13.5	542	283	650	90	1150	620	204	163
	200L-4-B0	318	418	50	17.5	644	338	650	90	1160	700	171	163
A10VSO71	160L-4-B1	254	350	48	13.5	496	263	700	104	1010	580	239	168
	180M-4-B0	279	369	45	13.5	542	283	700	104	1140	620	237	168
	180L-4-B1	279	369	45	13.5	542	283	700	104	1140	620	237	168
	200L-4-B0	318	418	50	17.5	644	338	700	104	1195	700	204	168
	225S-4-B0	356	456	50	17.5	718	363	700	104	1255	800	160	168
	225M-4-B1	356	456	50	17.5	718	363	700	104	1255	800	160	168
A10VSO100	180M-4-B0	279	369	45	13.5	542	313	750	100	1200	620	295	157
	180L-4-B1	279	369	45	13.5	542	313	750	100	1200	620	295	157
	200L-4-B0	318	418	50	17.5	644	338	750	100	1275	700	286	157
	225S-4-B0	356	456	50	17.5	718	363	750	100	1310	800	218	157
	225M-4-B1	356	456	50	17.5	718	363	750	100	1310	800	218	157
	250M-4-B0	616	676	72	23	798	368	750	100	1420	850	250	157
	280S-4-B1	667	727	70	23	853	398	750	110	1535	900	310	157
A10VSO140	200L-4-B0	318	418	50	17.5	656	338	750	110	1290	700	286	157
	225S-4-B0	356	456	50	17.5	718	363	750	110	1360	800	246	157
	225M-4-B1	356	456	50	17.5	718	363	750	110	1360	800	246	157
	250M-4-B1	616	676	72	23	798	368	750	110	1450	850	267	157
	280S-4-B1	667	727	70	23	853	398	750	110	1535	900	310	157

Note: The suction pipe length H3 has to be cut to the relevant length when the pump motor assembly is fitted into a reservoir. Take the installation guidelines stated on page 18 into account.

Pump type	Pipe connections				
	Press. connection P ¹⁾	Press. flange for hose	Suction connection S	Suction pipe Ø	Drain connection L
A10VSO18	SAE 3/4" (STD)	25S	SAE 1"	35	M16 x 1.5
A10VSO28	SAE 3/4" (STD)	25S	SAE 1 1/4"	42	M18 x 1.5
A10VSO45	SAE 1" (STD)	30S	SAE 1 1/2"	48.3	M22 x 1.5
A10VSO71	SAE 1" (STD)	30S	SAE 2"	60.3	M22 x 1.5
A10VSO100	SAE 1 1/4" (HD)	38S	SAE 2 1/2"	76.1	M27 x 2
A10VSO140	SAE 1 1/4" (HD)	38S	SAE 2 1/2"	76.1	M27 x 2

¹⁾ STD = Standard pressure series, 3000 PSI; HD = High pressure series, 6000 PSI

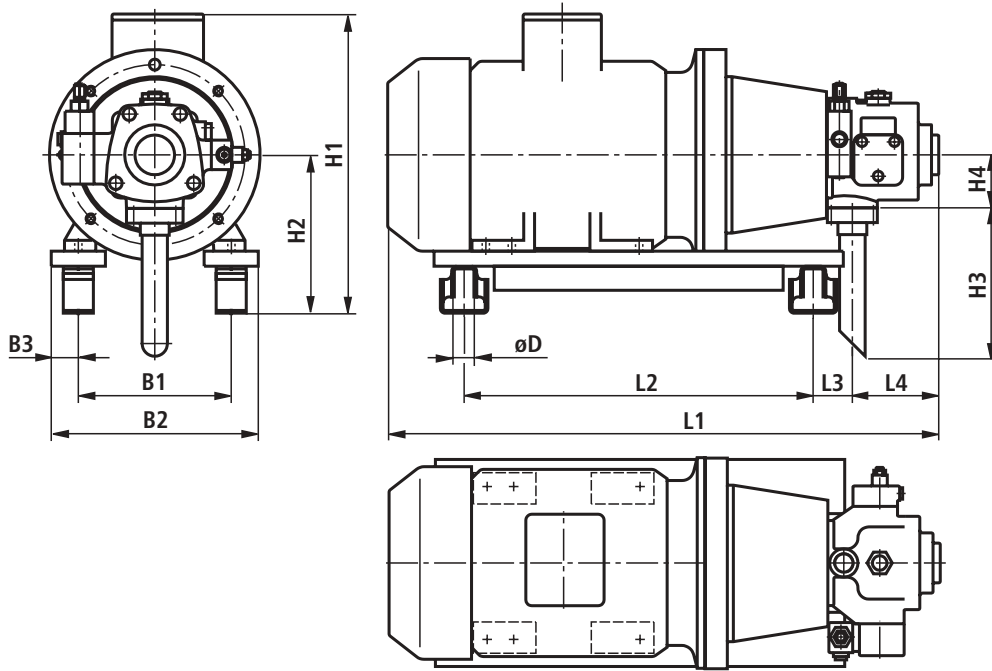

Pump	Electric motor frame size	Dimensions											
		B1	B2	B3	øD	H1	H2	H3	H4	L1	L2	L3	L4
PV7/25-30	132S-4-B0	216	300	42	13.5	430	235	550	92	745	450	47	139
	132M-4-B1	216	300	42	13.5	430	235	550	92	745	450	47	139
PV7/40-45	132S-4-B0	216	307.8	49.8	13.5	430	235	650	89	768	450	65	144
	132M4-B1	216	307.8	49.8	13.5	430	235	650	89	768	450	65	144
	160M-4-B0	254	350	48	13.5	496	263	650	89	872	580	65	144
	160L-4-B1	254	350	48	13.5	496	263	650	89	872	580	65	144
PV7/63-71	132S-4-B0	216	313.7	55.7	13.5	430	235	700	105	792	450	73	160
	132M-4-B1	216	313.7	55.7	13.5	430	235	700	105	792	450	73	160
	160M-4-B0	254	350	48	13.5	496	263	700	105	896	580	73	160
	160L-4-B1	254	350	48	13.5	496	263	700	105	896	580	73	160
	180M-4-B0	279	369	45	13.5	542	283	700	105	1025	620	73	160
	180L-4-B1	279	369	45	13.5	542	283	700	105	1025	620	73	160
PV7/100-118	160M-4-B0	254	366.7	64.7	13.5	496	263	750	126	951	580	106	182
	160L-4-B1	254	366.7	64.7	13.5	496	263	750	126	951	580	106	182
	180M-4-B0	279	376.2	52.2	13.5	542	283	750	126	1080	620	104	182
	180L-4-B1	279	376.2	52.2	13.5	542	283	750	126	1080	620	104	182
	200L-4-B0	318	418	50	17.5	644	338	750	126	1135	700	71	182

Note: The suction pipe length H3 has to be cut to the relevant length when the pump motor assembly is fitted onto a reservoir. Take the installation guidelines stated on page 18 into account.

Pump type	Pipe connections				
	Press. connection P ¹⁾	Pressure flange for hose	Suction connection S	Suction pipe Ø	Drain connection L
PV7/25-C016	G1	—	G 1 1/2	48.3	G 3/8
PV7/40-C016	G1	—	SAE 1 1/2"	48.3	G 1/2
PV7/63-C014	SAE 1 1/4" (STD)	38S	SAE 2"	60.3	G 1/2
PV7/100-C014	SAE 1 1/2" (STD)	38S	SAE 2 1/2"	76.1	G 3/4

¹⁾ STD = Standard pressure series, 3000 PSI

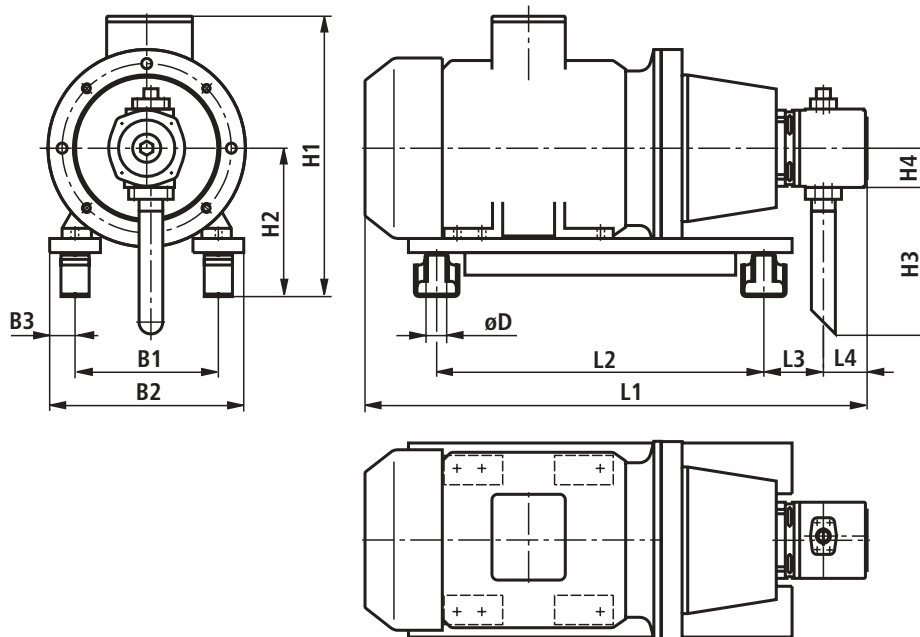

Pump	Electric motor frame size	Dimensions											
		B1	B2	B3	øD	H1	H2	H3	H4	L1	L2	L3	L4
PGF3-20	132S-4-B0	216	300	42	13.5	430	235	600	63	704	450	80	65
	132M-4-B1	216	300	42	13.5	430	235	600	63	704	450	80	65
	160M-4-B0	216	350	48	13.5	496	263	600	63	821	580	93	65
PGF3-22	132S-4-B0	216	300	42	13.5	430	235	600	63	706	450	81	66
	132M-4-B1	216	300	42	13.5	430	235	600	63	706	450	81	66
	160M-4-B0	254	350	48	13.5	496	263	600	63	823	580	94	66
	160L-4-B1	254	350	48	13.5	496	263	600	63	823	580	94	66
PGF3-25	132S-4-B0	216	300	42	13.5	430	235	600	63	710	450	83	68
	132M-4-B1	216	300	42	13.5	430	235	600	63	710	450	83	68
	160M-4-B0	254	350	48	13.5	496	263	600	63	827	580	96	68
	160L-4-B1	254	350	48	13.5	496	263	600	63	827	580	96	68
PGF3-32	132S-4-B0	216	300	42	13.5	430	235	600	63	719	450	87.5	72.5
	132M-4-B1	216	300	42	13.5	430	235	600	63	719	450	87.5	72.5
	160M-4-B0	254	350	48	13.5	496	263	600	63	836	580	100.5	72.5
	160L-4-B1	254	350	48	13.5	496	263	600	63	836	580	100.5	72.5
	180M-4-B0	279	350	35.5	13.5	542	283	600	63	965	620	98.5	72.5
PGF3-40	132S-4-B0	216	300	42	13.5	430	235	600	63	729	450	92.5	77.5
	132M-4-B1	216	300	42	13.5	430	235	600	63	729	450	92.5	77.5
	160M-4-B0	254	350	48	13.5	496	263	600	63	846	580	105.5	77.5
	160L-4-B1	254	350	48	13.5	496	263	600	63	846	580	105.5	77.5
	180M-4-B0	279	350	35.5	13.5	542	283	600	63	975	620	103.5	77.5

Note: The suction pipe length H3 has to be cut to the relevant length when the pump motor assembly is fitted onto a reservoir. Take the installation guidelines stated on page 18 into account.

Pump type	Pipe connections			
	Press. connection P ¹⁾	Pressure flange for hose	Suction connection S	Suction pipe Ø
PGF3-20	SAE 3/4" (STD)	25S	SAE 1 1/4"	42
PGF3-22	SAE 3/4" (STD)	25S	SAE 1 1/4"	42
PGF3-25	SAE 3/4" (STD)	25S	SAE 1 1/4"	42
PGF3-32	SAE 3/4" (STD)	25S	SAE 1 1/4"	42
PGF3-40	SAE 3/4" (STD)	25S	SAE 1 1/4"	42

¹⁾ STD = Standard pressure series, 3000 PSI

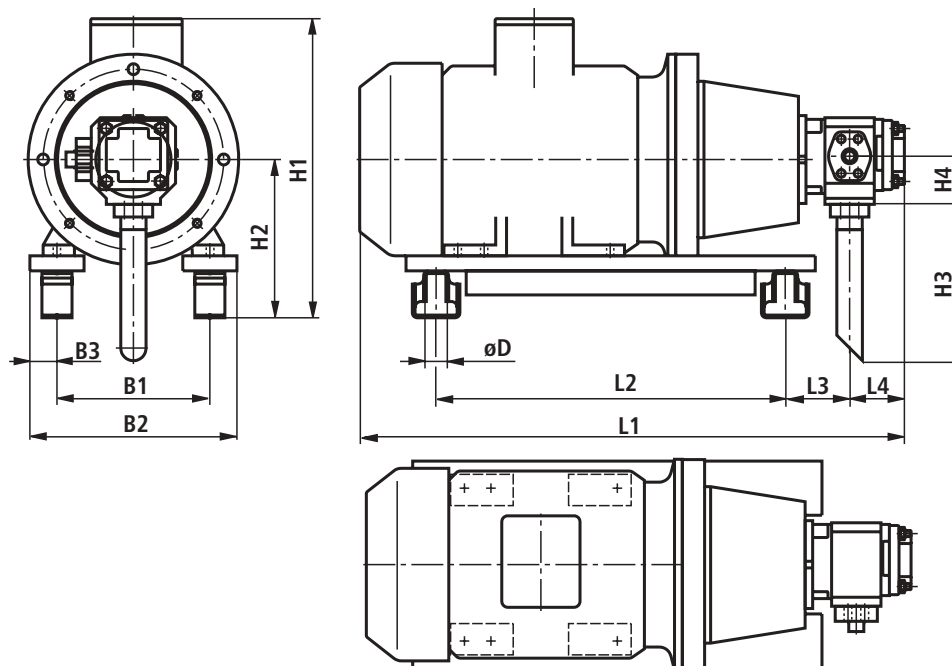

Pump	Electric motor frame size	Dimensions											
		B1	B2	B3	øD	H1	H2	H3	H4	L1	L2	L3	L4
PGH4-20	160M-4-B0	254	350	48	13.5	496	263	600	73	832	580	92.5	76.5
	160L-4-B1	254	350	48	13.5	496	263	600	73	832	580	92.5	76.5
PGH4-25	160M-4-B0	254	350	48	13.5	496	263	600	73	837	580	95	79
	160L-4-B1	254	350	48	13.5	496	263	600	73	837	580	95	79
	180M-4-B0	279	350	35.5	13.5	542	283	600	73	966	620	93	79
PGH4-32	160M-4-B0	254	350	48	13.5	496	263	650	73	844	580	98.5	82.5
	160L-4-B1	254	350	48	13.5	496	263	650	73	844	580	98.5	82.5
	180M-4-B0	279	350	35.5	13.5	542	283	650	73	973	620	96.5	82.5
	180L-4-B1	279	350	35.5	13.5	542	283	650	73	973	620	96.5	82.5
PGH4-40	160M-4-B0	254	350	48	13.5	496	263	650	73	851	580	102	86
	160L-4-B1	254	350	48	13.5	496	263	650	73	851	580	102	86
	180M-4-B0	279	350	35.5	13.5	542	283	650	73	980	620	100	86
	180L-4-B1	279	350	35.5	13.5	542	283	650	73	980	620	100	86
	200L-4-B0	318	400	41	17.5	644	338	650	73	1035	700	67	86
PGH4-50	160M-4-B0	254	350	48	13.5	496	263	650	73	861	580	107	91
	160L-4-B1	254	350	48	13.5	496	263	650	73	861	580	107	91
	180M-4-B0	279	350	35.5	13.5	542	283	650	73	990	620	105	91
	180L-4-B1	279	350	35.5	13.5	542	283	650	73	990	620	105	91
	200L-4-B0	318	400	41	17.5	644	338	650	73	1045	700	72	91
	225S-4-B0	356	450	47	17.5	718	363	650	73	1105	800	28	91

Note: The suction pipe length H3 has to be cut to the relevant length when the pump motor assembly is fitted onto a reservoir. Take the installation guidelines stated on page 18 into account.

Pump type	Pipe connections			
	Press. connection P ¹⁾	Pressure flange for hose	Suction connection S	Suction pipe Ø
PGH4-20	SAE 3/4" (HD)	25S	SAE 1 1/4"	42
PGH4-25	SAE 3/4" (HD)	25S	SAE 1 1/4"	42
PGH4-32	SAE 3/4" (HD)	25S	SAE 1 1/2"	48.3
PGH4-40	SAE 3/4" (HD)	25S	SAE 1 1/2"	48.3
PGH4-50	SAE 1" (HD)	30S	SAE 1 1/2"	48.3

¹⁾ HD = High pressure series, 6000 PSI

Pump	Electric motor frame size	Dimensions											
		B1	B2	B3	øD	H1	H2	H3	H4	L1	L2	L3	L4
PGH5-63	160M-4-B0	254	350	48	13.5	496	263	650	117.5	917	580	151.5	102.5
	160L-4-B1	254	350	48	13.5	496	263	650	117.5	917	580	151.5	102.5
	180M-4-B0	279	350	35.5	13.5	542	283	650	117.5	1046	620	149.5	102.5
	180L-4-B1	279	350	35.5	13.5	542	283	650	117.5	1046	620	149.5	102.5
	200L-4-B0	318	400	41	17.5	644	338	650	117.5	1101	700	116.5	102.5
	225S-4-B0	356	450	47	17.5	718	363	650	117.5	1165	800	76.5	102.5
	225M-4-B1	356	450	47	17.5	718	363	650	117.5	1165	800	76.5	102.5
PGH5-80	160L-4-B1	254	350	48	13.5	496	263	700	117.5	925	580	155.5	106.9
	180M-4-B0	279	350	35.5	13.5	542	283	700	117.5	1054	620	153.5	106.9
	180L-4-B1	279	350	35.5	13.5	542	283	700	117.5	1054	620	153.5	106.9
	200L-4-B0	318	400	41	17.5	644	338	700	117.5	1109	700	120.5	106.9
	225S-4-B0	356	450	47	17.5	718	363	700	117.5	1173	800	80.5	106.9
	225M-4-B1	356	450	47	17.5	718	363	700	117.5	1173	800	80.5	106.9
	250M-4-B0	616	676	72	23	853	398	700	117.5	1271	850	101.5	106.9
PGH5-100	180M-4-B0	279	350	35.5	13.5	542	283	700	117.5	1063	620	158	111
	180L-4-B1	279	350	35.5	13.5	542	283	700	117.5	1063	620	158	111
	200L-4-B0	318	400	41	17.5	644	338	700	117.5	1118	700	125	111
	225S-4-B0	356	450	47	17.5	718	363	700	117.5	1182	800	85	111
	225M-4-B1	356	450	47	17.5	718	363	700	117.5	1182	800	85	111
	250M-4-B0	616	676	72	23	853	398	700	117.5	1280	850	106	111
	280S-4-B0	667	727	46.5	23	833	378	700	117.5	1355	900	139	111
PGH5-125	180L-4-B1	279	350	35.5	13.5	542	283	700	117.5	1075	620	164	117
	200L-4-B0	318	400	41	17.5	644	338	700	117.5	1130	700	131	117
	225S-4-B0	356	450	47	17.5	718	363	700	117.5	1194	800	91	117
	225M-4-B1	356	450	47	17.5	718	363	700	117.5	1194	800	91	117
	250M-4-B0	616	676	72	23	853	398	700	117.5	1292	850	112	117
	280S-4-B0	667	727	46.5	23	833	378	700	117.5	1367	900	145	117

Note: The suction pipe length H3 has to be cut to the relevant length when the pump motor assembly is fitted onto a reservoir. Take the installation guidelines stated on page 18 into account.

Pump type	Pipe connections			
	Press. connection P ¹⁾	Pressure flange for hose	Suction connection S	Suction pipe Ø
PGH5-63	SAE 1" (HD)	30S	SAE 1 1/2"	48.3
PGH5-80	SAE 1 1/4" (HD)	38S	SAE 2"	60.3
PGH5-100	SAE 1 1/4" (HD)	38S	SAE 2"	60.3
PGH5-125	SAE 1 1/4" (HD)	38S	SAE 2"	60.3

¹⁾ HD = High pressure series, 6000 PSI

Pipe connections

Version .D.F... (with pump safety block and pressure flange)

The pump safety block is fitted to the pump with the pressure flange. The flange to Rexroth standard AB-E 22-14 has a 24 degree connection to ISO 8434 part 1 for a pipe or hose.

Due to the flexible mounting of the motor pump assembly, we recommend that the pressure line connection is via a hose.

With the version shown the hose can be changed without having to loosen the pump safety block.

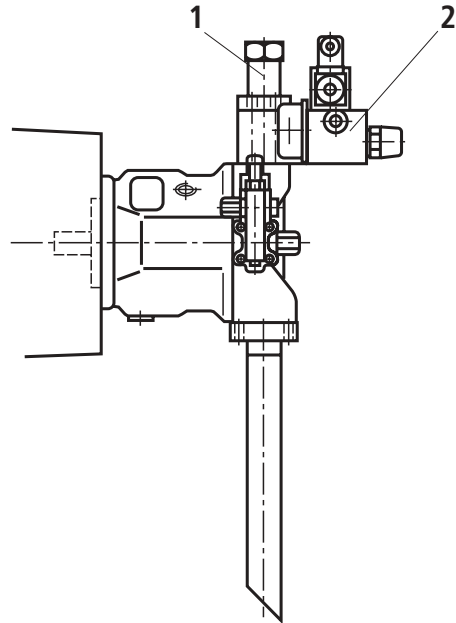

- 1 Pressure flange to Rexroth standard AB-E 22-14
- 2 Pump safety block, type DBA/DBAW to RE 25 890

Installation guidelines

Fluid reservoir

- The usable volume of the reservoir has to match the operating conditions.
- The permissible fluid temperature must not be exceeded, if necessary fit a cooler.

Pipes and connections

- Remove plugs on the pump.
- We recommend the use of precision tubes to DIN 2391 and removable pipe connections.
- Select the internal diameter of the tubes with regard to the connection sizes (suction velocity 0.6 m/s to 1.5 m/s).
- Clean tubes and fittings carefully before assembly.

Filter

- Where possible use return or pressure filters (suction filters only in conjunction with an under pressure switch/clogging indicator).

Pressure fluid

- Please take the specifications stated within catalogue sheet RE 07 075 into account.
- We recommend the use of branded hydraulic fluids.
- Differing types of oil must not be mixed, as sedimentation and a reduction in lubricity may occur.
- Depending on the operating conditions the fluid has to be periodically changed. It also necessary to clean the fluid reservoir.
- Returning fluid must under no circumstances be directly re-circulated, that means the greatest possible distance between the suction and return lines has to be provided.
- Return lines must always be under the oil level.
- Suction lines must be air tight.

Pipe recommendations

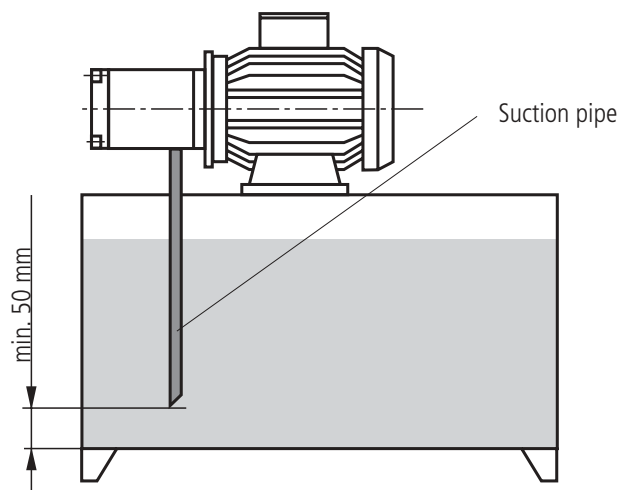

Commissioning guidelines

General

- The motor pump assemblies supplied by ourselves have been tested for function and performance. Changes in any form or manner are not permitted, as this would invalidate any guarantee claim!
- Repairs may only be carried out by the manufacturer or authorised agent or subsidiary. No guarantee will be accepted for commissioning carried out by third parties.

Commissioning

- Check to see if the system has been carefully and cleanly assembled.
- Only fill the system with pressure fluid via a filter with the correct minimum retention rate.
- Take into account the direction of rotation arrow when connecting the electric motor.
- Start-up the pump without load and let it displace oil without pressure for a few seconds in order to provide sufficient lubrication.
- Never run the pump without oil.
- If the pump, after approx. 20 seconds, does not displace oil without any bubbles then the system has to be rechecked.
- After the operating values have been reached, check the pipe connections for leakage and check the operating temperature.

Bleeding

- Before commissioning, the pump housing must be filled with oil.



Important guidelines

- Assembly, maintenance and servicing of the pump motor assembly must only be carried out by authorised, trained and instructed personnel!
- The pump motor assembly must only be operated within the permitted limits!
- When carrying out any work on the unit, switch the system to zero pressure! Unauthorised conversions and modifications which affect the safety and function are not permitted!
- Provide protective measure and **do not** remove any existing protective devices.
- Ensure that the fixing bolts are correctly fitted! (Take into account the prescribed tightening torque!)
- The general valid safety and accident prevention regulations must be adhered to!

Note with reference to the EC machinery guidelines 89/392 EWG annex II section B; manufacturer declaration:

The supplied assemblies have been manufactured in accordance with the harmonised standards prEN 982, prEN 983 DIN EN 292 and DIN EN 60 204-1.

Commissioning may not take place until it has been confirmed that the machine, into which the assembly is to be installed, conforms with the regulations stated within the EG guidelines.

Engineering guidelines

Comprehensive instructions and proposals can be found in the Hydraulic Trainer, volume 3, RE 00 281, "Planning and design of hydraulic power systems."

Noise

The noise pressure levels for pumps stated in the catalogue sheets are measured in line with DIN 45 635, sheet 26. **Only** the pump noise emissions are shown.

External influences (place of use, pipe work, etc.) have **not** been taken into account. The values stated in the standard are only valid for one pump.

The noise pressure level at the place of use can, in unfavourable circumstances, increase by up to 10 dB(A) or the values of the pump itself.

Bosch Rexroth AG
Industrial Hydraulics

D-97813 Lohr am Main
Zum Eisengießer 1 • D-97816 Lohr am Main
Telefon 0 93 52 / 18-0
Telefax 0 93 52 / 18-23 58 • Telex 6 89 418-0
eMail documentation@boschrexroth.de
Internet www.boschrexroth.de

Bosch Rexroth Limited

Cromwell Road, St Neots
Cambs, PE19 2ES
Tel: 0 14 80/22 32 56
Fax: 0 14 80/21 90 52
E-mail: info@boschrexroth.co.uk

The data specified above only serves to describe the product. No statements concerning a certain condition or suitability for a certain application can be derived from our information. It must be remembered that our products are subject to a natural process of wear and ageing.