

RE 17 328/02.03

Replaces: 01.01

**Hydraulic cylinder
Type CDM1**

Series 1X

Nominal pressure 160 bar (16 MPa)

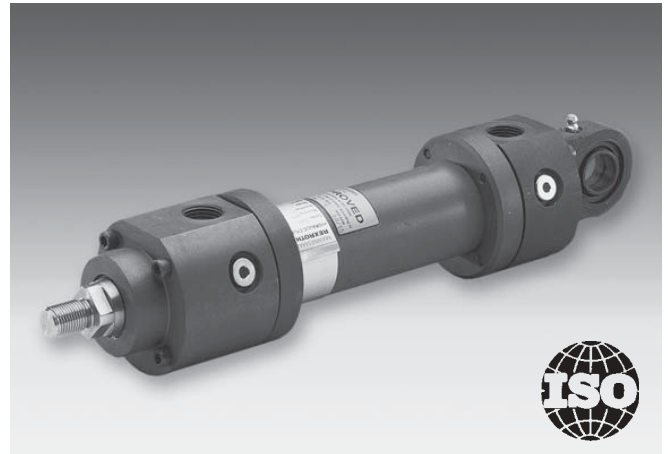

H/A 4652/95

Type CDM1MP5/...

Overview of contents

Contents	Page
Technical data	2
Areas, forces, flows	2
Ordering details	3
Cylinder weight	4
Tolerances to ISO 8135	4
Mounting style overview	5
Mounting style M00	6
Mounting styles MP3/MP5	8
Mounting styles MF1/MF2	10
Mounting styles MF3/MF4	12
Mounting style MT4	14
Mounting style MS2	16
Flange connections	18
Drain oil connection	19
Test point	19
Potentiometer (option P)	20
Proximity switches (option E)	22
Cable for potentiometer and proximity switch	23
Self-aligning clevis	24
Mounting block	25
Pin	25
Buckling	26
Permissible stroke lengths	26
End position cushioning/damping capacity	28
Spare parts	30
Tightening torques	31
Seal kits	31

Features

- Standards: ISO 6020/1
CETOP RP 58 H
NF E 48-015
VW 39 D 920
- Max. operating pressure up to 240 bar
- 9 mounting styles
- Piston Ø: 25 to 200 mm
- Piston rod Ø: 14 to 140 mm
- Stroke lengths up to 3 m
- Self adjusting
end position cushioning



© 2003

by Bosch Rexroth AG, Industrial Hydraulics, D-97813 Lohr am Main

All rights reserved. No part of this document may be reproduced or stored, processed, duplicated or circulated using electronic systems, in any form or by means, without the prior written authorisation of Bosch Rexroth AG. In the event of contravention of the above provisions, the contravening party is obliged to pay compensation.

Technical data

Standards:

The installation dimensions and mounting styles of the cylinders meet the requirements of the following standards
ISO 6020/1, CETOP RP 58 H, NF E 48-015 and VW 39 D 920.

Nominal pressure: 160 bar (16 MPa)

Static proof pressure: 240 bar (24 MPa)

With extreme shock loads the fixing elements and piston rod threads have to be laid out, taking the fatigue limits into account.

Max. operating pressure: 240 bar (24 MPa)

Dependent on the cylinder version and the application, suitable for operating pressures up to 240 bar (24 MPa) (up to a maximum of 2 million load changes).

Installation: Optional

Pressure fluid:

Mineral oils DIN 51 524 (HL, HLP)

Phosphate ester (HFD-R)

Water glycol HFC on request.

Pressure fluid temperature range: $-20\text{ }^{\circ}\text{C}$ bis $+80\text{ }^{\circ}\text{C}$

Viscosity range: 2.8 to 380 mm²/s

ISO cleanliness class:

Maximum permissible degree of contamination of the pressure fluid is to ISO 4406 (C) class 20/18/15.

Stroke velocity: Up to 0.5 m/s
(depending on the connection ports)

Bleed screw as standard.

Delivery inspection: Every cylinder is tested according to the Bosch Rexroth standards.

Cylinders can be offered as special versions, where the application details deviate from the stated technical data.

Catalogue sheet RE 07 100 must be taken into account for **installation, commissioning** and **maintenance** of hydraulic cylinders.

Area, forces, flows

Piston	Piston rod	Area ratio	Areas			Force at 160 bar ¹⁾			Flow at 0.1 m/s ²⁾		
			Piston	Rod	Annulus	Pressure	Diff.	Pulling	Out	Diff.	In
AL	MM	φ	A_1	A_2	A_3	F_1	F_2	F_3	q_{V1}	q_{V2}	q_{V3}
Ø mm	Ø mm	A_1/A_3	cm ²	cm ²	cm ²	kN	kN	kN	L/min	L/min	L/min
25	14	1.46	4.91	1.54	3.37	7.85	2.44	5.37	2.9	0.9	2.0
	18	2.08		2.54	2.36		4.07	3.76		1.5	1.4
32	18	1.46	8.04	2.54	5.50	12.80	4.07	8.78	4.8	1.5	3.3
	22	1.90		3.80	4.24		6.08	6.76		2.3	2.5
40	22	1.43	12.56	3.80	8.76	20.00	6.08	14.03	7.5	2.3	5.2
	28	1.96		6.16	6.41		9.82	10.24		3.7	3.8
50	28	1.46	19.63	6.16	13.47	31.30	9.82	21.55	11.7	3.7	8.1
	36	2.08		10.18	9.46		16.29	15.10		6.1	5.6
63	36	1.48	31.17	10.18	20.99	49.80	16.29	33.56	18.7	6.1	12.6
	45	2.04		15.90	15.27		25.40	24.41		9.5	9.2
80	45	1.46	50.26	15.90	34.36	80.30	25.40	54.96	30.2	9.5	20.7
	56	1.96		24.63	25.63		39.30	40.99		14.8	15.4
100	56	1.46	78.54	24.63	53.91	125.00	39.30	86.22	47.1	14.8	32.3
	70	1.96		38.48	40.06		61.50	64.04		23.1	24.0
125	70	1.46	122.72	38.48	84.24	196.00	61.50	134.7	73.6	23.1	50.5
	90	2.08		63.62	59.10		101.00	94.49		38.2	35.4
160	90	1.46	201.06	63.62	137.00	321.00	101.00	219.8	120.6	38.2	82.4
	110	1.90		95.06	106.00		151.00	169.5		57.0	63.6
200	110	1.43	314.16	95.06	219.09	502.6	152.00	350.6	188.5	57.0	131.5
	140	1.96		153.96	160.20		246.30	256.3		92.4	96.1

Note

¹⁾ Theoretical force (efficiency not taken into account)

²⁾ Stroke velocity

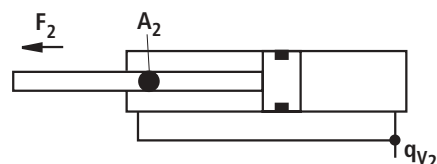
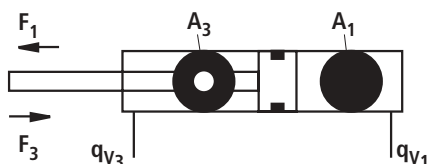

Ordering details

CD M1 / / / A 1X / 1

Differential cylinder = CD

Series = M1

Mounting styles

Without mounting = M00
 Plain rear clevis mounting = MP3
 Self-aligning rear clevis mounting = MP5
 Rectangular flange at head ¹⁾ = MF1
 Rectangular flange at base ¹⁾ = MF2
 Round flange at head = MF3
 Round flange at base = MF4
 Trunnion mounting ²⁾ = MT4
 foot mounting = MS2

Piston Ø (25 - 200 mm)

See page 2

Piston rods - Ø (14 - 140 mm)

See page 2

Stroke length in mm

Design principle

Head and base flanged = A

Series

10 to 19 unchanged installation and connection dimensions = 1X

Pipe connections

BSP- pipe threads - ISO 228/1 = B

Flange connection ISO 6162 Tab.3 (Δ SAE 3000 PSI) ⁵⁾ = F

Connection ports/position at head and base = 1



Viewed on piston rod

Notes

- 1) = Only piston Ø 25 - 125 mm
 2) = Always enter the XV position of the trunnion in mm in clear text
 3) = Only piston Ø 40 - 100 mm
 Only for strokes 25 to 520 mm
 Only M00; MF1; MF3; MT4; MP5
 Flange connection „F“ not possible
 Seal versions „A“ and „V“ not possible
 End position cushioning not possible
 4) = Only piston Ø 40 - 200 mm
 Flange connection „F“ not possible
 Seal version „A“ not possible
 Mounting style „MS2“ not possible

Y = ⁶⁾

Option 2
 State the piston rod extension LY in mm in clear text
 Without option

W =

B = ⁵⁾

E = ⁴⁾

P = ³⁾

W =

Option 1

Drain port

Inductive

proximity switches

Position measuring system,

potentiometer

Without option

Seal versions

Suitable for mineral oil – DIN 51524

HL, HLP

M = Standard seal system

T = ⁷⁾ Servo quality/reduced

friction

A = ⁵⁾ Chevron seal kits

Suitable for phosphate ester

HFD-R

V = Standard seal system

(up to + 150°C)

End position cushioning

D = On both sides, self adjusting

K = Rear end, self adjusting

S = Head side, self adjusting

U = Without

Piston rod end

H = Thread (VW standard VW 39 D 920)

G = Thread (ISO 6020/1)

F = Piston rod end H with mounted

self-aligning clevis (see page 24)

K = Piston rod end G with mounted

self-aligning clevis (see page 24)

Piston rod versions

C = Hard chromium plated

H = ⁸⁾ Hardened and hard chromium plated

L = ⁹⁾ Stainless steel piston rod X4CrNiMoN 2752;

EN10088; hard chromium plated

5) = Only piston Ø 50 - 200 mm

6) = Not in combination with position measuring system „P“

7) = Only piston rod Ø 36 - 140 mm

8) = Only piston rod Ø 14 - 110 mm

9) = Max. operating pressure 160 bar (16 MPa)

Ordering examples:

CDM1MT4/50/28/550A1X/B1CHDMWW, XV = 175 mm

CDM1MF3/200/110/950A1X/B1CHKAWW

Cylinder weight

Piston AL Ø	Piston rod MM Ø	CD cylinder at 0 mm stroke length						Per 100 mm stroke length kg
		M00 kg	MP3/MP5 kg	MF1/MF2 kg	MF3/MF4 kg	MT4 kg	MS2 kg	
25	14	2.7	2.9	3.1	3.2	3.1	3.5	0.33
	18	2.8	3.0	3.2	3.3	3.2	3.6	0.41
32	18	3.7	4.0	4.4	4.7	4.4	6.1	0.55
	22	3.9	4.2	4.6	4.9	4.6	6.3	0.65
40	22	6.0	6.4	7.2	7.2	7.3	8.4	0.85
	28	6.2	6.6	7.4	7.4	7.5	8.6	1.04
50	28	7.8	8.3	9.4	9.9	9.9	11.8	1.18
	36	7.9	8.4	9.5	10.0	10	11.9	1.48
63	36	13.4	14.3	16.1	17.7	16.7	19.8	1.80
	45	13.8	14.7	16.5	18.1	17.1	20.2	2.30
80	45	19.4	21.0	23.6	24.5	25.0	30.4	2.90
	56	19.9	21.5	24.1	25.0	25.5	30.9	3.50
100	56	35.7	39.0	41.9	45.1	45.9	54.1	4.60
	70	36.7	40.0	43.9	46.1	46.9	55.1	5.70
125	70	57.4	62.2	65.7	67.0	74.4	84.6	7.20
	90	58.6	63.4	66.9	68.2	75.6	85.8	9.20
160	90	103	113	–	118	124	143	11.5
	110	106	116	–	121	127	146	13.9
200	110	183	203	–	207	229	253	15.3
	140	185	205	–	209	231	255	19.9

Tolerances to ISO 8135

Installation dimensions	W	WC	XC ¹⁾	XO ¹⁾	XS	XV	ZF ¹⁾	ZP ¹⁾	Stroke tolerances
Mounting style	MF1	MF3	MP3	MP5	MS2	MT4	MF2	MF4	
Stroke length	Tolerances								
0 – 499	± 2	± 1.5	± 1.5	± 1.5	± 2	± 2	± 1.5	± 1.5	+ 3
50 – 1249	± 2.8	± 2.8	± 2	± 2	± 2.8	± 2.8	± 2	± 2	+ 4
1250 – 3000	± 4	± 4	± 3	± 3	± 4	± 4	± 3	± 3	+ 6

Note

¹⁾ Stroke length included

Mounting style overview

CDM1 M00

See pages 6, 7

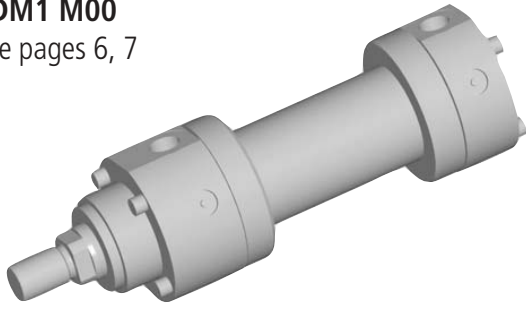

CDM1 MP3

See pages 8, 9

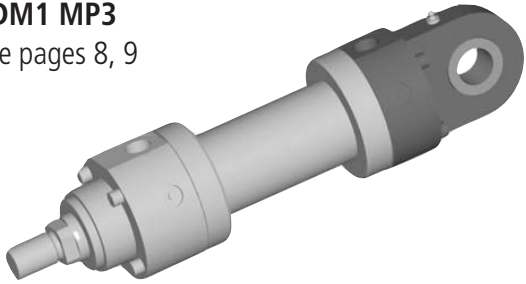

CDM1 MP5

See pages 8, 9

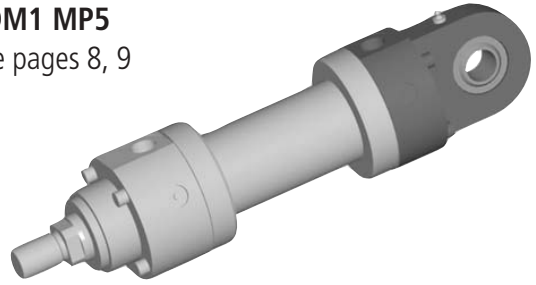

CDM1 MF1

See pages 10, 11

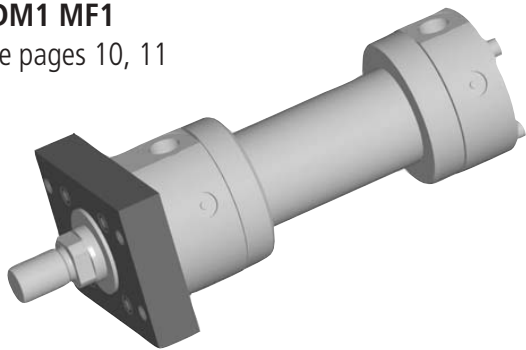

CDM1 MF2

See pages 10, 11

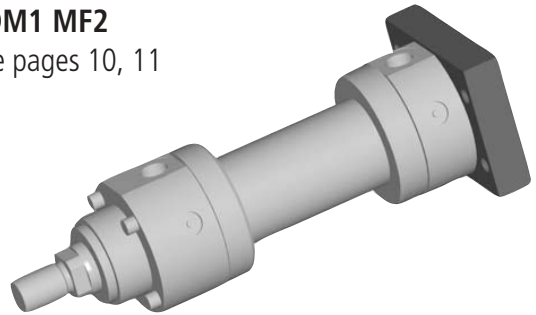

CDM1 MF3

See pages 12, 13

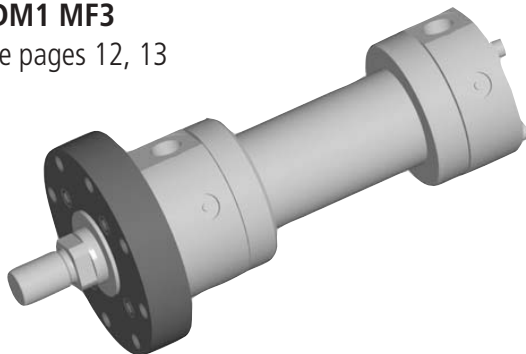

CDM1 MF4

See pages 12, 13

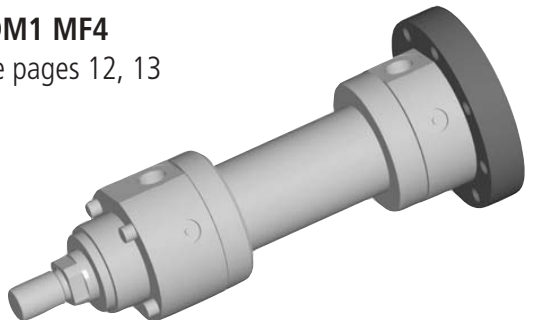

CDM1 MT4

See pages 14, 15

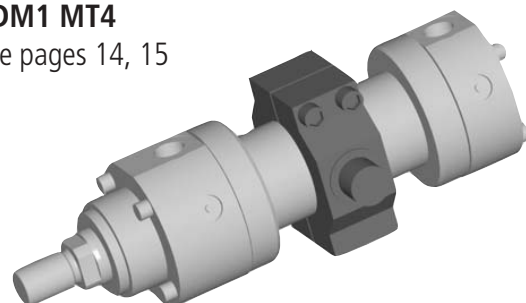

CDM1 MS2

See pages 16, 17

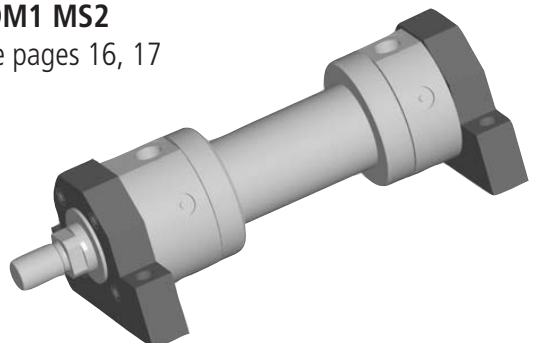

Mounting style M00

CDM1 M00

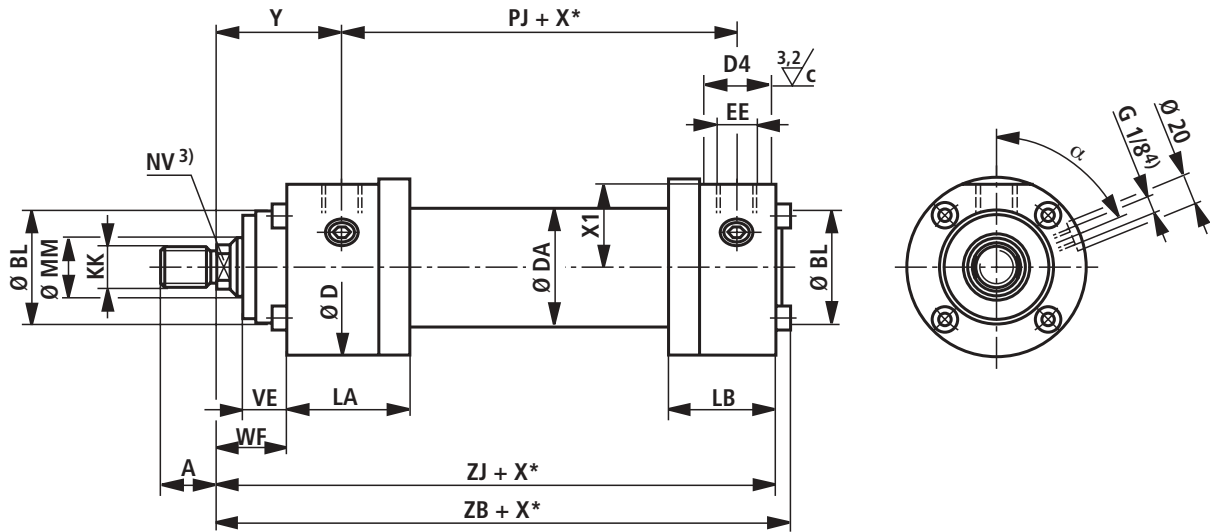

Dimensions CDM1 (in mm)

AL Ø	MM Ø	KK ¹⁾ ISO 6020/1	A ¹⁾	KK ²⁾ VW 39 D920	A ²⁾	NV ³⁾	BL	D max.	DA max.	D4	EE
25	14	M12x1.25	16	–	–	12	32	56	33	25	G1/4
	18	M14x1.5	18	M12x1.25	16	14					
32	18	M14x1.5	18	–	–	14	40	67	41	28	G3/8
	22	M16x1.5	22	M14x1.5	18	17					
40	22	M16x1.5	22	–	–	17	50	78	52	34	G1/2
	28	M20x1.5	28	M16x1.5	22	22					
50	28	M20x1.5	28	–	–	22	60	95	62	34	G1/2
	36	M27x2	36	M20x1.5	28	28					
63	36	M27x2	36	–	–	28	73	116	77	42	G3/4
	45	M33x2	45	M27x2	36	36					
80	45	M33x2	45	–	–	36	93	130	98	42	G3/4
	56	M42x2	56	M33x2	45	46					
100	56	M42x2	56	–	–	46	114	158	122	47	G1
	70	M48x2	63	M42x2	56	60					
125	70	M48x2	63	–	–	60	140	192	152	47	G1
	90	M64x3	85	M48x2	63	75					
160	90	M64x3	85	–	–	75	168	238	193	58	G11/4
	110	M80x3	95	M64x3	85	90					
200	110	M80x3	95	–	–	90	200	285	240	58	G11/4
	140	M100x3	112	M80x3	95	120					

AL Ø	MM Ø	Y	PJ	X1	VE	WF	ZB max.	ZJ	α	LA ±1	LB ±1
25	14	58	77	25.5	15	28	158	150	90°	59	44
	18										
32	18	64	89	30	19	32	178	170	90°	65	50
	22										
40	22	71	97	35	19	32	198	190	67°	75	58
	28										
50	28	72	111	44	24	38	213	205	67°	74	62
	36										
63	36	82	117	54	29	45	234	224	67°	82	70
	45										
80	45	91	134	62	36	54	260	250	45°	89	77
	56										
100	56	108	162	75	37	57	310	300	45°	114	93
	70										
125	70	121	174	92	37	60	335	325	45°	127	96
	90										
160	90	143	191	115	41	66	380	370	38°	155	114
	110										
200	110	190	224	138	45	75	480	450	38°	209	130
	140										

Notes

AL = Piston Ø

MM = Piston rod Ø

X* = Stroke length

1) = Thread version **G** (to ISO 6020/1)

2) = Thread version **H** (VW standard VW 39 D 920)

3) = Square or hexagon spanner flats

4) = Bleeding/measuring connection is plugged

Mounting styles MP3/MP5

CDM1 MP3

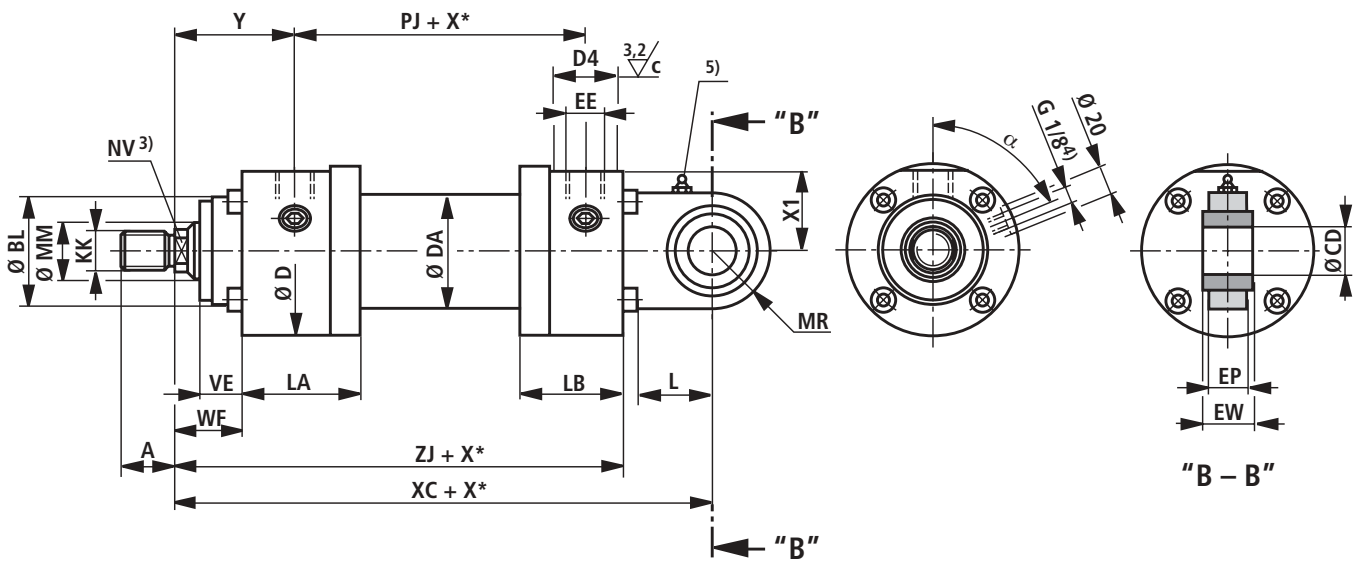

CDM1 MP5

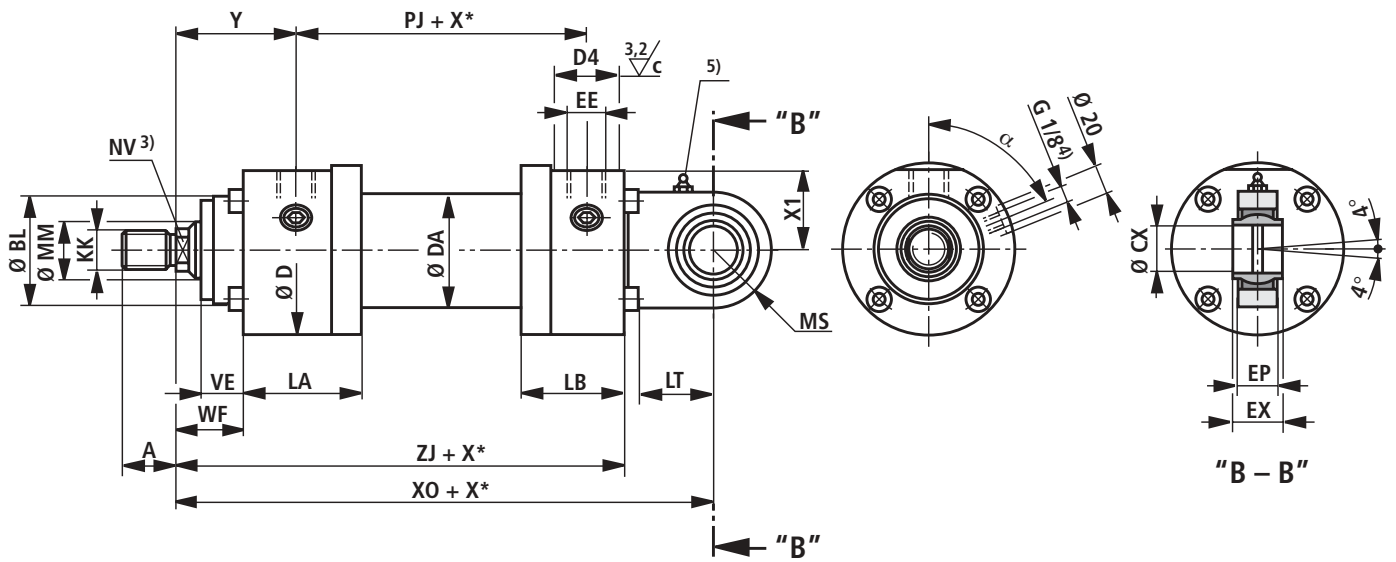

Dimensions MP3/MP5 (in mm)

AL Ø	MM Ø	KK ¹⁾ ISO 6020/1	A ¹⁾	KK ²⁾ VW 39 D920	A ²⁾	NV ³⁾	BL	D max.	DA max.	D4	EE	Y	PJ
25	14	M12x1.25	16	–	–	12	32	56	33	25	G1/4	58	77
	18	M14x1.5	18	M12x1.25	16	14							
32	18	M14x1.5	18	–	–	14	40	67	41	28	G3/8	64	89
	22	M16x1.5	22	M14x1.5	18	17							
40	22	M16x1.5	22	–	–	17	50	78	52	34	G1/2	71	97
	28	M20x1.5	28	M16x1.5	22	22							
50	28	M20x1.5	28	–	–	22	60	95	62	34	G1/2	72	111
	36	M27x2	36	M20x1.5	28	28							
63	36	M27x2	36	–	–	28	73	116	77	42	G3/4	82	117
	45	M33x2	45	M27x2	36	36							
80	45	M33x2	45	–	–	36	93	130	98	42	G3/4	91	134
	56	M42x2	56	M33x2	45	46							
100	56	M42x2	56	–	–	46	114	158	122	47	G1	108	162
	70	M48x2	63	M42x2	56	60							
125	70	M48x2	63	–	–	60	140	192	152	47	G1	121	174
	90	M64x3	85	M48x2	63	75							
160	90	M64x3	85	–	–	75	168	238	193	58	G1 1/4	143	191
	110	M80x3	95	M64x3	85	90							
200	110	M80x3	95	–	–	90	200	285	240	58	G1 1/4	190	224
	140	M100x3	112	M80x3	95	120							

AL Ø	MM Ø	X1	VE	WF	ZJ	XC/XO	CD/CX H9/H7	EP	EW/EX h12	L/LT min.	MR/MS max.	α	LA ±1	LB ±1
25	14	25.5	15	28	150	178	12	10.6	12	16	16	90°	59	44
	18													
32	18	30	19	32	170	206	16	14	16	20	20	90°	65	50
	22													
40	22	35	19	32	190	231	20	18	20	25	25	67°	75	58
	28													
50	28	44	24	38	205	257	25	23	25	32	32	67°	74	62
	36													
63	36	54	29	45	224	289	32	27	32	40	40	67°	82	70
	45													
80	45	62	36	54	250	332	40	32	40	50	50	45°	89	77
	56													
100	56	75	37	57	300	395	50	40	50	63	63	45°	114	93
	70													
125	70	92	37	60	325	428	63	52	63	71	71	45°	127	96
	90													
160	90	115	41	66	370	505	80	66	80	90	90	38°	155	114
	110													
200	110	138	45	75	450	615	100	84	100	112	112	38°	209	130
	140													

Notes

AL = Piston Ø

MM = Piston rod Ø

X* = Stroke length

1) = Thread version **G** (to ISO 6020/1)

2) = Thread version **H** (VW standard VW 39 D 920)

3) = Square or hexagon spanner flats

4) = Bleeding/measuring connection is plugged

5) = Cone head grease nipple form A to DIN 71 412

Mounting styles MF1/MF2

CDM1 MF1

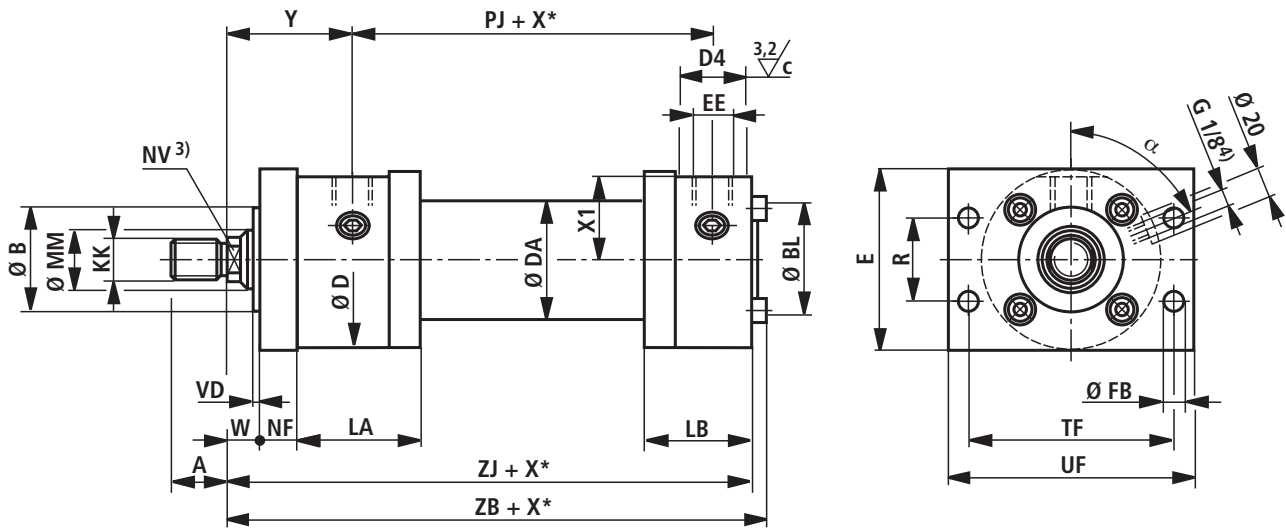

CDM1 MF2

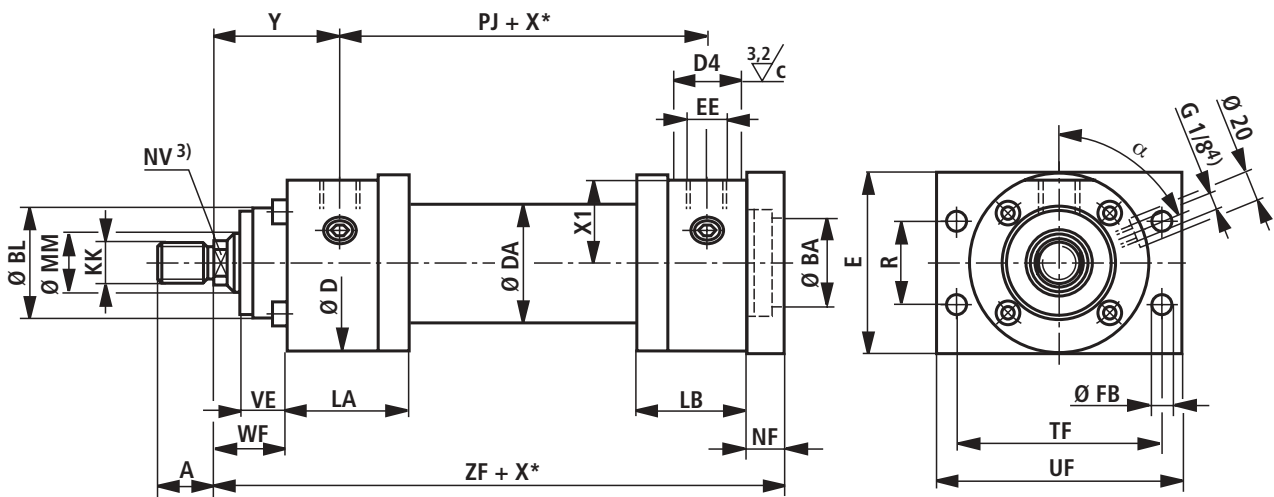

Dimensions MF1/MF2 (in mm)

AL Ø	MM Ø	KK ¹⁾ ISO 6020/1	A ¹⁾	KK ²⁾ VW 39 D920	A ²⁾	NV ³⁾	BL	D	DA max.	D4 max.	EE	Y	PJ	X1	VE
25	14	M12x1.25	16	—	—	12	32	56	33	25	G1/4	58	77	25.5	15
	18	M14x1.5	18	M12x1.25	16	14									
32	18	M14x1.5	18	—	—	14	40	67	41	28	G3/8	64	89	30	19
	22	M16x1.5	22	M14x1.5	18	17									
40	22	M16x1.5	22	—	—	17	50	78	52	34	G1/2	71	97	35	19
	28	M20x1.5	28	M16x1.5	22	22									
50	28	M20x1.5	28	—	—	22	60	95	62	34	G1/2	72	111	44	24
	36	M27x2	36	M20x1.5	28	28									
63	36	M27x2	36	—	—	28	73	116	77	42	G3/4	82	117	54	29
	45	M33x2	45	M27x2	36	36									
80	45	M33x2	45	—	—	36	93	130	98	42	G3/4	91	134	62	36
	56	M42x2	56	M33x2	45	46									
100	56	M42x2	56	—	—	46	114	158	122	47	G1	108	162	75	37
	70	M48x2	63	M42x2	56	60									
125	70	M48x2	63	—	—	60	140	192	152	47	G1	121	174	92	37
	90	M64x3	85	M48x2	63	75									

AL Ø	MM Ø	WF	NF	VD	W	B/BA f8/E9	ZJ	ZB max.	ZF	E max.	R js 13	TF js 13	UF max.	FB H13	α	LA ±1	LB ±1
25	14	28	12	3	16	32	150	158	162	60	28.7	69.2	85	6.6	90°	59	44
	18																
32	18	32	16	3	16	40	170	178	186	70	35.2	85	105	9	90°	65	50
	22																
40	22	32	16	3	16	50	190	198	206	80	40.6	98	115	9	67°	75	58
	28																
50	28	38	20	4	18	60	205	213	225	100	48.2	116.4	140	11	67°	74	62
	36																
63	36	45	25	4	20	70	224	234	249	120	55.5	134	160	13.5	67°	82	70
	45																
80	45	54	32	4	22	85	250	260	282	135	63.1	152.5	185	17.5	45°	89	77
	56																
100	56	57	32	5	25	106	300	310	332	160	76.5	184.8	225	22	45°	114	93
	70																
125	70	60	32	5	28	132	325	335	357	195	90.2	217.1	255	22	45°	127	96
	90																

Notes

AL = Piston Ø

MM = Piston rod Ø

X* = Stroke length

¹⁾ = Thread version **G** (to ISO 6020/1)

²⁾ = Thread version **H** (VW standard VW 39 D 920)

³⁾ = Square or hexagon spanner flats

⁴⁾ = Bleeding/measuring connection is plugged

Mounting styles MF3/MF4

CDM1 MF3

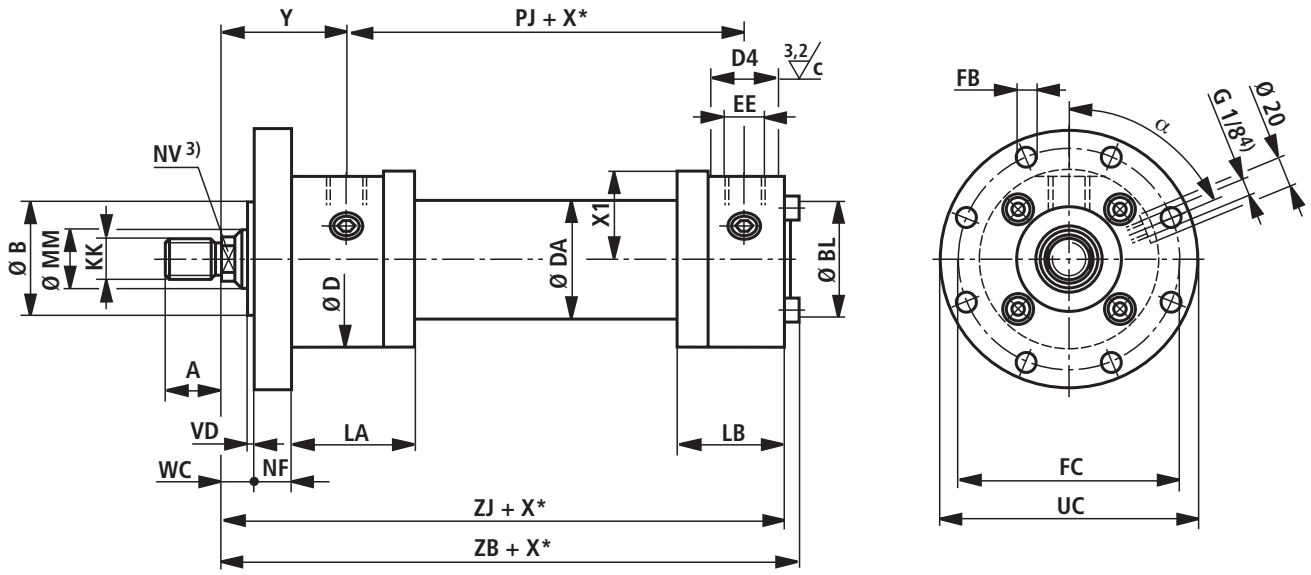

CDM1 MF4

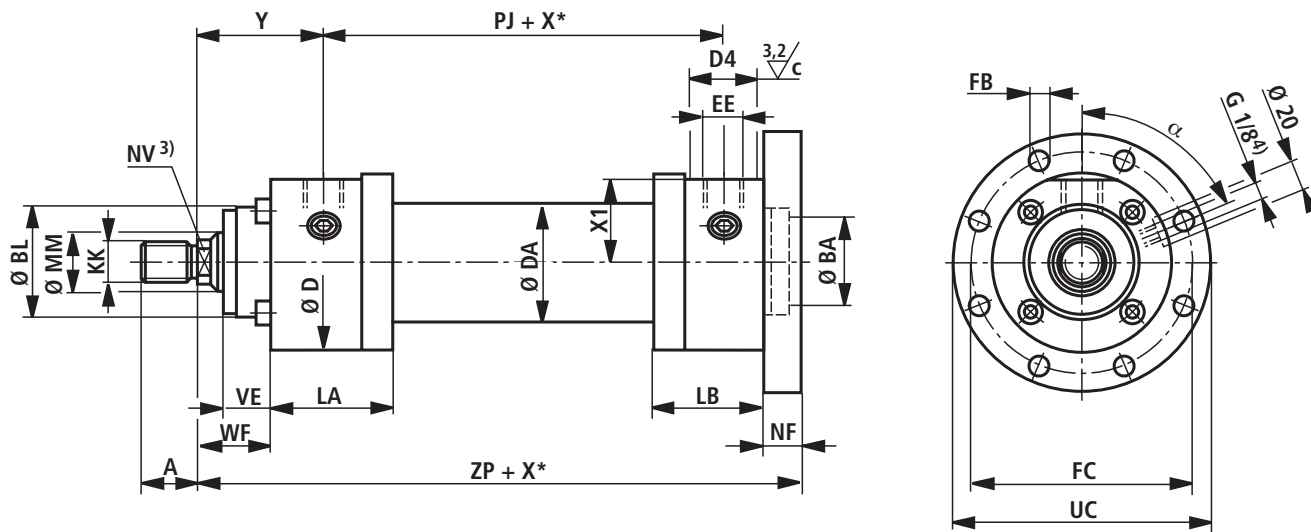

Dimensions MF3/MF4 (in mm)

AL Ø	MM Ø	KK ¹⁾ ISO 6020/1	A ¹⁾	KK ²⁾ VW 39 D920	A ²⁾	NV ³⁾	BL	D max.	DA max.	D4	EE	Y	PJ	X1	VE
25	14	M12x1.25	16	—	—	12	32	56	33	25	G1/4	58	77	25.5	15
	18	M14x1.5	18	M12x1.25	16	14									
32	18	M14x1.5	18	—	—	14	40	67	41	28	G3/8	64	89	30	19
	22	M16x1.5	22	M14x1.5	18	17									
40	22	M16x1.5	22	—	—	17	50	78	52	34	G1/2	71	97	35	19
	28	M20x1.5	28	M16x1.5	22	22									
50	28	M20x1.5	28	—	—	22	60	95	62	34	G1/2	72	111	44	24
	36	M27x2	36	M20x1.5	28	28									
63	36	M27x2	36	—	—	28	73	116	77	42	G3/4	82	117	54	29
	45	M33x2	45	M27x2	36	36									
80	45	M33x2	45	—	—	36	93	130	98	42	G3/4	91	134	62	36
	56	M42x2	56	M33x2	45	46									
100	56	M42x2	56	—	—	46	114	158	122	47	G1	108	162	75	37
	70	M48x2	63	M42x2	56	60									
125	70	M48x2	63	—	—	60	140	192	152	47	G1	121	174	92	37
	90	M64x3	85	M48x2	63	75									
160	90	M64x3	85	—	—	75	168	238	193	58	G1 1/4	143	191	115	41
	110	M80x3	95	M64x3	85	90									
200	110	M80x3	95	—	—	90	200	285	240	58	G1 1/4	190	224	138	45
	140	M100x3	112	M80x3	95	120									

AL Ø	MM Ø	WF	NF	VD	WC	B/BA f8/E9	ZJ	ZB max	ZP	FC js13	UC -2	FB H13	α	LA ±1	LB ±1
25	14	28	12	3	16	32	150	158	162	75	90	6.6	90°	59	44
	18														
32	18	32	16	3	16	40	170	178	186	92	110	9	90°	65	50
	22														
40	22	32	16	3	16	50	190	198	206	106	125	9	67°	75	58
	28														
50	28	38	20	4	18	60	205	213	225	126	148	11	67°	74	62
	36														
63	36	45	25	4	20	70	224	234	249	145	170	13.5	67°	82	70
	45														
80	45	54	32	4	22	85	250	260	282	165	195	17.5	45°	89	77
	56														
100	56	57	32	5	25	106	300	310	332	200	238	22	45°	114	93
	70														
125	70	60	32	5	28	132	325	335	357	235	272	22	45°	127	96
	90														
160	90	66	36	5	30	160	370	380	406	280	316	22	38°	155	114
	110														
200	110	75	40	5	35	200	450	480	490	340	385	26	38°	209	130
	140														

Notes

AL = Piston Ø

MM = Piston rod Ø

X* = Stroke length

1) = Thread version **G** (to ISO 6020/1)

2) = Thread version **H** (VW standard VW 39 D 920)

3) = Square or hexagon spanner flats

4) = Bleeding/measuring connection is plugged

Mounting style MT4

CDM1 MT4: AL-Ø 25-125 mm

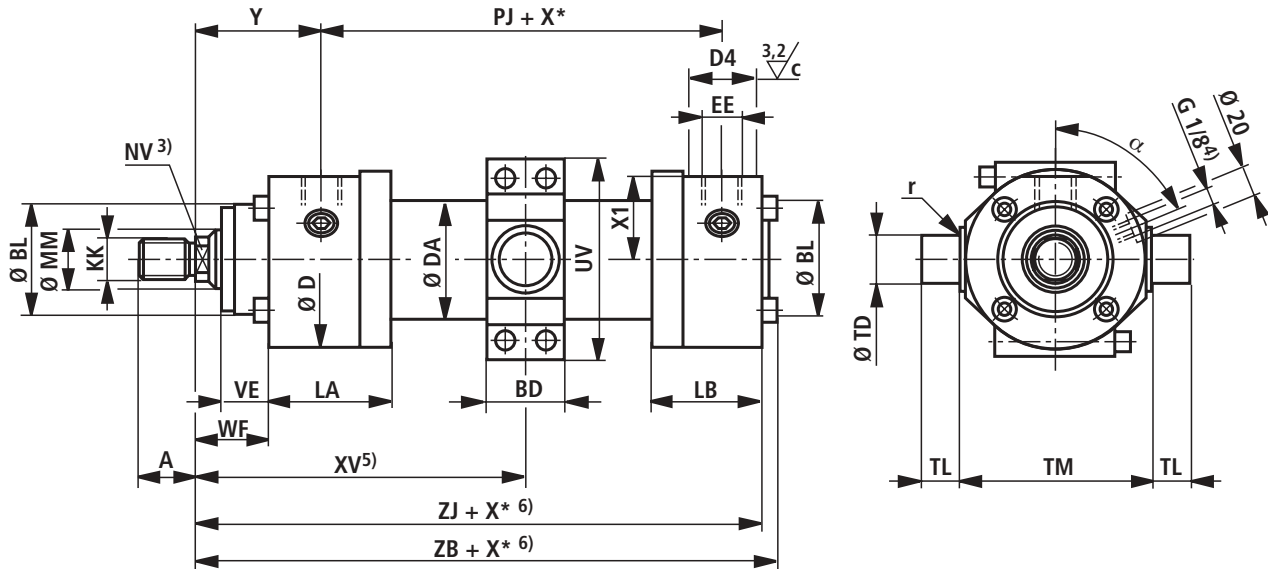

CDM1 MT4: AL-Ø 160-200 mm

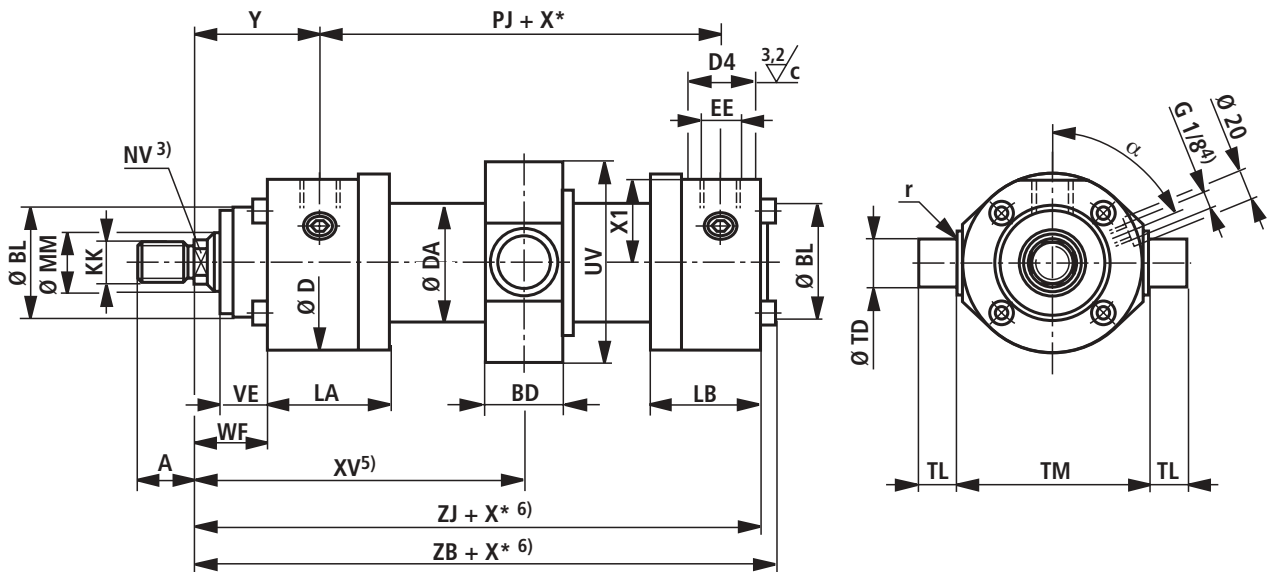

Dimensions MT4 (in mm)

AL Ø	MM Ø	KK ¹⁾ ISO 6020/1	A ¹⁾	KK ²⁾ VW 39 D920	A ²⁾	NV ³⁾	BL	D max.	DA max.	D4	EE	Y	PJ	X1	VE
25	14	M12x1.25	16	—	—	12	32	56	33	25	G1/4	58	77	25.5	15
	18	M14x1.5	18	M12x1.25	16	14									
32	18	M14x1.5	18	—	—	14	40	67	41	28	G3/8	64	89	30	19
	22	M16x1.5	22	M14x1.5	18	17									
40	22	M16x1.5	22	—	—	17	50	78	52	34	G1/2	71	97	35	19
	28	M20x1.5	28	M16x1.5	22	22									
50	28	M20x1.5	28	—	—	22	60	95	62	34	G1/2	72	111	44	24
	36	M27x2	36	M20x1.5	28	28									
63	36	M27x2	36	—	—	28	73	116	77	42	G3/4	82	117	54	29
	45	M33x2	45	M27x2	36	36									
80	45	M33x2	45	—	—	36	93	130	98	42	G3/4	91	134	62	36
	56	M42x2	56	M33x2	45	46									
100	56	M42x2	56	—	—	46	114	158	122	47	G1	108	162	75	37
	70	M48x2	63	M42x2	56	60									
125	70	M48x2	63	—	—	60	140	192	152	47	G1	121	174	92	37
	90	M64x3	85	M48x2	63	75									
160	90	M64x3	85	—	—	75	168	238	193	58	G1 1/4	143	191	115	41
	110	M80x3	95	M64x3	85	90									
200	110	M80x3	95	—	—	90	200	285	240	58	G1 1/4	190	224	138	45
	140	M100x3	112	M80x3	95	120									

AL Ø	MM Ø	WF	ZJ	ZB max.	BD	UV	r	TD f8	TL js16	TM h12	XV ⁵⁾ min.	XV ⁵⁾ max.	X* ⁶⁾ min.	α	LA ±1	LB ±1
25	14	28	150	158	20	64	1	12	10	63	98	95+X*	3	90°	59	44
	18			178								107+X*				
32	18	32	170	178	25	75	1	16	12	75	111	107+X*	4	90°	65	50
	22			198								114+X*				
40	22	32	190	198	35	86	1.5	20	16	90	126	114+X*	12	67°	75	58
	28			213								122+X*				
50	28	38	205	213	40	100	1.5	25	20	105	133	122+X*	11	67°	74	62
	36			234								128+X*				
63	36	45	224	234	50	126	2	32	25	120	153	128+X*	25	67°	82	70
	45			260								138+X*				
80	45	54	250	260	65	145	2,5	40	32	135	178	138+X*	39	45°	89	77
	56			310								165+X*				
100	56	57	300	310	80	175	2,5	50	40	160	213	165+X*	48	45°	114	93
	70			335								177+X*				
125	70	60	325	335	100	215	3	63	50	195	239	177+X*	62	45°	127	96
	90			380								190+X*				
160	90	66	370	380	100	250	3	80	63	240	287	190+X*	97	38°	155	114
	110			480								237+X*				
200	110	75	450	480	125	300	3.5	100	80	295	367	237+X*	130	38°	209	130
	140			125								209				

Notes

AL = Piston Ø

MM = Piston rod Ø

X* = Stroke length

1) = Thread version **G** (nach ISO 6020/1)

2) = Thread version **H** (VW standard VW 39 D 920)

3) = Square or hexagon spanner flats

4) = Bleeding/measuring connection is plugged

5) = Dimension "XV" must be stated in clear text in the order
(XV_{min} and XV_{max} must be taken into account)

6) = Min. stroke length "X*min." must be taken into account

Mounting style MS2

CDM1 MS2

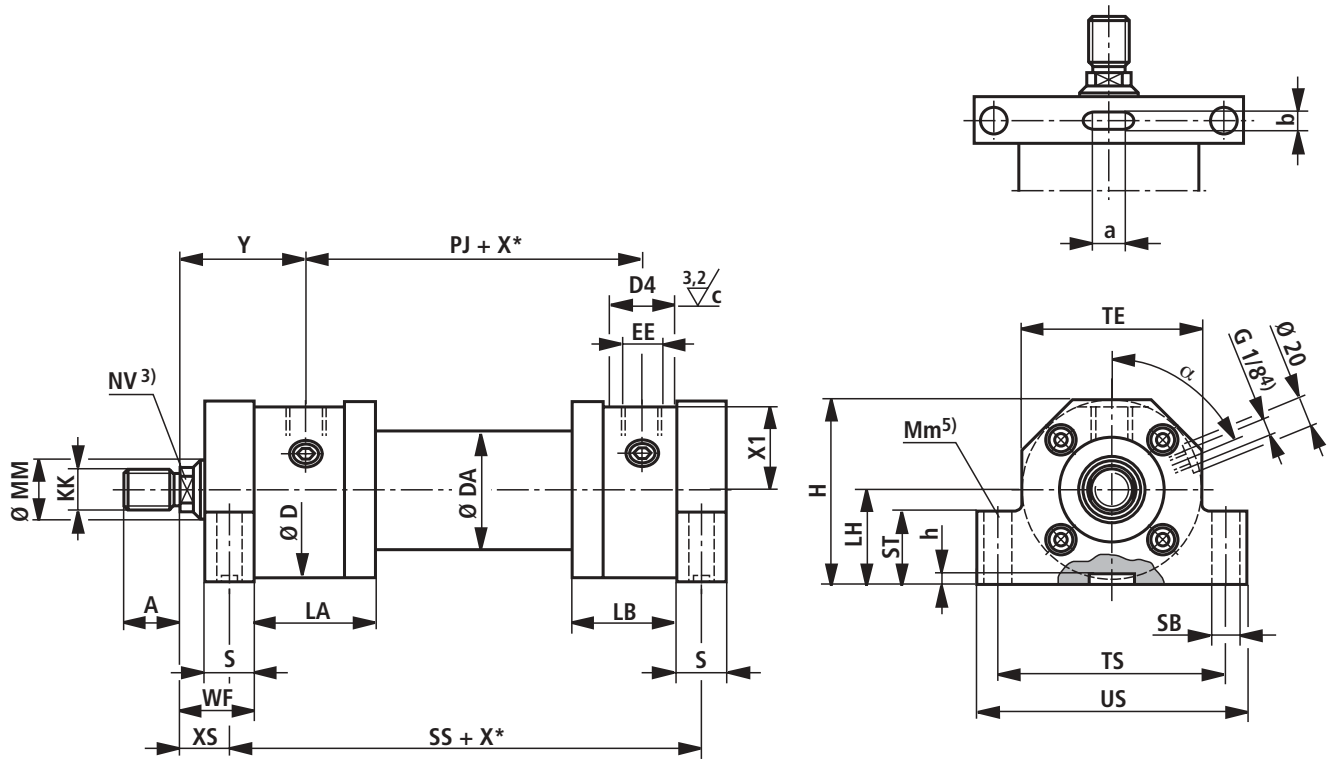

Dimensions MS2 (in mm)

AL Ø	MM Ø	KK ¹⁾ ISO 6020/1	A ¹⁾	KK ²⁾ VW 39 D920	A ²⁾	NV ³⁾	D max.	DA max.	D4	EE	Y	PJ	X1	VE	WF
25	14 18	M12x1.25 M14x1.5	16 18	– M12x1.25	– 16	12 14	56	33	25	G1/4	58	77	25.5	15	28
32	18 22	M14x1.5 M16x1.5	18 22	– M14x1.5	– 18	14 17	67	41	28	G3/8	64	89	30	19	32
40	22 28	M16x1.5 M20x1.5	22 28	– M16x1.5	– 22	17 22	78	52	34	G1/2	71	97	35	19	32
50	28 36	M20x1.5 M27x2	28 36	– M20x1.5	– 28	22 28	95	62	34	G1/2	72	111	44	24	38
63	36 45	M27x2 M33x2	36 45	– M27x2	– 36	28 36	116	77	42	G3/4	82	117	54	29	45
80	45 56	M33x2 M42x2	45 56	– M33x2	– 45	36 46	130	98	42	G3/4	91	134	62	36	54
100	56 70	M42x2 M48x2	56 63	– M42x2	– 56	46 60	158	122	47	G1	108	162	75	37	57
125	70 90	M48x2 M64x3	63 85	– M48x2	– 63	60 75	192	152	47	G1	121	174	92	37	60
160	90 110	M64x3 M80x3	85 95	– M64x3	– 85	75 90	238	193	58	G11/4	143	191	115	41	66
200	110 140	M80x3 M100x3	95 112	– M80x3	– 95	90 120	285	240	58	G11/4	190	224	138	45	75

AL Ø	MM Ø	XS ±2	SS ±2	a	b D10	h	H max.	LH h10	S	SB H13	ST max.	TE	TS js13	US max.	α	LA ±1	LB ±1	Mm ⁵⁾ Nm
25	14/18	18	142	12	6	3.5	60	32	20	9	32	56	75	92	90°	59	44	24
32	18/22	19.5	163	17	8	4	72	38	25	11	38	67	90	110	90°	65	50	45
40	22/28	19.5	183	17	8	4	82	43	25	11	43	78	100	120	67°	75	58	45
50	28/36	22	199	20	10	4.5	100	52	32	13.5	52	95	120	145	67°	74	62	80
63	36/45	29	211	20	10	4.5	120	62	32	17.5	62	116	150	180	67°	82	70	195
80	45/56	34	236	28	14	5	135	70	40	22	70	130	170	210	45°	89	77	385
100	56/70	32	293	34	16	6	161	82	50	26	82	158	205	250	45°	114	93	660
125	70/90	32	321	37	18	6	196	100	56	33	100	192	245	300	45°	127	96	1300
160	90/110	36	364	78	22	8	238	119	60	33	119	238	295	350	38°	155	114	1300
200	110/140	39	447	122	28	9	288	145	72	39	145	285	350	415	38°	209	130	2280

Notes

AL = Piston Ø

MM = Piston rod Ø

X* = Stroke length

1) = Thread version **G**
(to ISO 6020/1)

2) = Thread version **H**
(VW standard VW 39 D 920)

3) = Square or hexagon spanner flats

4) = Bleeding/measuring connection is plugged

5) = The fixing screws must not be subjected to shear loads. The fixing screws (tensile strength class 8.8) are to be tightened to the stated tightening torque M_m .

A thrust key must be provided at the head or base if the calculated frictional forces are lower than the maximum cylinder force.

Flange connections

CDM1: AL-Ø 50-200 mm

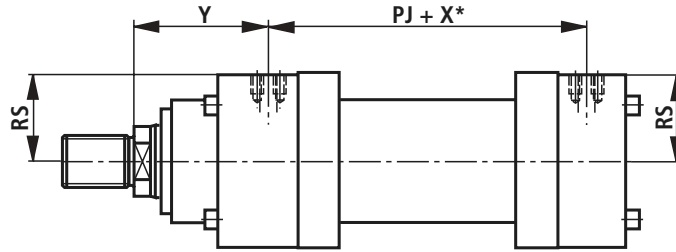

Porting pattern for rectangular flanges to ISO 6162 table 3 (Δ SAE 3000 PSI)

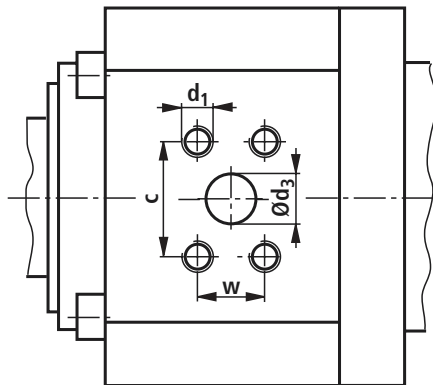

Flange connections

Dimensions (in mm)

AL Ø	ISO 6162 Tab.3 (315 bar) (Δ SAE 3000 PSI)								
	Nom. size	Y	PJ	RS	d ₃ Ø	c	w	d ₁	t ₁ ¹⁾
50	DN13	72	111	39	12.5	38.1	17.5	M8	15
63	DN13	82	117	51	12.5	38.1	17.5	M8	15
80	DN13	91	134	59	12.5	38.1	17.5	M8	15
100	DN19	108	162	72	19	47.6	22.3	M10	17
125	DN19	121	174	90	19	47.6	22.3	M10	17
160	DN25	143	191	114	25	52.4	26.2	M10	17
200	DN25	190	224	138	25	52.4	26.2	M10	17

Notes

For main dimensions see pages 6 to 17

AL = Piston Ø

X* = Stroke length

¹⁾ = Thread depth

Oil drain connection

CDM1: AL-Ø 50-200 mm

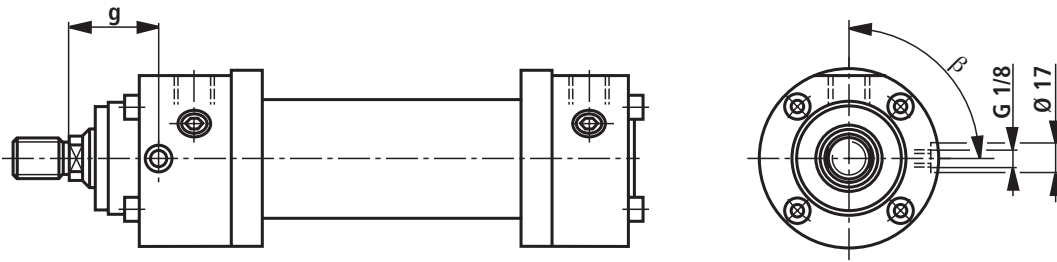

Ø AL	50	63	80	100	125	160	200
β	90°	90°	45°	45°	45°	38°	38°
g	48	55	66	72	80	86	95

Note

AL = Piston Ø

Test point

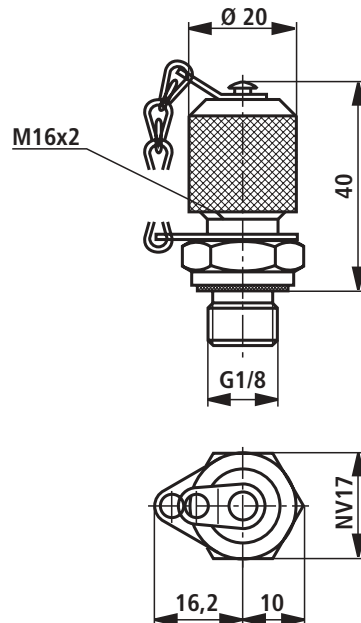

Notes

For pressure measurement or bleeding.

For installation in the bleed/measuring port. Test point with check valve function, i.e. the measurement equipment can be connected even when the system is pressurised.

Scope of supply: Test point made of cadmium plated steel with a synthetic elastomer seal ring.

Order No. 3000-04-005-1

Potentiometer (option P)

CDM1 M00; MF1; MF3; MT4

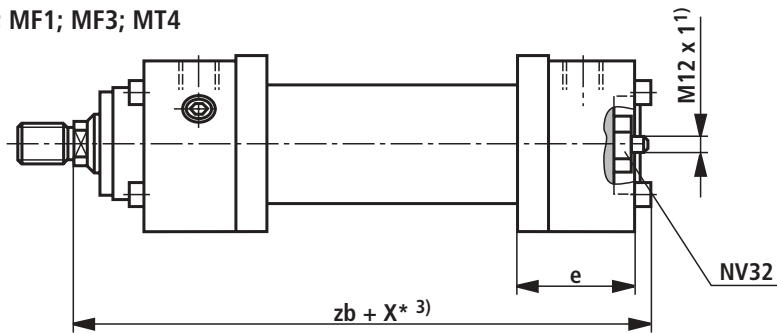

CDM1 MP5

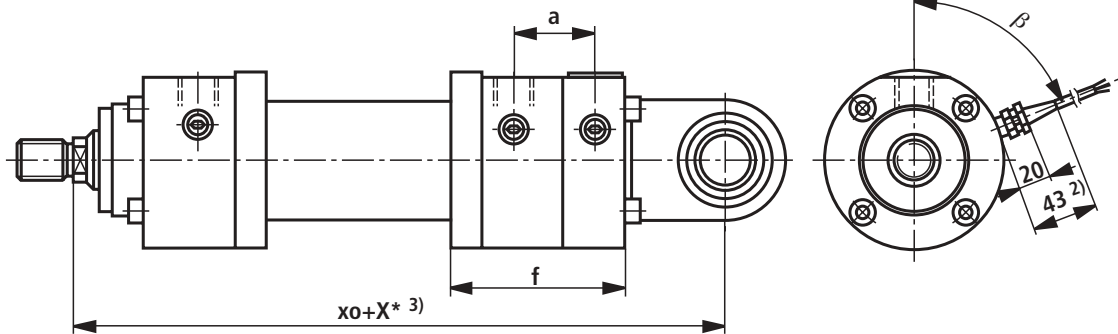

AL Ø	MM Ø	a	β	zb	xo	e	f
40	22 28	59	0°	208	281	68	108
50	28 36	50	67°	222	307	71	112
63	36 45	55	67°	242	344	78	125
80	45 56	60	45°	271	392	88	137
100	56 70	65	45°	315	460	98	158

Notes

For main dimensions, see pages 6 to 15

AL = Piston Ø

MM = Piston rod Ø

X* = Stroke length

1) = The potentiometer has a 4-pin M12 x 1 male sensor type connector, with the following pin allocation:



Electrical connection:

The supply voltage is connected to pins 1 and 4 (brown and black leads).

The output signal is transmitted via pins 3 and 4 (blue and black leads). The colour marking is valid for cable to Order No. 440-715-000-1, page 37 or the cable mounting MP5.

2) = The minimum recommended cable bending radius of 30 mm has to be added.

3) = Minimum stroke length = 25 mm
Maximum stroke length = 520 mm

Technical data: potentiometer (option P)

For general technical data see page 2.

Technical data: potentiometer

Continuous position sensing along the entire stroke length. End position cushioning is not possible.

Dimensions:

The installation dimensions that deviate from pages 6 to 15 are given in the dimensional drawings on page 20.

Hydraulic fluid:

Only mineral oil is permissible - DIN 51 524 (HL, HLP).

Stroke velocity:

Speed range	Viscosity range
0 - 0.5 m/s	10 - 300 mm ² /s
0 - 0.3 m/s	10 - 500 mm ² /s

Transducer:

The potentiometer functions as a voltage divider. Position is thus given as a voltage ΔU which is proportionally related to the stroke X of the cylinder from the supply voltage U .

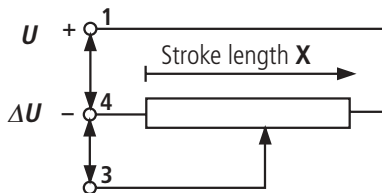

Non-linearity:

< 0.1% of the electrical stroke.

Resistance:

90 Ω/mm ± 20%

Insulation resistance:

1 000 MΩ

Max. load current:

1 mA

Recommended load resistance:

> 10 MΩ

Resolution infinity:

Unendlich

Max. supply voltage, U:

30 V DC

Operating temperature: -20 °C to +80 °C

Service life, transducer:

100 x 10⁶

Connection/plug:

Plug M12 x 1, 4-pin plug (sensor).

Connection/cable:

Cylinders with mounting element MP5 are supplied fitted with a screened, 3 conductor cable, 5 m long, mineral oil resistant.

Brown lead	-	Bush 1
Blue lead	-	Bush 3
Black lead	-	Bush 4

The screen is not connected in the plug.

Proximity switches (option E)

CDM1

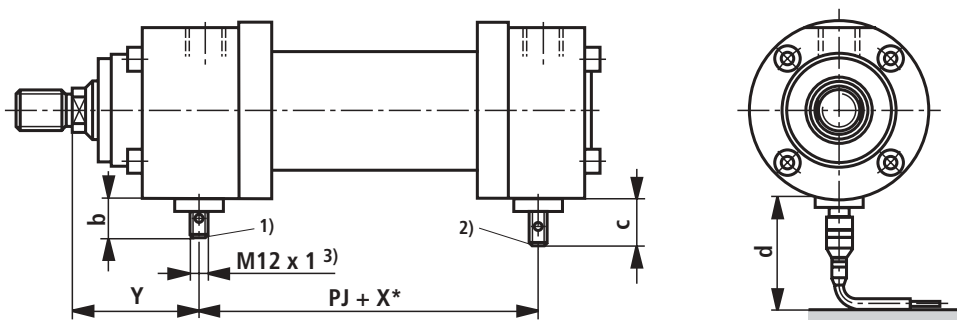

Dimensions: option E (in mm)

AL Ø	MM Ø	b ⁴⁾ ±0.5	c ⁴⁾ ±0.5	d ⁵⁾ min	Y	PJ
40	22 28	33 36	36 36	105	64	104
50	28 36	27.5 31.5	31.5 31.5	100	69	111
63	36 45	21 25.5	25.5 25.5	95	78	118
80	45 56	18.5 24	24 24	94	88	132
100	56 70	10.5 17.5	17.5 17.5	88	110	150
125	70 90	0 10	10 10	80	124	163
160	90 110	-13 -3	-3 -3	67	142	181
200	110 140	-26.5 -11.5	-11.5 -11.5	60	189	210

Notes

For main dimensions, see pages 6 to 15

AL = Piston Ø

MM = Piston rod Ø

X* = Stroke length

1) = **Electrical connection, head sensor:**

The supply voltage is connected to pin 1 (+) and pin 3 (-).
The closing output signal is obtained from pin 2 when the cylinder is approaching its head end.

2) = **Electrical connection, base sensor:**

The supply voltage is connected to pin 1 (+) and pin 3 (-).
The closing output signal is obtained from pin 4 when the cylinder is approaching its base end.

3) = The sensors have a 4-pin M12x1 plug with the following pin allocation:

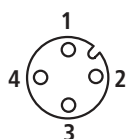

(view of pin side)

4) = The sensors are factory mounted to the correct depth in order to guarantee the output signal.

Dimensions **b** and **c** can be negative, as the sensor is below the end cover surface.

Note: Never change the installation depth of the sensor as this can either destroy the sensor or cause the output signal to be lost.

5) = **d** is the recommended minimum dimension when using cable with Order No. 440-815-833-1.

Technical data: proximity switches (option E)

For the technical data, see page 2.

Technical data: proximity switches

End position sensing, head and base end position, giving an output signal typically 1 to 3 mm before the end of the stroke.

Dimensions:

The installation dimensions that deviate from pages 6 to 15 are given in the dimensional drawings on page 22.

Proximity sensors (2 per cylinder):

The sensors are pressure-proof inductive sensors, with double outputs PNP: NC (pin 2) and NO (pin 4). They are fitted into the end covers with a special sealing and locking device that allows the sensor to be used in all cylinder sizes, without adaptors.

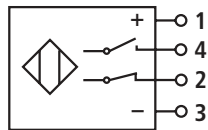

Nominal sensing distance:

1.5 mm

Supply voltage:

24 V DC (10 - 30 V DC) with a max. residual ripple of < 10 %.

Electrical protection:

The sensor is protected against short circuit, polarity error and excess voltage.

Max. load current:

150 mA

Max. leakage current:

50 μ A

Current consumption:

< 17 mA

Active pull down resistor:

4.7 k Ω

Voltage drop over a closed switch:

< 1.2 V

Protection type:

IP 67 only in conjunction with cable 440-815-833-1.

Operating temperature: -20 °C to +80 °C

Plug:

Plug M12 x 1, 4-pin plug (sensor).

Cable for the potentiometer and proximity switch

Cable for the potentiometer

The cable is mineral oil resistant and with a protection of IP 67.

Order No. 440-715-000-1

Brown lead – Bush 1

Blue lead – Bush 3

Black lead – Bush 4

The screen is not connected in the plug.

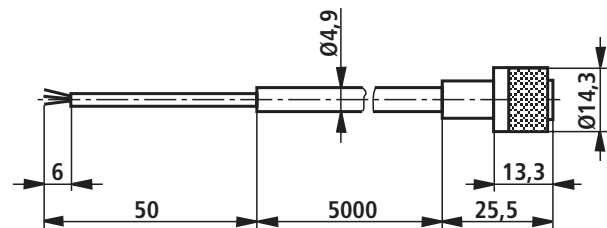
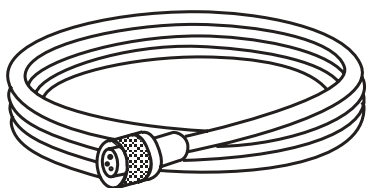

Cable for the proximity switch

The cable is mineral oil resistant and with a protection to IP 67.

Order No. 440-815-833-1

Brown lead – Bush 1

White lead – Bush 2

Blue lead – Bush 3

Black lead – Bush 4

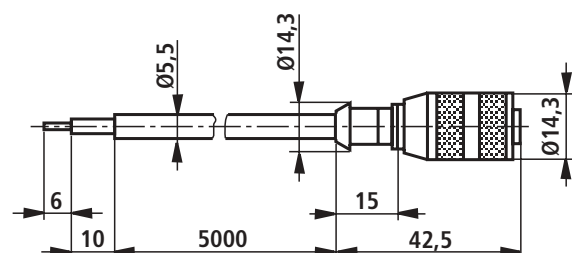
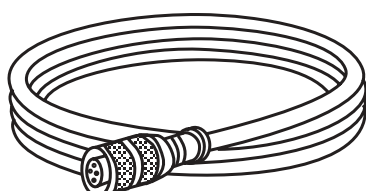

Self-aligning clevis (dimensions in mm)

ISO 6982
DIN 24 338

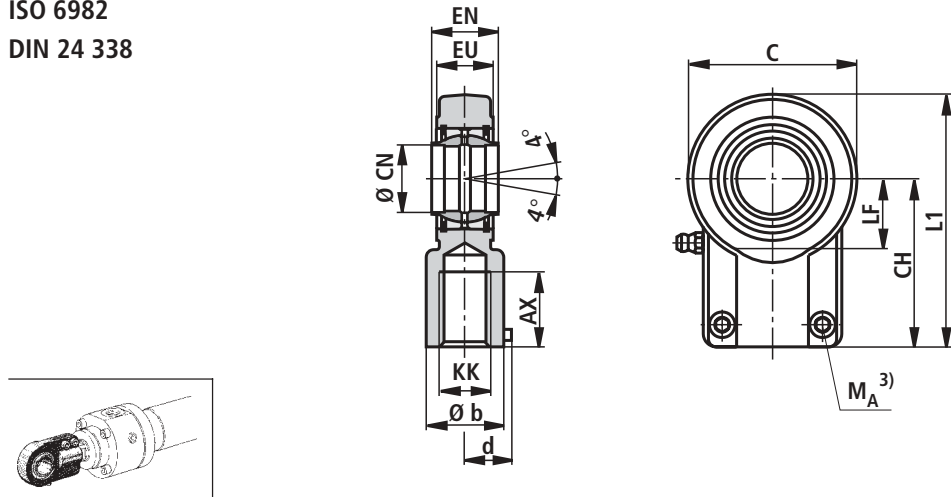

AL Ø	MM Ø	Order No.	KK	AX min.	b	C	CH js16	CN H7	d max.	EN h12	EU	L1 max.	LF	$M_A^{3)}$ Nm	$m^{4)}$ kg
25	14 ¹⁾ /18 ²⁾	371-25-0002-1	M12x1.25	17	16	32	38	12	11.5	12	10.5	54	14	8	0.1
25 32	18 ¹⁾ 18 ¹⁾ /22 ²⁾	371-32-0002-1	M14x1.5	19	21	40	44	16	14.5	16	13	64	18	13	0.2
32 40	22 ¹⁾ 22 ¹⁾ /28 ²⁾	371-40-0002-1	M16x1.5	23	25	50	52	20	18.5	20	17	77	22	32	0.4
40 50	28 ¹⁾ 28 ¹⁾ /36 ²⁾	371-50-0002-1	M20x1.5	29	30	62	65	25	18.5	25	21	97	27	32	0.7
50 63	36 ¹⁾ 36 ¹⁾ /45 ²⁾	371-63-0002-1	M27x2	37	38	76	80	32	22	32	27	120	32	64	1.1
63 80	45 ¹⁾ 45 ¹⁾ /56 ²⁾	371-80-0002-1	M33x2	46	47	97	97	40	26	40	32	147	41	64	2.1
80 100	56 ¹⁾ 56 ¹⁾ /70 ²⁾	371-98-0002-1	M42x2	57	58	118	120	50	29	50	40	183	50	110	4.5
100 125	70 ¹⁾ 70 ¹⁾ /90 ²⁾	371-12-0002-1	M48x2	64	70	142	140	63	37	63	52	211	62	80	7.6
125 160	90 ¹⁾ 90 ¹⁾ /110 ²⁾	371-16-0002-1	M64x3	86	90	180	180	80	46	80	66	270	78	195	15
160 200	110 ¹⁾ 110 ¹⁾ /140 ²⁾	371-20-0002-1	M80x3	96	110	224	210	100	57	100	84	322	98	385	28
200	140 ¹⁾	374-20-0002-1	M100x3	113	135	290	260	125	63	125	102	420	120	385	55

Notes

AL = Piston Ø

MM = Piston rod Ø

¹⁾ = Self-aligning clevis for piston rod end **G**
(ISO 6020/1)

²⁾ = Self-aligning clevis for piston rod end **H**
(VW standard VW 39 D920)

³⁾ = The self-aligning clevis must always be screwed to the piston rod thread stop. Subsequently, the clamping screws have to be tightened to the specified torque.

⁴⁾ = Weight of the self-aligning clevis

Mounting block (in mm)

ISO 8132
CR Ø 12-80

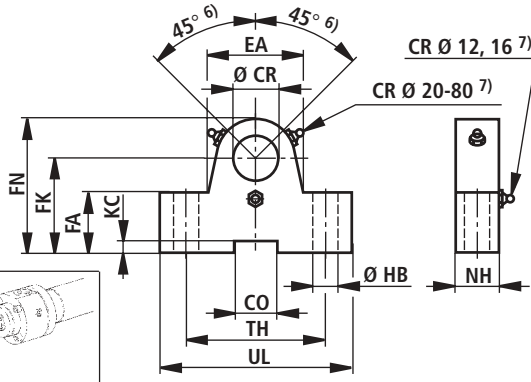
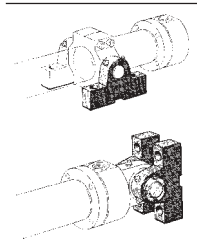

CR Ø 100-125

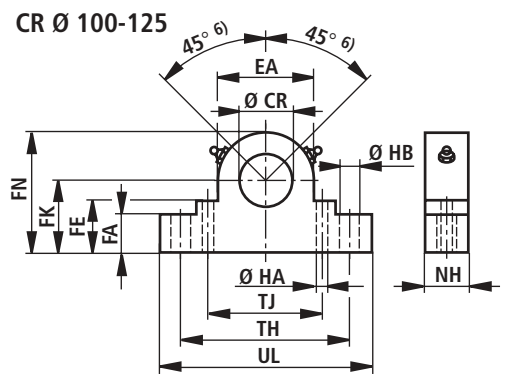

AL Ø	MM Ø	AL Ø	MM Ø	Order No.	CO N9	CR G7.	EA max.	FA	FE	FK JS12	FN	HA	HB	KC +0.3 0	NH	TJ Nm	TH kg	UL	m ⁵⁾
25	14/18	25	14 ¹⁾ /18 ²⁾	371-25-0012-1	10	12	20	20	-	34	45	-	9	3.3	16	-	40	60	0.4
32	18/22	25 32	18 ¹⁾ / 22 ²⁾	371-32-0012-1	16	16	24	25	-	40	53	-	11	4.3	20	-	50	76	0.6
40	22/28	32 40	22 ¹⁾ / 28 ²⁾	371-40-0012-1	16	20	35	27	-	45	63	-	11	4.3	20	-	60	86	1.0
50	28/36	40 50	28 ¹⁾ / 36 ²⁾	371-50-0012-1	25	25	54	35	-	55	77	-	14	5.4	24	-	80	110	1.8
63	36/45	50 63	36 ¹⁾ / 45 ²⁾	371-63-0012-1	25	32	65	40	-	65	92	-	18	5.4	30	-	110	150	3.4
80	45/56	63 80	45 ¹⁾ / 56 ²⁾	371-80-0012-1	36	40	82	45	-	76	112	-	22	8.4	32	-	125	170	5.0
100	56/70	80 100	56 ¹⁾ / 70 ²⁾	371-98-0012-1	36	50	106	60	-	95	138	-	27	8.4	40	-	160	210	9.6
125	70/90	100 125	70 ¹⁾ / 90 ²⁾	371-12-0012-1	50	63	140	70	-	112	168	-	33	11.4	50	-	200	260	19
160	90/110	125 160	90 ¹⁾ / 110 ²⁾	371-16-0012-1	50	80	175	85	-	140	215	-	39	11.4	62	-	250	322	31
200	110/140	160 200	110 ¹⁾ / 140 ²⁾	371-20-0012-1	-	100	180	80	110	160	250	24.8 ³⁾	39	-	80	214	324	394	65
-	-	200	140 ¹⁾	374-20-0012-1	-	125	224	90	120	170	282	29.8 ⁴⁾	42	-	100	264	394	490	98

Notes

The mounting blocks are suitable for use with the mounting styles MP5, MT4 and self-aligning clevis (max. pivot angle ± 45°).
Mounting blocks are always supplied in pairs.

¹⁾ = In combination with self-aligning clevis for piston rod end **G**.
(ISO 6020/1)

²⁾ = In combination with a self-aligning clevis for piston rod end **H**.
(VW standard VW 39 D 920)

³⁾ = Dowel pins Ø 25 m6 x 150 mm are included within the scope of supply.

⁴⁾ = Dowel pins Ø 30 m6 x 150 mm are included within the scope of supply.

⁵⁾ = Weight of the mounting block (weight per pair)

⁶⁾ = Max. cylinder swivel angle

⁷⁾ = Grease nipple position

Pins (in mm)

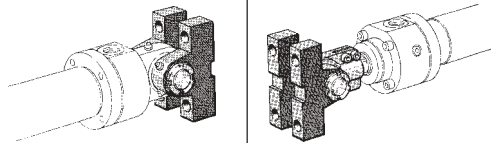

AL Ø	MM Ø	AL Ø	MM Ø	Order No.	EL	EK j6	UA	m ³⁾ kg
25	14/18	25	14 ¹⁾ /18 ²⁾	371-25-0013-1	44	12	55	0.1
32	18/22	25 32	18 ¹⁾ / 22 ²⁾	371-32-0013-1	56	16	69	0.1
40	22/28	32 40	22 ¹⁾ / 28 ²⁾	371-40-0013-1	60	20	75	0.2
50	28/36	40 50	28 ¹⁾ / 36 ²⁾	371-50-0013-1	73	25	90	0.4
63	36/45	50 63	36 ¹⁾ / 45 ²⁾	371-63-0013-1	92	32	110	0.8
80	45/56	63 80	45 ¹⁾ / 56 ²⁾	371-80-0013-1	104	40	124	1.3
100	56/70	80 100	56 ¹⁾ / 70 ²⁾	371-98-0013-1	130	50	154	2.5
125	70/90	100 125	70 ¹⁾ / 90 ²⁾	371-12-0013-1	163	63	190	5
160	90/110	125 160	90 ¹⁾ / 110 ²⁾	371-16-0013-1	204	80	240	10
200	110/140	160 200	110 ¹⁾ / 140 ²⁾	371-20-0013-1	260	100	304	20
-	-	200	140 ¹⁾	374-20-0013-1	325	125	375	38

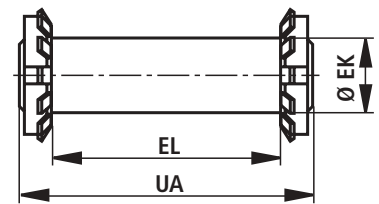

Notes

Pins are suitable for combination with mounting style MP5 and self-aligning clevis.

AL = Piston Ø

MM = Piston rod Ø

¹⁾ = In combination with a self-aligning clevis for piston rod end **G**.
(ISO 6020/1)

²⁾ = In combination with a self-aligning clevis for piston rod end **H**.
(VW standard VW 39 D920)

³⁾ = Weight of pins

Buckling

The permissible stroke with a flexibly guided load and a 3.5 factor of safety against buckling can be obtained from the relevant table. For deviating cylinder installation positions, the permissible stroke length has to be interpolated. Permissible strokes for non-guided loads on request.

Calculations for buckling are carried out using the following formulas:

1. Calculation according to Euler

$$F = \frac{\pi^2 \cdot E \cdot I}{\nu \cdot L_K^2} \quad \text{if } \lambda > \lambda_g$$

2. Calculation according to Tetmajer

$$F = \frac{d^2 \cdot \pi (335 - 0,62 \cdot \lambda)}{4 \cdot \nu} \quad \text{if } \lambda \leq \lambda_g$$

Influence of the mounting type on the buckling length:

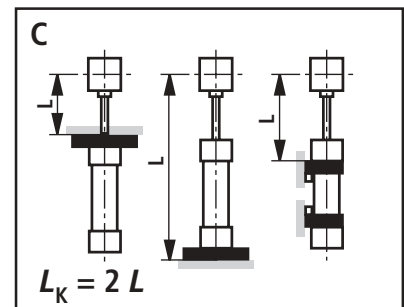
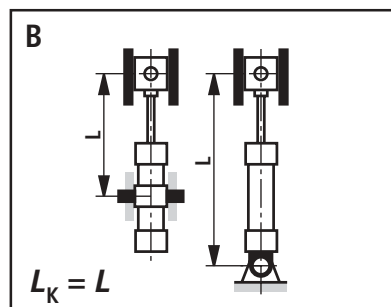
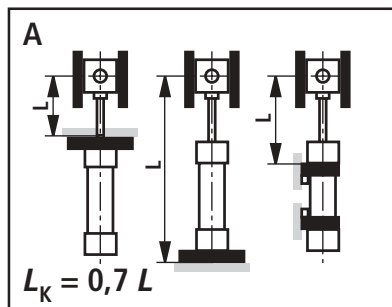

Explanation:

E = Modulus of elasticity in N/mm²
= 2.1×10^5 for steel

I = Moment of inertia in mm⁴ for a circular cross-section
 $= \frac{d^4 \cdot \pi}{64} = 0.0491 \cdot d^4$

ν = 3.5 (safety factor)

L_K = Free buckling length in mm (dependent on the mounting styles, see sketches A, B, C)

d = Piston rod \varnothing in mm

λ = Slenderness ratio
 $= \frac{4 \cdot L_K}{d} \quad \lambda_g = \pi \sqrt{\frac{E}{0.8 \cdot R_e}}$

R_e = Yield strength of the piston rod material

Permissible stroke lengths (in mm)

Mounting styles MF2, MF4, MT4 centre trunnion

AL \varnothing	MM \varnothing	Permissible stroke at									Max. available stroke
		70 bar			100 bar			160 bar			
		0°	45°	90°	0°	45°	90°	0°	45°	90°	
25	14 18	260 435	270 455	305 485	215 385	220 400	240 460	160 310	165 315	170 340	600
32	18 22	340 510	355 535	410 665	290 450	295 465	325 535	215 365	220 370	230 400	800
40	22 28	405 640	425 680	495 875	345 575	355 600	395 710	265 475	270 490	285 535	1000
50	28 36	540 845	560 895	665 1180	465 765	480 805	535 970	365 645	370 665	390 735	1200
63	36 45	705 1030	740 1100	900 1480	620 945	640 990	725 1220	500 805	510 830	540 930	1400
80	45 56	855 1230	900 1310	1120 1700	760 1130	790 1190	905 1490	615 975	630 1010	680 1140	1700
100	56 70	1030 1500	1090 1590	1390 2000	925 1380	965 1460	1130 1880	760 1200	780 1250	850 1440	2000
125	70 90	1280 1900	1360 2030	1770 2300	1160 1770	1210 1880	1450 2300	970 1570	995 1640	1090 1950	2300
160	90 110	1620 2200	1710 2350	2320 2600	1470 2060	1540 2180	1900 2600	1250 1820	1290 1900	1440 2280	2600
200	110 140	1890 2720	2010 2910	2760 3000	1730 2560	1820 2720	2260 3000	1470 2290	1520 2400	1720 2980	3000

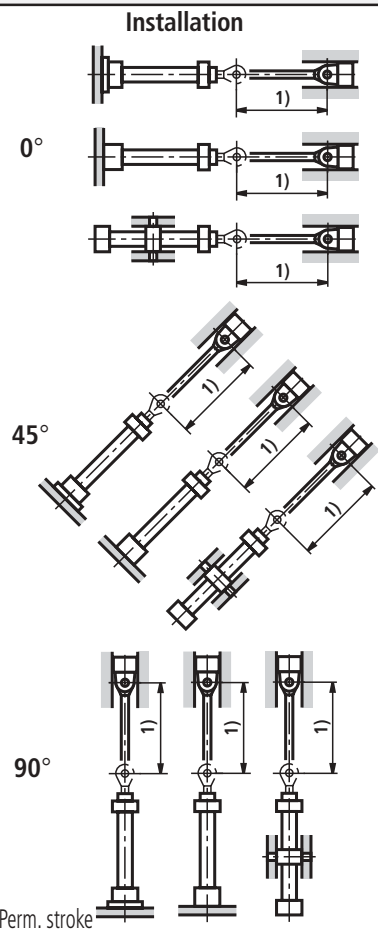

Permissible stroke lengths (in mm)

Mounting styles: MF1, MF3, MS2

AL Ø	MM Ø	Permissible stroke at									Max. available stroke	Installation	
		70 bar			100 bar			160 bar					
		0°	45°	90°	0°	45°	90°	0°	45°	90°			
25	14	350	355	380	300	305	315	235	240	245	600		
	18	530	550	645	470	485	535	390	400	415			
32	18	445	455	495	385	390	410	310	315	320			800
	22	615	640	660	550	570	625	460	465	490			
40	22	530	545	590	460	470	490	370	375	380			1000
	28	775	810	980	700	725	815	590	600	635			
50	28	670	690	770	590	600	640	475	485	495			1200
	36	975	1020	1300	890	925	1080	765	785	845			
63	36	845	880	1000	750	770	830	615	625	645			1400
	45	1170	1230	1400	1070	1120	1330	920	950	1040			
80	45	1020	1060	1240	910	935	1020	750	765	795	1700		
	56	1390	1470	1700	1280	1340	1620	1110	1150	1270			
100	56	1240	1290	1540	1110	1150	1280	930	940	990	2000		
	70	1680	1780	2000	1560	1640	2000	1370	1410	1590			
125	70	1510	1570	1920	1360	1400	1590	1140	1160	1240	2300		
	90	2090	2220	2300	1960	2060	2300	1740	1810	2110			
160	90	1880	1980	2500	1720	1780	2070	1460	1500	1610	2600		
	110	2430	2580	2600	2280	2400	2600	2030	2110	2460			
200	110	2210	2320	2980	2020	2100	2470	1730	1770	1920	3000		
	140	2980	3000	3000	2810	2980	3000	2540	2650	3000			

Mounting styles: MP3, MP5

AL Ø	MM Ø	Permissible stroke at									Max. available stroke	Installation	
		70 bar			100 bar			160 bar					
		0°	45°	90°	0°	45°	90°	0°	45°	90°			
25	14	155	160	175	120	125	130	75	80	85	600		
	18	300	310	360	250	260	285	190	195	200			
32	18	210	220	240	165	170	180	110	115	120			800
	22	345	360	420	290	300	330	220	225	235			
40	22	255	265	295	205	210	225	140	145	150			1000
	28	445	465	560	385	395	445	295	305	320			
50	28	350	360	405	285	290	315	205	210	215			1200
	36	600	630	770	525	540	615	415	425	455			
63	36	470	490	560	395	405	440	290	295	310			1400
	45	740	780	970	650	680	780	525	535	580			
80	45	575	600	700	490	505	555	370	375	390	1700		
	56	890	935	1190	790	820	960	640	660	715			
100	56	705	735	880	600	620	695	460	470	495	2000		
	70	1085	1150	1500	970	1015	1215	800	825	910			
125	70	890	935	1135	770	800	905	605	615	655	2300		
	90	1400	1490	2030	1270	1340	1660	1070	1110	1250			
160	90	1130	1190	1490	990	1030	1190	790	810	870	2600		
	110	1620	1720	2370	1470	1550	1930	1240	1290	1450			
200	110	1320	1390	1770	1160	1210	1420	930	955	1040	3000		
	140	2010	2140	3000	1850	1950	2520	1580	1650	1910			

Self regulating end position cushioning

The objective is to reduce the speed of a moving mass, whose centre of gravity for the calculation lies on the cylinder axis, to a level, at which neither the cylinder nor the machine, into which the cylinder is installed, can be damaged.

The self adjusting end position cushioning produces a controlled deceleration in both end positions (braking). The effective cushioning length adjusts automatically to the actual requirements.

Each cylinder that is fitted with end position cushioning must utilise its entire stroke length so that the optimum cushioning can be achieved.

The advantages of our damping system are:

- Progressive delay
- Short damping times
- No pressure peaks, therefore increased safety and service life

Notes on the cushioning capacity

The calculation depends on the factors of weight, velocity, system pressure and installation orientation. Therefore, the variable D_m is to be calculated from the weight and the speed, the variable D_p from the system pressure and installation orientation. These variables are then used to verify the permissible cushioning performance in the "cushioning capacity" diagram. The intersection point of the variables D_m and D_p must always be below the cushioning capacity curve of the selected cylinder.

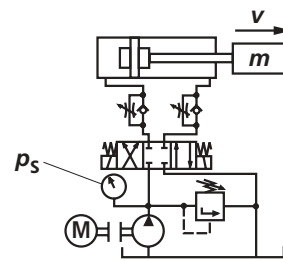

Formulas:

$$D_m = \frac{m}{10^K} ; \quad K = kv (0,5-v)$$

m = Moved weight in kg
 v = Stroke velocity in m/s
 kv = See page 29

Extending:

$$D_p = p_s - \frac{m \cdot 9,81 \cdot \sin \alpha}{A_1 \cdot 10}$$

Retracting:

$$D_p = p_s + \frac{m \cdot 9,81 \cdot \sin \alpha}{A_3 \cdot 10}$$

p_s = System pressure in bar
 A_1 = Piston area in cm^2 (see page 2)
 A_3 = Annulus area in cm^2 (see page 2)
 α = Angle in degrees with reference to the horizontal plane

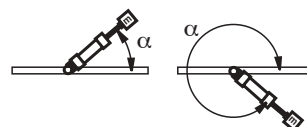
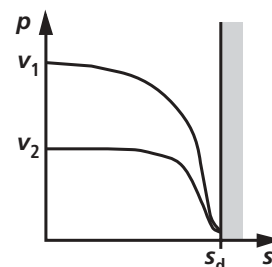
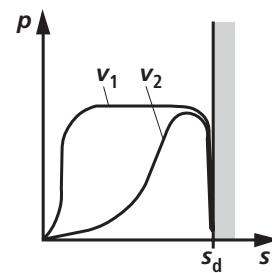

End position cushioning / cushioning capacity

AL/MM Ø mm	25	32	40	50	63	80	100	125	160	200
kv ①	2.97	2.56	2.82	3.51	3.02	2.53	2.65	2.91	2.76	2.95
kv ②	3.15	2.93	2.95	3.45	2.95	2.53	2.93	2.95	2.95	3.1
kv ③	3.1	2.73	3.1	3.51	2.95	2.51	2.91	2.95	2.91	2.93

Cushioning capacity: extending

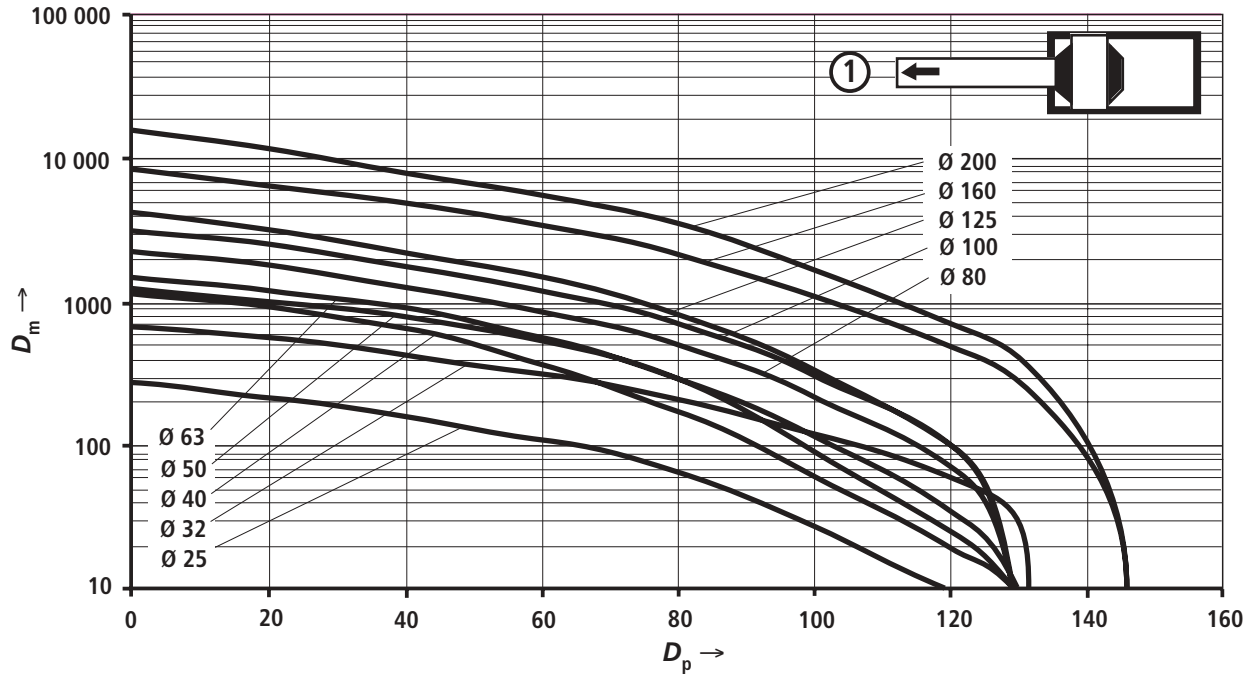

Cushioning capacity: retracting

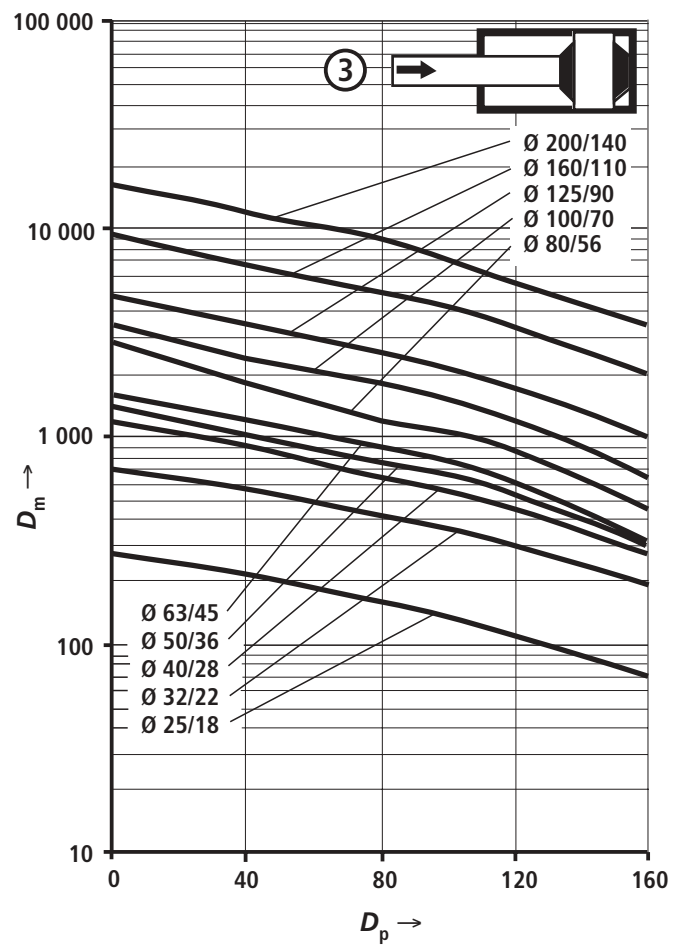
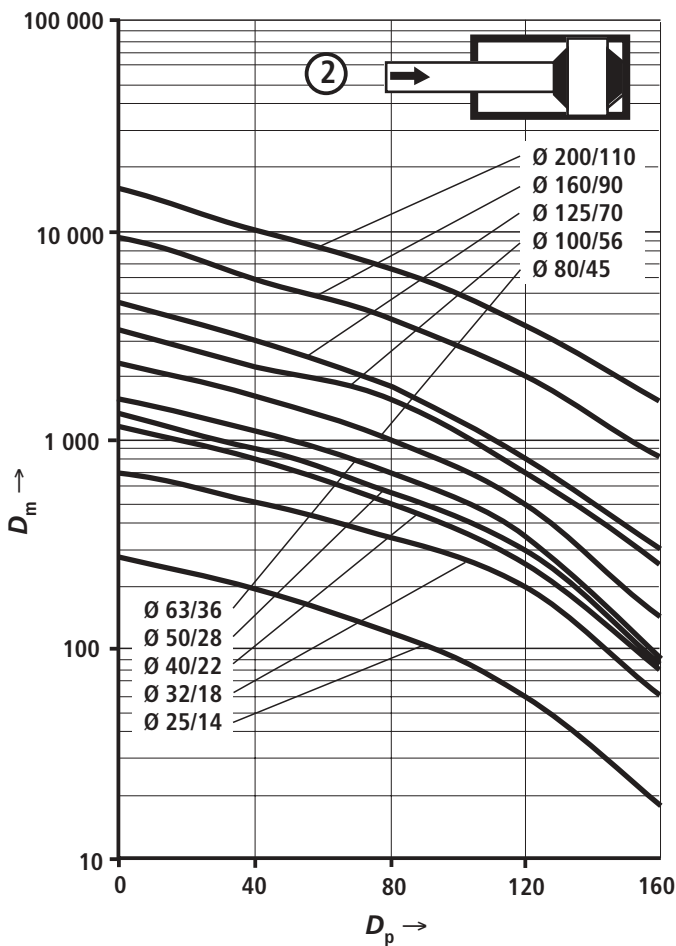

CDM1

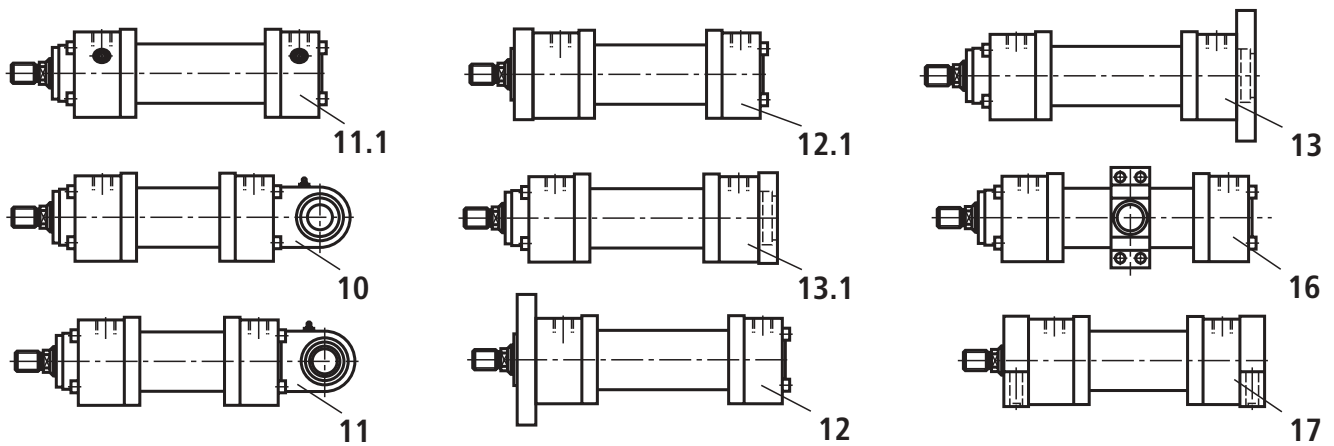
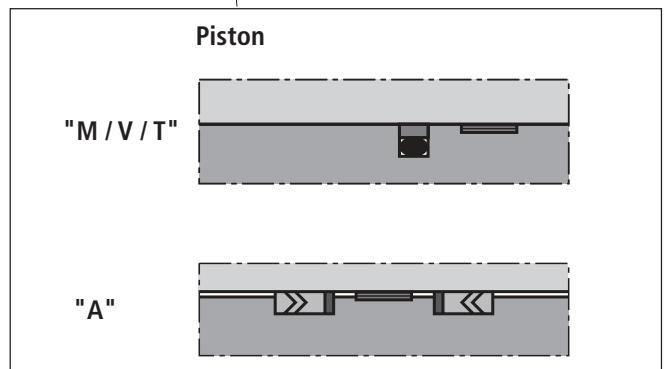
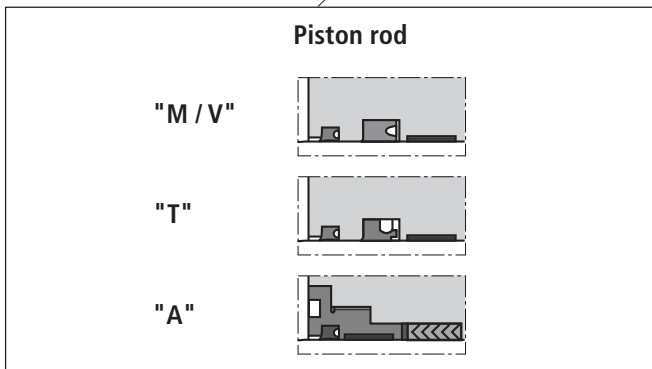
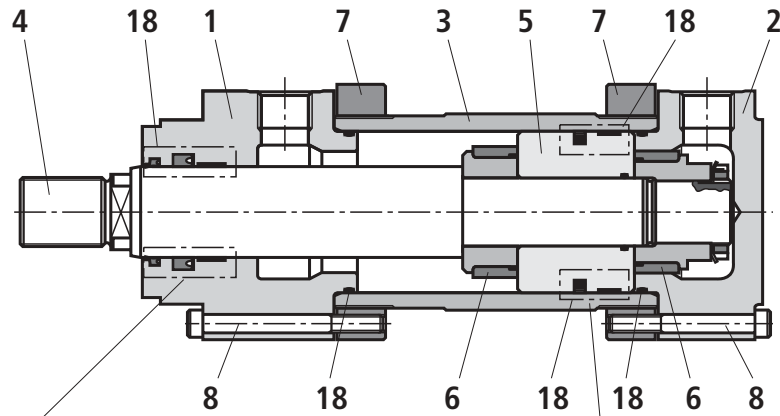

- | | | | | | |
|---|-----------------|-------|------------------------|-------|---|
| 1 | Head | 8 | S.H.C.S. | 13 .1 | Rectangular flange MF2 |
| 2 | Base | 10 | Base MP3 | 16 | Trunnion MT4 |
| 3 | Barrel | 11 | base MP5 | 17 | Foot MS2 |
| 4 | Piston rod | 11 .1 | Basic version M00 | 18 | Seal kit:
Wiper, rod seal,
piston seal, O-ring,
back-up ring, guide bush |
| 5 | Piston | 12 | Round flange MF3 | | |
| 6 | Cushioning bush | 12 .1 | Rectangular flange MF1 | | |
| 7 | Flange | 13 | Round flange MF4 | | |

Tightening torque

Screws: head and base (Pos. 1 and 2)

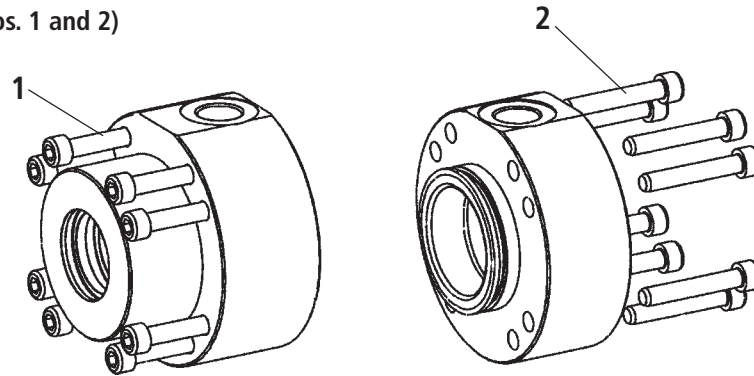

Piston Ø	Screw	Quantity	Grade	Tightening torque
25	M6	4	12.9	15 Nm
32	M6	4	12.9	15 Nm
40	M6	4	12.9	15 Nm
50	M8	4	12.9	37 Nm
63	M10	4	12.9	73 Nm
80	M8	8	12.9	37 Nm
100	M10	8	12.9	73 Nm
125	M12	8	12.9	128 Nm
160	M12	12	12.9	128 Nm
200	M16	12	12.9	320 Nm

Seal kits

CDM1 – Standard

AL Ø	MM Ø	Material No. Seal versions			
		M	T	A	V
25	14	04906-226-08	–	–	049-062-910-6
	18	04906-227-05	–	–	049-063-030-3
32	18	04906-228-02	–	–	049-062-920-3
	22	04906-229-18	–	–	049-063-110-1
40	22	04906-230-00	–	–	049-062-930-0
	28	04906-231-08	–	–	049-063-120-9
50	28	04906-232-05	–	049-063-040-0	049-062-940-8
	36	04906-233-02	049-063-340-9	049-063-270-8	049-063-130-6
63	36	04906-234-18	049-063-150-0	049-063-050-8	049-062-950-5
	45	04906-235-07	049-063-350-6	049-063-280-5	049-063-210-4
80	45	04906-236-04	049-063-160-8	049-063-060-5	049-062-960-2
	56	04906-237-01	049-063-360-3	049-063-290-2	049-063-220-1
100	56	04906-238-09	049-063-170-5	049-063-070-2	049-062-971-8
	70	04906-239-06	049-063-370-0	049-063-301-8	049-063-230-9
125	70	04906-240-07	049-063-180-2	049-063-081-8	049-062-980-7
	90	04906-241-04	049-063-380-8	049-063-310-7	049-063-240-6
160	90	04906-242-01	049-063-191-8	049-063-090-7	049-062-990-4
	110	04906-243-09	049-063-390-5	049-063-320-4	049-063-250-3
200	110	04906-244-06	049-063-200-7	049-063-100-4	049-063-000-1
	140	04906-245-03	049-063-400-2	049-063-330-1	049-063-260-0

The data specified above only serves to describe the product. No statements concerning a certain condition or suitability for a certain application can be derived from our information.

The details stated do not release you from the responsibility for carrying out your own assessment and verification. It must be remembered that our products are subject to a natural process of wear and ageing.

**Bosch Rexroth AG
Industrial Hydraulics**

D-97813 Lohr am Main
Zum Eisengießer 1 • D-97816 Lohr am Main
Telefon 0 93 52 / 18-0
Telefax 0 93 52 / 18-23 58 • Telex 6 89 418-0
eMail documentation@boschrexroth.de
Internet www.boschrexroth.de

Bosch Rexroth SA

BP 37 – Z.I. Les Fourmis
F-74131 Bonneville Cedex
Tel. +33(0)4 50 25 35 45
Fax +33(0)4 50 25 35 19
Internet www.boschrexroth.fr

Bosch Rexroth Teknik AB

Varuvägen 7, Älvsjö
S-125 81 Stockholm
Tel. +46(08) 72 79 20 0
Fax +46(08) 86 87 21
eMail cyl.hyd@boschrexroth.se
Internet www.boschrexroth.se
