

DL3

SOLENOID OPERATED DIRECTIONAL CONTROL VALVE COMPACT VERSION

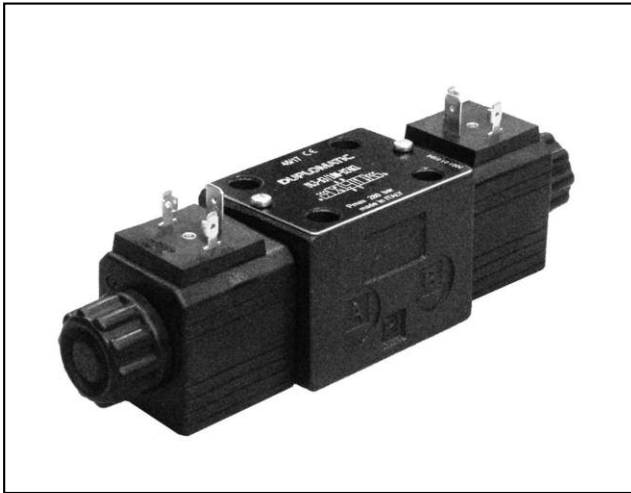

SUBPLATE MOUNTING ISO 4401-03

p max **280** bar
Q max **50** l/min

MOUNTING SURFACE

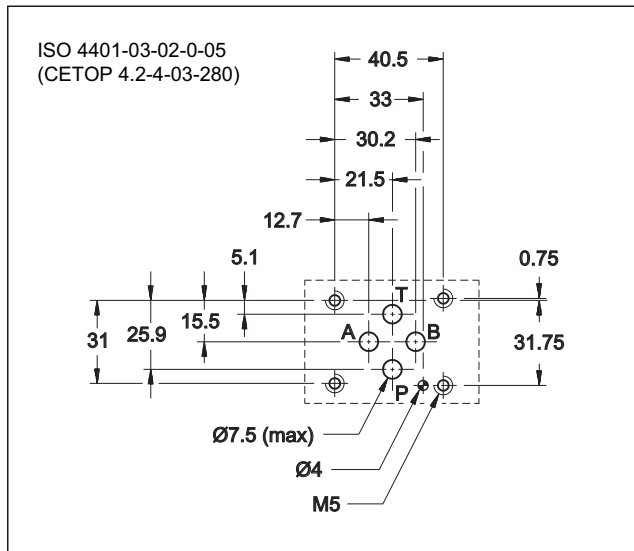

OPERATING PRINCIPLE

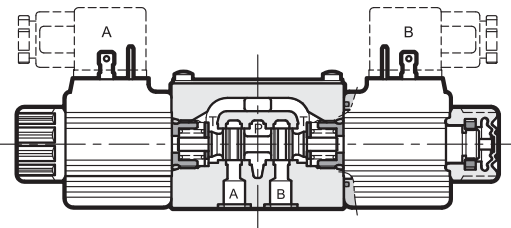

- Direct acting, subplate mounting directional control valve, with mounting surface according to ISO 4401-03 standards.
- Compact design with reduced solenoid dimensions, suitable for mini-power packs and mobile and agricultural applications.
- The valve body is made with high strength iron castings provided with wide internal passages in order to minimize the flow pressure drop. Wet armature solenoids with interchangeable coils are used (for further information on solenoids see paragraph 7).

PERFORMANCES (with mineral oil of viscosity of 36 cSt at 50°C)

	bar	CC	CA
		280 250	160
Maximum operating pressure: - ports P - A - B - port T			
Maximum flow rate	l/min	50	
Pressure drop $\Delta p-Q$		see paragraph 4	
Operating limits		see paragraph 5	
Electrical features		see paragraph 7	
Electrical connections		see paragraph 11	
Ambient temperature range	°C	-20 / +50	
Fluid temperature range	°C	-20 / +80	
Fluid viscosity range	cSt	10 + 400	
Fluid contamination degree		according to ISO 4406:1999 class 20/18/15	
Recommended viscosity	cSt	25	
Masse: single solenoid valve double solenoid valve	kg	1,1 1,4	

- The valve is supplied with 3 or 4 way designs and with several interchangeable spools with different porting arrangements.
- The valve is available with DC or AC current solenoids and with several types of electrical connections to cover various installation requirements (see paragraphs 7 and 11).
- The DC valve comes with boot protected manual override which ensures a protection degree IP69K for connections types WK7 and WK8.
- It is available also with zinc-nickel surface treatment, that ensures a salt spray resistance up to 600 hours.

1 - IDENTIFICATION CODE

	D	L	3	-	/			-		/	
--	----------	----------	----------	---	---	--	--	---	--	---	--

Solenoid operated directional control valve

Compact version

ISO 4401-03 size

Spool type (see paragraph 3):

S*	TA
SA*	TB
SB*	RK

Series no.:

10 = for direct current valves
11 = for alternate current valves
 (the overall and mounting dimensions remain unchanged from 10 to 19)

Seals:

N = NBR seals for mineral oil (**standard**)
V = FPM seals for special fluids

Option:
 Surface treatment non standard.
 Omit if not required (see **NOTE 2**)

Manual override (see par. 13) on **DC** version:
 omit for boot manual override integrated in the coil locking ring
CK1 = knob manual override
CPK = push manual override with mechanical retention
 on **AC** version:
 omit for manual override integrated in the tube
CM = manual override boot protected

Coil electrical connection: (see paragraph 11)
K1 = plug for connector type EN 175301-803 (ex DIN 43650) (**standard**)

For **D12** and **D24** coils only:
K2 = plug for connector type AMP JUNIOR
K4 = outgoing cables
WK7 = plug DEUTSCH DT04-2P for male connector type DEUTSCH DT06-2S
WK8 = plug for connector type AMP SUPER SEAL

DC power supply

D12 = 12 V	}	direct current
D24 = 24 V		
D28 = 28 V		
D48 = 48 V		
R110 = 110 V	}	rectified current
R230 = 230 V		
D00 = valve without coils (see NOTE 1)		
AC power supply		
A24 = 24 V - 50 Hz		
A110 = 110 V - 50 Hz		
A230 = 230 V - 50 Hz		
A00 = valve without coils (see NOTE 1)		

NOTE 1: Coils locking ring and related OR are supplied together with valves.

NOTE 2: The standard surface treatment is phosphating black. On request we can supply these valves with zinc-nickel finishing, making the valve suitable to ensure a salt spray resistance up to **600** hours (test operated according to UNI EN ISO 9227 standard and test evaluation operated according to UNI EN ISO 10289 standard)

Add **/W7** at the end of the identification code.

2 - HYDRAULIC FLUIDS

Use mineral oil-based hydraulic fluids HL or HM type, according to ISO 6743-4. For these fluids, use NBR seals (code N). For fluids HFDR type (phosphate esters) use FPM seals (code V). For the use of other fluid types such as HFA, HFB, HFC, please consult our technical department.

Using fluids at temperatures higher than 80 °C causes a faster degradation of the fluid and of the seals characteristics. The fluid must be preserved in its physical and chemical characteristics.

3 - SPOOL TYPE

Type S*:
2 solenoids - 3 positions
with spring centering

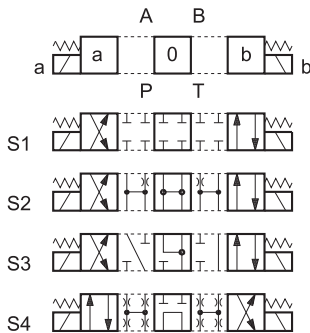

Type SA*:
1 solenoid side A
2 positions (central + external)
with spring centering

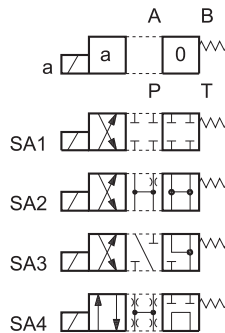

Type SB*:
1 solenoid side B
2 positions (central + external)
with spring centering

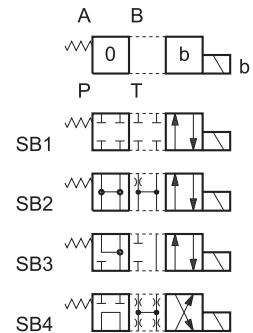

Type RK:
2 solenoids - 2 positions
with mechanical retention

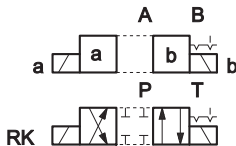

Type TA:
1 solenoid side A
2 external positions
with return spring

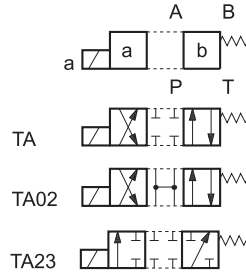

Type TB:
1 solenoid side B
2 external positions
with return spring

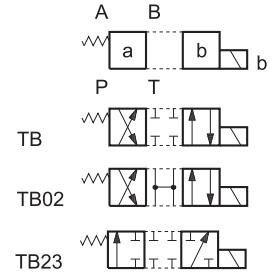

NOTE: Others spools available on request only.

4 - PRESSURE DROPS $\Delta P-Q$

(obtained with viscosity of 36 cSt at 50 °C)

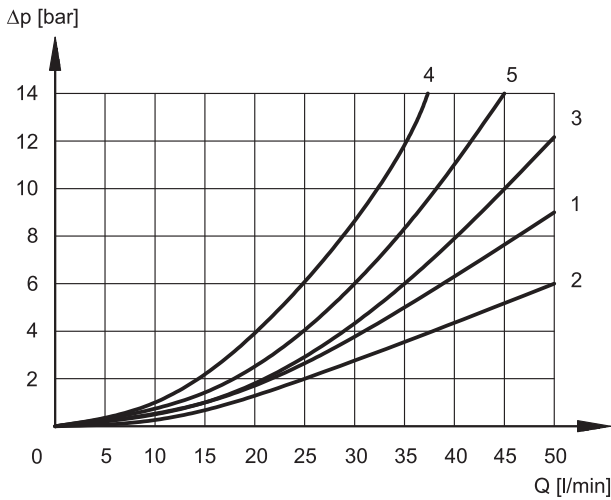

ENERGIZED VALVE

SPOOL	FLOW DIRECTIONS				
	P→A	P→B	A→T	B→T	P→T
	CURVES ON GRAPHS				
S1	1	1	1	1	-
S2	1	1	2	2	3
S3	3	3	2	2	-
S4	4	4	4	4	5
RK	1	1	1	1	-
TA	3	3	3	3	-

5 - OPERATING LIMITS

The curves define the flow rate operating fields according to the valve pressure of the different versions. The values indicated in the graphs are relevant to the standard solenoid valve.

The operating limits can be considerably reduced if a 4-way valve is used as 3-way valve with port A or B plugged or without flow.

The values have been obtained according to ISO 6403 norm with solenoids at rated temperature and supplied with voltage equal to 90% of the nominal voltage. The value have been obtained with mineral oil, viscosity 36 cSt, temperature 50 °C and filtration according to ISO 4406:1999 class 18/16/13.

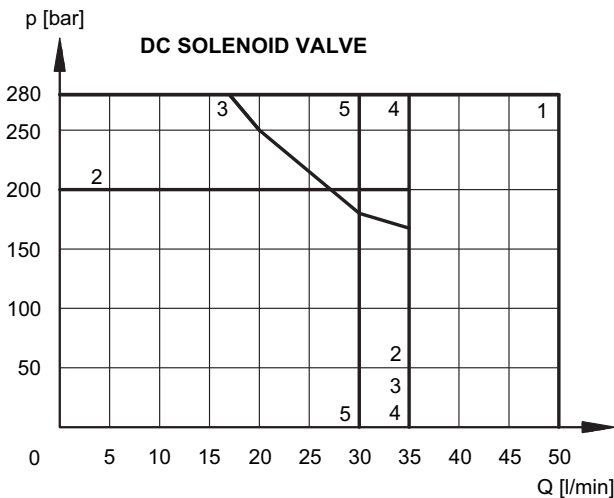

SPOOL	CURVE
S1, TA	1
S2	2
S3	3
S4	4
RK	5

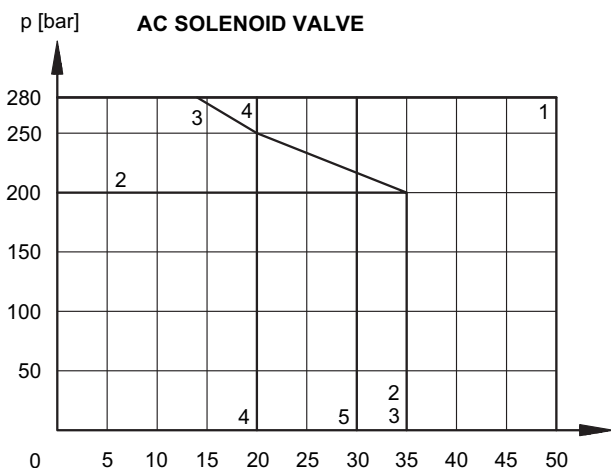

SPOOL	CURVE
S1, TA	1
S2	2
S3	3
S4	4
RK	5

6 - SWITCHING TIMES

The values indicated are obtained with spool S1, according to ISO 6403 standard, with mineral oil viscosity 36 cSt at 50°C.

SUPPLY	TIMES (±10%) [ms]	
	ENERGIZING	DE-ENERGIZING
DC	25 ÷ 75	15 ÷ 25
AC	10 ÷ 25	15 ÷ 30

7 - ELECTRICAL FEATURES

7.1 - Solenoids

These are essentially made up of two parts: tube and coil. The tube is threaded into the valve body and includes the armature that moves immersed in oil, without wear. The inner part, in contact with the oil in the return line, ensures heat dissipation.

The coil is fastened to the tube by a threaded ring, and can be rotated +/- 90°, to suit the available space.

The interchangeability of coils of different voltages is allowed within the same type of supply current, alternating or direct.

Protection from atmospheric agents IEC 60529

The IP protection degree is intended for the whole valve. It is guaranteed only with both valve and connectors of an equivalent IP grade, correctly connected and installed.

Electric connection	IP65	IP66	IP67	IP68	IP69 IP69K(*)
K1 EN 175301-803	x	x			
K2 AMP JUNIOR	x		x		
K4 outgoing cables	x				
WK7 DEUTSCH DT04 male	x		x	x	x
WK8 AMP SUPER SEAL	x	x	x	x	x

(*) The protection degree IP69K is not taken into account in IEC 60529 but it is included in both ISO 20653.

SUPPLY VOLTAGE FLUCTUATION	± 10% Vnom
MAX SWITCH ON FREQUENCY	10.000 ins/hr
DUTY CYCLE	100%
ELECTROMAGNETIC COMPATIBILITY (EMC)	In compliance with 2014/30/EU
LOW VOLTAGE	In compliance with 2014/35/EU
CLASS OF PROTECTION Coil insulation (VDE 0580) Impregnation	class H class H

NOTE: In order to further reduce the emissions, with DC supply, use of type H connectors is recommended. These prevent voltage peaks on opening of the coil supply electrical circuit (see cat. 49 000).

7.2 - DC valve - Current and power consumption

In direct current energizing, current consumption stays at fairly constant values, essentially determined by Ohm's law: $V = R \times I$

"R" coils have to be used when the valve is fed with AC power supply subsequently rectified by means of rectifier bridge, externally or incorporated in the "D" type connector (see cat. 49 000).

The table shows current and power consumption values for DC and RC coil types.

Coils for direct current (values ±5%)

	Nominal voltage [V]	Resistance at 20°C [Ω]	Current consumption [A]	Power consumption		Coil code				
				[W]	[VA]	K1	K2	K4	WK7	WK8
D12	12	5,4	2,2	26,5		1902740	1902750	1902770	1903510	1903520
D24	24	20,7	1,16	27,8		1902741	1902751	1902771	1903511	1903521
D28	28	27,5	1,02	28,5		1902744				
D48	48	82	0,58	28		1902745				
R110	110	363	0,25		27,2	1902742				
R230	230	1640	0,11		26,4	1902743				

7.3 - AC valve - Current and power consumption

In alternating current energizing, an initial phase (maximum movement) is seen, during which the solenoid consumes elevated value currents (inrush current); the current values diminish during the plunger stroke until it reaches the minimum values (holding current) when the plunger reaches the stroke end. The table shows the values of absorption at the inrush and at holding.

Coils for alternating current (values $\pm 10\%$)

	Nominal voltage [V]	Freq. [Hz]	Resistance at 20°C [Ω]	Current consumption at inrush [A]	Current consumption at holding [A]	Power consumption at inrush [VA]	Power consumption at holding [VA]	Coil code
A24	24	50	2,7	4,5	1,47	109,2	35,3	1903190
A110	110		73,4	1,0	0,31	107,8	34,1	1903192
A230	230		320	0,5	0,16	112,7	36,8	1903193

8 - DL3 DC OVERALL AND MOUNTING DIMENSIONS

dimensions in mm

DL3 - S*

DL3 - TA, DL3-SA*

solenoid position for execution type TB* - SB*

1	Mounting surface with sealing rings: 4 OR type 2037 (9.25x1.78) - 90 shore
2	Locking ring with boot protected manual override
3	Coil (90° revolving)
4	Coil removal space
5	EN 175301-803 (ex DIN 43650) electrical connector (representation with K1 standard connection - see paragraph 11 for other connection types)
6	Connector removal space

Valve fastening: 4 SHC screws ISO 4762 M5x30
Tightening torque: 5 Nm (A8.8)
Threads of mounting holes: M5x10

9 - DL3 AC OVERALL AND MOUNTING DIMENSIONS

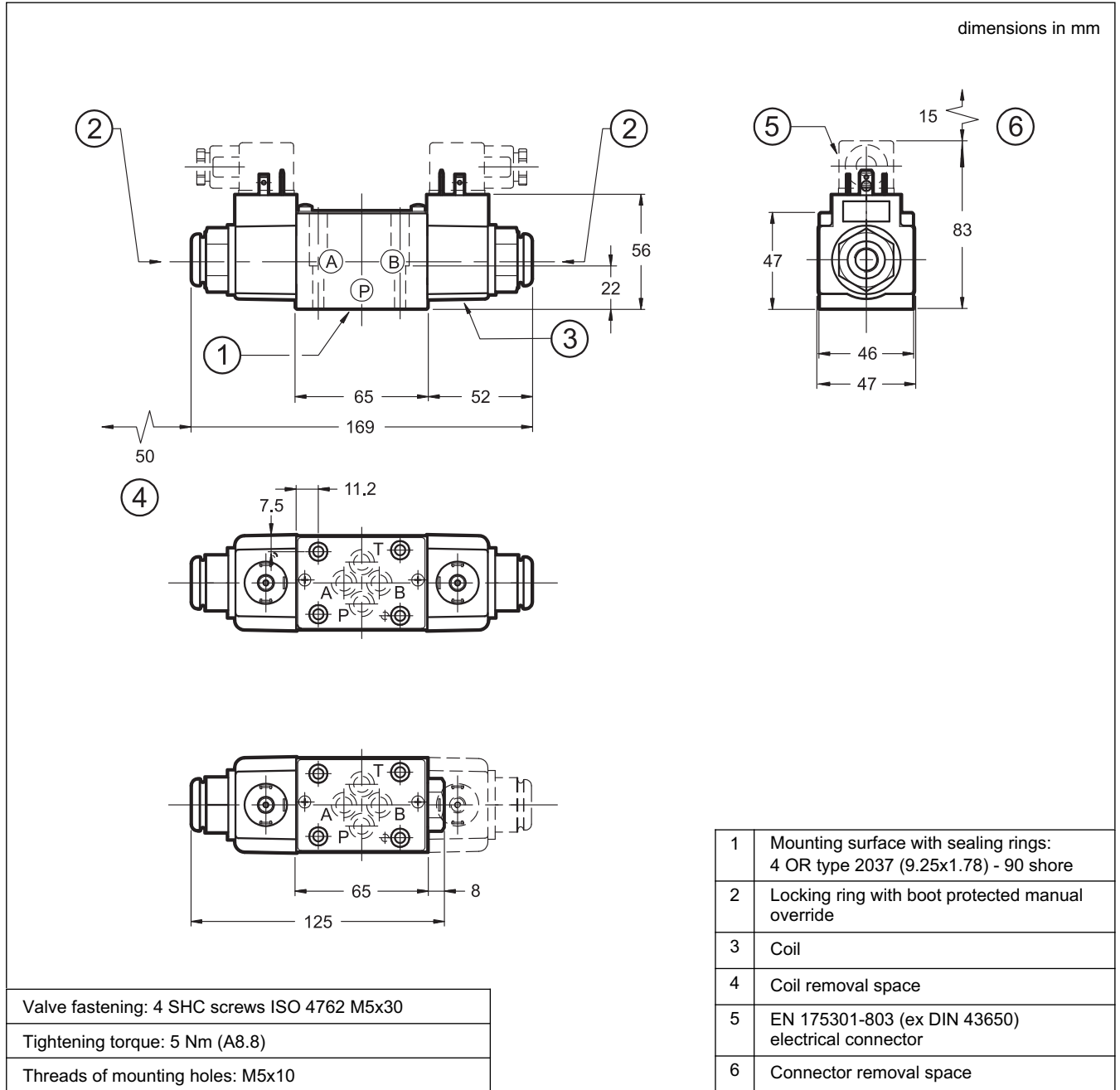

10 - INSTALLATION

Configurations with centering and return springs can be mounted in any position; type RK valves - without springs and with mechanical detent - must be mounted with the longitudinal axis horizontal.

Valve fitting takes place by means of screws or tie rods, fixing the valve on a lapped surface, with values of planarity and smoothness that are equal to or better than those indicated in the drawing.

If the minimum values of planarity or smoothness are not met, fluid leakages between valve and mounting surface can easily occur.

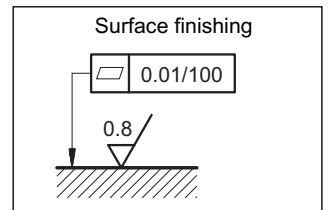

11 - ELECTRIC CONNECTIONS

connection for EN 175301-803
(ex DIN 43650) connector
code **K1 (standard)**

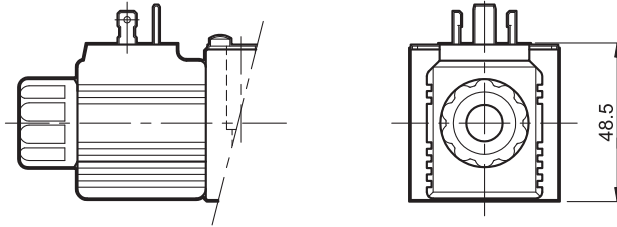

connection for AMP JUNIOR
connector type
code **K2**

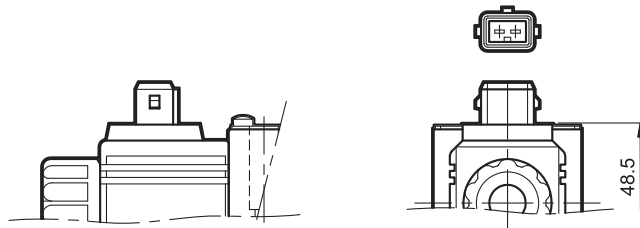

outgoing cable connections
cable length = 1 mt
code **K4**



connection for DEUTSCH DT04-2P
for male connector type DEUTSCH DT06
code **WK7**

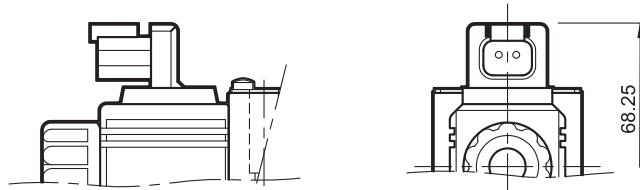

connection for AMP SUPER SEAL
(two contacts) connector type
code **WK8**

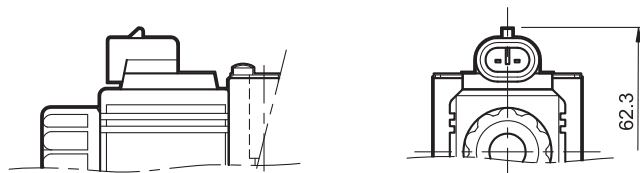

12 - ELECTRIC CONNECTORS

Solenoid operated valves are delivered without connectors. Connectors type EN 175301-803 (ex DIN 43650) for K1 connections can be ordered separately. See catalogue 49 000. We do not delivery connectors for connections K2, WK7 and WK8.

13 - OPTIONAL MANUAL OVERRIDES

13.1 - Boot protected manual override

On the DC version the boot override is integrated in the coil locking ring, as standard.

On the AC version, however, the boot override can be ordered by entering the code **CM** in the identification code at par. 1, or is available as option to be ordered separately.

code **3401210001**.

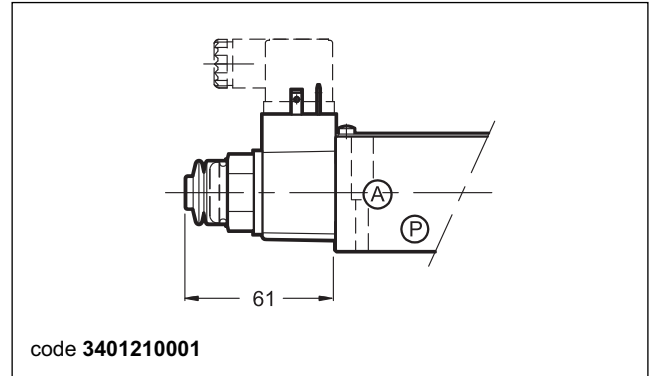

13.2 - Knob manual override

Available only for DC version

Max stroke: 4.5 mm

mm per turn: 1

The knob override can be ordered by entering the code **CK1** in the identification code at par. 1, or is available as option to be ordered separately.

code **3404100040**.

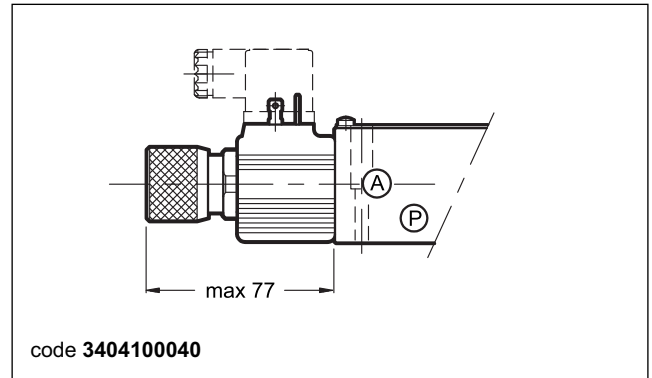

13.3 - Push manual override with mechanical retention

Available only for DC version

The push manual override with mechanical retention can be ordered by entering the code **CPK** in the identification code at par. 1, or is available as option to be ordered separately.

code **3401210003**.

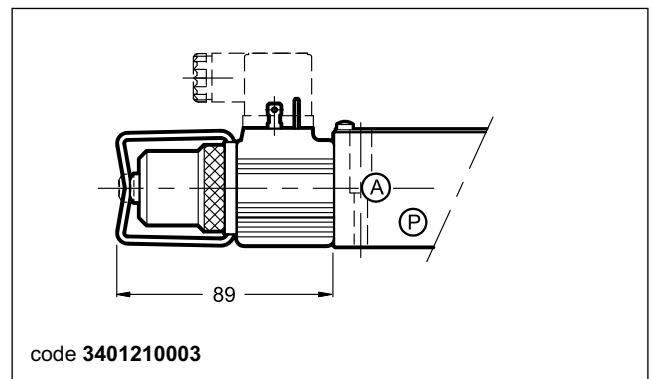

14 - SPARE PARTS FOR DC SOLENOID VALVE

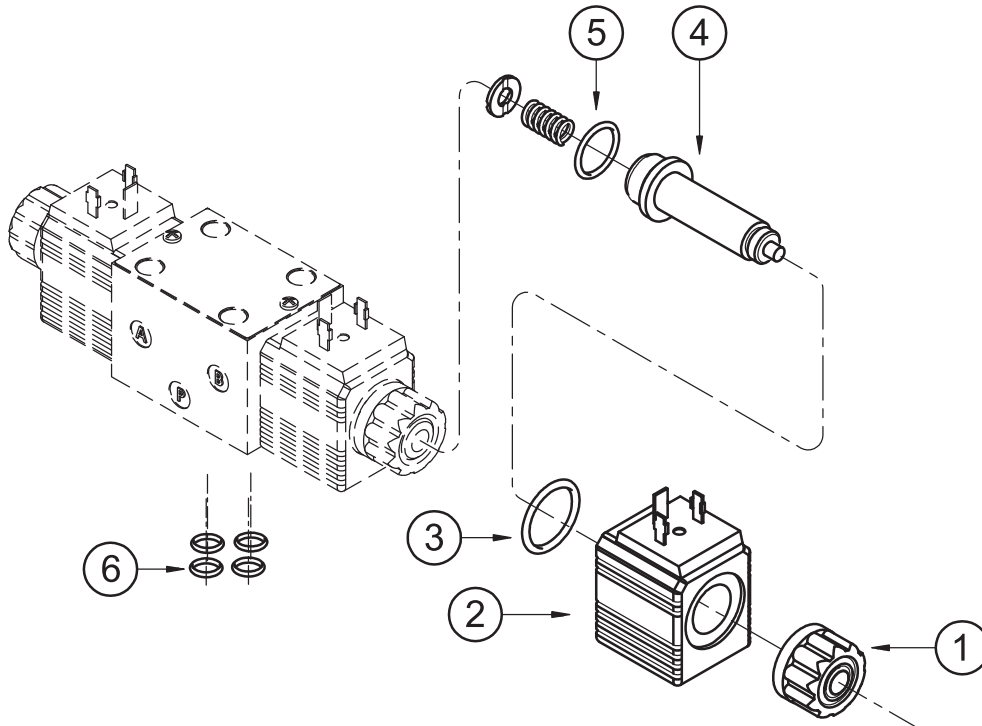

IDENTIFICATION CODE FOR DC AND RC COILS

C 14 L3 - / 10

Supply voltage _____
D12 = 12 V } direct
D24 = 24 V } current
D28 = 28 V }
D48 = 48 V }
R110 = 110 V } rectified
R230 = 230 V } current

Series no.:
 (the overall and mounting dimensions remain unchanged from 10 to 19)

Coil electrical connection:
K1 = plug for connector type EN 175301-803 (ex DIN 43650)

D12 and **D24** coils only:
K2 = plug for connector type AMP JUNIOR
K4 = outgoing cables

WK7 = plug DEUTSCH DT04-2P for male connector type DEUTSCH DT06-2S

WK8 = plug for connector type AMP SUPER SEAL

1	Coil locking ring - code 0119382 tightening torque: 3 + 3.4 Nm
2	Coil (see identification code)
3	OR type 2112 (28.3x1.78)
4	Solenoid tube: TD14-M18/11N (NBR seals) TD14-M18/11V (FPM seals) (OR n° 5 included)
5	OR type 2062 (15.6x1.78) - 70 Shore
6	N. 4 OR type 2037 (9.25x1.78) - 90 Shore

SEAL KIT

The codes included the OR n° 5 and 6.
Cod. 1984435 NBR seals
Cod. 1984436 FPM seals

15 - SPARE PARTS FOR AC SOLENOID VALVE

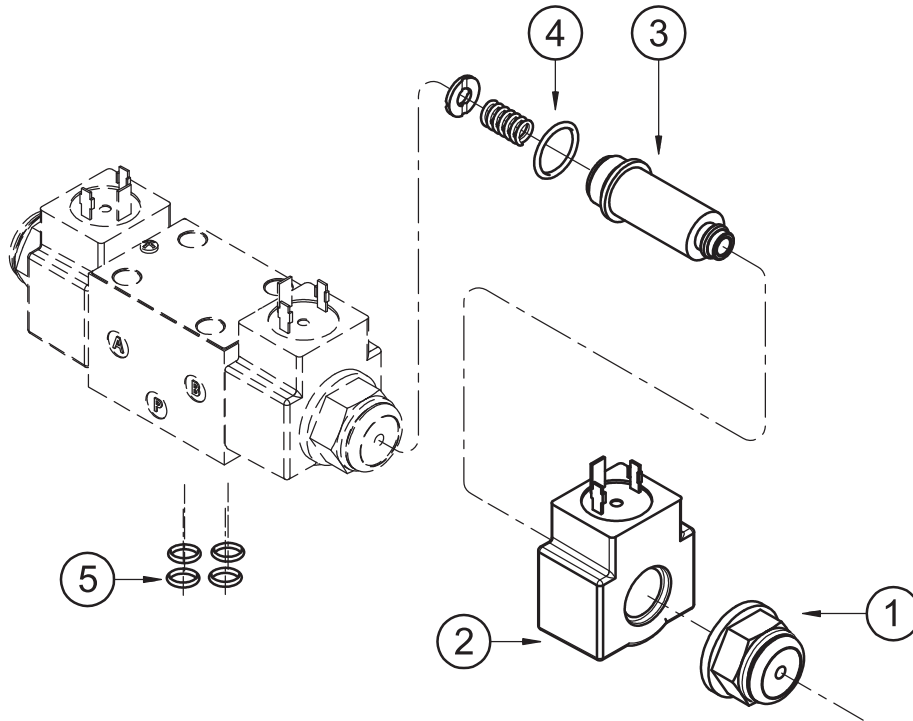

IDENTIFICATION CODE FOR AC COILS

C 18 L3 - K1 / 11

Supply voltage _____
A24 = 24 V - 50 Hz
A110 = 110 V - 50 Hz
A230 = 230 V - 50 Hz

Series no.:
 (the overall and
 mounting dimensions
 remain unchanged from
 10 to 19)

Coil electrical connection:
 plug for connector type
 EN 175301-803 (ex DIN 43650)

1	Coil locking ring - code. 0119469 tightening torque: 3 + 3.4 Nm
2	Coil (see identification code)
3	Solenoid tube: TA18-M18/11N (NBR seals) TA18-M18/11V (FPM seals) NOTE: OR n° 4 included.
4	OR type 2062 (15.6x1.78) - 70 Shore
5	N. 4 OR type 2037 (9.25x1.78) - 90 Shore

SEAL KIT

The codes included the OR n° 4 and 5.
Cod. 1984435 NBR seals
Cod. 1984436 FPM seals

16 - SUBPLATES

(see catalogue 51 000)

Type PMMD-AI3G with rear ports
Type PMMD-AL3G with side ports
P, T, A, B port threading: 3/8" BSP

**DIPLOMATIC MS S.p.A.**

via M. Re Depaolini 24 • 20015 PARABIAGO (MI) • ITALY
tel. +39 0331.895.111
www.diplomatic.com • e-mail: sales.exp@diplomatic.com